

# **AT** MICROFICHE REFERENCE LIBRARY

A project of Volunteers in Asia

Overshot and Current Water Wheels  
Bulletin 398

by: O.W. Monson and Armin J. Hill

Published by:

Montana Agricultural Experiment Station  
Montana State University  
Bozeman, MT 59717 USA

Single copies are free.

Available from:

Montana Agricultural Experiment Station  
Montana State University  
Bozeman, MT 59717 USA

Reproduced by permission of the Montana  
Agricultural Experiment Station, Montana State  
University.

Reproduction of this microfiche document in any  
form is subject to the same restrictions as those  
of the original document.

Bulletin 398  
Reprint

Sept. 1975

# OVERSHOT AND CURRENT WATER WHEELS

Design, Construction and Installation for Small Power  
Developments on Ranch and Farm

BY

O. W. Morrison and Armin J. Hill

DEPARTMENT OF IRRIGATION AND DRAINAGE



Montana Agricultural Experiment Station  
Montana State University, Bozeman

## TABLE OF CONTENTS

	Page
INTRODUCTION .....	3
OVERSHOT WATER WHEELS, Design, Construction and Installation.....	4
1. DETERMINING MAJOR DESIGN SPECIFICATIONS AND DIMENSIONS .....	4
(a) General Wheel Design .....	4
(b) Wheel Dimensions .....	6
2. SELECTION OF MATERIALS AND DETERMINATION OF MINOR DESIGN FEATURES .....	7
(a) Axles .....	8
(b) Hubs .....	8
(c) Radial Arms (Spokes) .....	10
(d) Bracing .....	10
(e) Soling .....	12
(f) Bucket Ends or Shrouding .....	12
(g) Buckets .....	13
(h) Checking Final Design Details .....	15
3. LAYING OUT THE WHEEL AND CUTTING PARTS TO PROPER DIMENSIONS..	15
4. CONSTRUCTING WHEEL MOUNTINGS AND TAIL RACE .....	16
(a) Wheel Mountings .....	16
(b) Bearings .....	16
(c) The Tail Race .....	16
5. MOUNTING THE AXLE ASSEMBLY AND ASSEMBLING THE WHEEL.....	17
(a) The Axle Assembly .....	17
(b) Assembling the Wheel .....	17
6. BALANCING THE WHEEL .....	17
7. DELIVERY OF WATER TO THE WHEEL .....	18
8. THE POWER DRIVE .....	19
9. SHELTER FOR THE WHEEL .....	20
CURRENT WATER WHEELS, Design, Construction and Installation .....	21
1. DETERMINATION OF MAJOR DESIGN FEATURES AND SPECIFICATIONS .....	23
2. SELECTION OF MATERIALS AND DETERMINATION OF MINOR DESIGN FEATURES .....	25
(a) Paddles .....	25
3. LAYING OUT THE WHEEL AND CUTTING PARTS TO PROPER DIMENSIONS..	25
4. CONSTRUCTION OF WHEEL MOUNTINGS, APPROACH FLUMES, TAIL RACE, ETC. ....	26
(a) Mounting .....	26
(b) Use of an Approach Flume .....	26
(c) A Tight Fitting Chute under the Wheel .....	28
(d) The Tail Race .....	28
(e) Water Control .....	28
5-6. MOUNTING THE AXLES ASSEMBLY. ASSEMBLING AND BALANCING THE WHEEL .....	28
7. POWER DRIVES FOR CURRENT WHEELS .....	28
APPENDIX I. HOW TO LAY OFF ANGLES WITH A STEEL SQUARE....	30
TABLE 1. COMPARATIVE SHAFT DIMENSIONS TO GIVE EQUAL STRENGTHS IN TWISTING (SHEAR) .....	8
TABLE 2. DISTANCES FOR LAYING OFF ANGLES WITH A STEEL SQUARE .....	30

# OVERSHOT AND CURRENT WATER WHEELS

## Design, Construction and Installation for Small Power Developments on Ranch and Farm

By

O. W. MONSON and ARMIN J. HILL

---

### INTRODUCTION

This publication is based upon field studies by this department of existing water wheel installations in Montana, and upon studies of water wheels conducted in the laboratories of the Experiment Station. Upon these studies are also based the general directions outlined for laying out, assembling, and mounting water wheels, and for arranging suitable power drives. These directions are intended to serve as a guide in the construction of a small water power plant which will be free of most of the defects found in existing plants, and also to indicate the manner in which local materials and labor can be used in an economical manner in the construction of these plants.

Detailed specifications and dimensions will differ with each installation, and must be calculated to meet the requirements of each specific case. If sufficient data is furnished to the Irrigation Department of the Experiment Station, design specifications will be supplied to fit the particular problem.

---

**ACKNOWLEDGMENT:** The authors wish to acknowledge the valuable work of Professor H. E. Murdock of the Agricultural Engineering Department of Montana State College, who carried on much of the early study on this project.

## OVERSHOT WATER WHEELS

### DESIGN, CONSTRUCTION AND INSTALLATION\*

The design, construction, and installation of an overshot water wheel should be made in the following general order:

1. Determine major design dimensions and specifications for the wheel.
2. Select the materials, and decide on minor features of design and arrangement.
3. Lay out the wheel and cut parts to proper dimensions.
4. Construct wheel mountings and tail race.
5. Mount axle assembly and assemble the wheel.
6. Balance the wheel.
7. Construct delivery chute and water controls for proper delivery of water to the wheel.
8. Assemble the power drive.
9. Provide a suitable shelter for the wheel.

#### 1. DETERMINING MAJOR DESIGN SPECIFICATIONS AND DIMENSIONS

Homemade construction need not be makeshift. First class construction may cost a little more in materials and labor, but the difference is usually small when compared with the total cost of the installation; and the extra investment will be fully repaid in long-time satisfaction. This added investment may very possibly mean the difference between a successful and an unsuccessful water power development.

(A) **GENERAL WHEEL DESIGN.**—Overshot wheels can be built entirely of metal, of both wood and metal, or almost entirely of wood, depending upon the kinds of material, tools, and craftsmanship available. All-metal wheels are made with heavy sheet metal forming the soling, buckets, and shrouding, with angle or channel iron for radial arms and braces, and with iron castings or steel plates used for the hubs. A great deal of skill is required in their assembly, and the best results are obtained when the seams are welded instead of riveted. For these reasons it is best to have available the facilities of a good metal-working shop if this type of construction is to be considered.

\*For suggestions on planning a farm water power plant, constructing the necessary dams, water approaches, and controls, and for doing other work preliminary to the actual construction and installation of a water wheel, consult Extension Bulletin No. 197, "Water Power on the Farm." This may be obtained from any county extension agent, or from the Montana Extension Service, Bozeman, Montana.

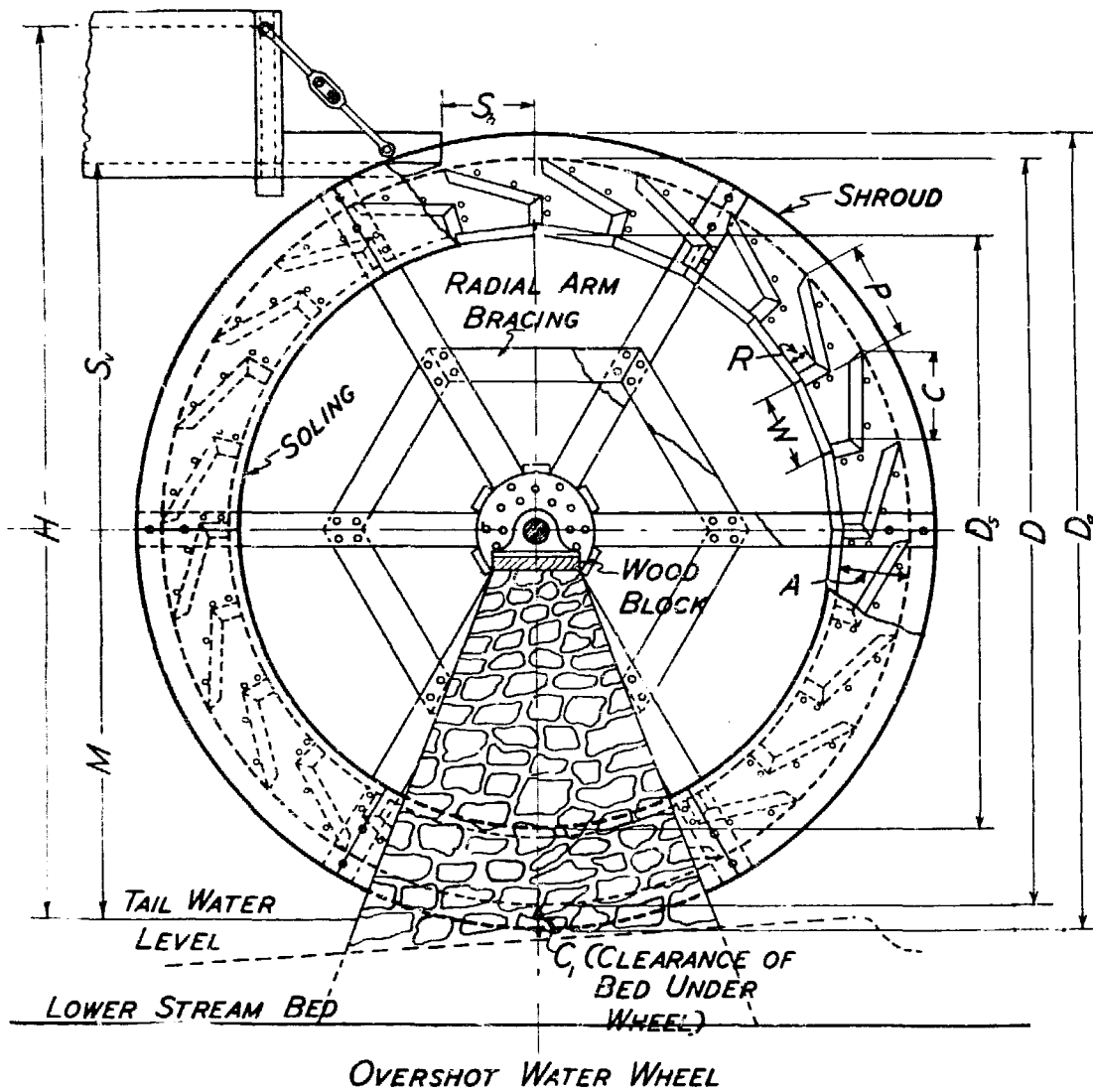

FIG. 1. CONSTRUCTION AND MOUNTING OF AN OVERSHOT WHEEL (WOODEN CONSTRUCTION).

- |  |  |
|--|--|
| <b>H</b> — Head  | <b>M</b> — Mounting height   |
| <b>S<sub>v</sub></b> — Vertical distance of spout above center line of wheel             | <b>A</b> — Radial depth of buckets   |
| <b>S<sub>h</sub></b> — Horizontal distance to tip of spout ahead of center line of wheel | <b>R</b> — Width of inner radial board   |
| <b>D</b> — Nominal diameter of wheel measured to bucket edges                            | <b>P</b> — Pitch of edge of outer board ahead of radial line through back of bucket                |
| <b>D<sub>s</sub></b> — Diameter of soling, measured outside and across corners           | <b>C</b> — Width of outer board  |
| <b>D<sub>a</sub></b> — Diameter of outer edge of shrouding                               | <b>W</b> — Width of soling plank   |
|  | <b>C<sub>1</sub></b> — Clearance under bottom of wheel, measured to bottom of stream bed or to pan |

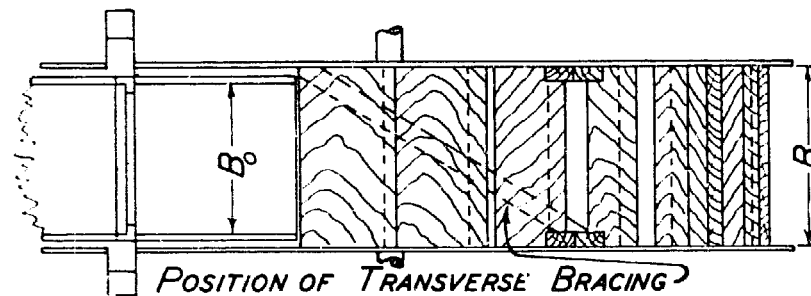

FIG. 1A. PLAN VIEW OF AN OVERSHOT WHEEL.

**B** — Width of wheel (inside)      **Bo** — Width of spout

Numerical values of these dimensions will be available through the Agricultural Experiment Station, upon receipt of sufficient data from which to design wheel.

Either all-wood or a combination of wood and metal construction is more commonly used when good lumber and timber are available. The all-wood type has the advantage that practically all of the work of cutting and assembling can be done "on location," and only common woodworking tools are needed. Finished lumber is required for the buckets and shrouding, carefully fitted planks are used for the soling, and either rough or finished timbers are satisfactory for radial arms and bracing. It has been found that metal castings or plates are much better than wood for hubs, and any overshot wheel should be mounted on a good quality, heavy, steel shaft, which is carefully mounted in good metal bearings.

Metal buckets give a higher efficiency than do wooden buckets. Therefore, wheels are often constructed with wooden radial arms, bracing, and soling, but with metal buckets, and sometimes with metal shrouding also. This combination type of construction has most of the advantages of the all-metal wheel, and is therefore recommended where all-metal construction is not practical.

(B) WHEEL DIMENSIONS.—The most important dimensions for the wheel mounting, water approach, and tail race, are shown in figure 1. Also included in this figure are the most important dimensions for an all-wood wheel. Similar dimensions for an all-metal wheel are shown in figure 2. Details of wheel construction for all-wood, wood-metal, and all-metal wheels are shown in figures 3 to 7. Some additional dimensions are indicated in these figures. Values of these dimensions can be supplied through the Agricultural Experiment Station, provided sufficient data is submitted.

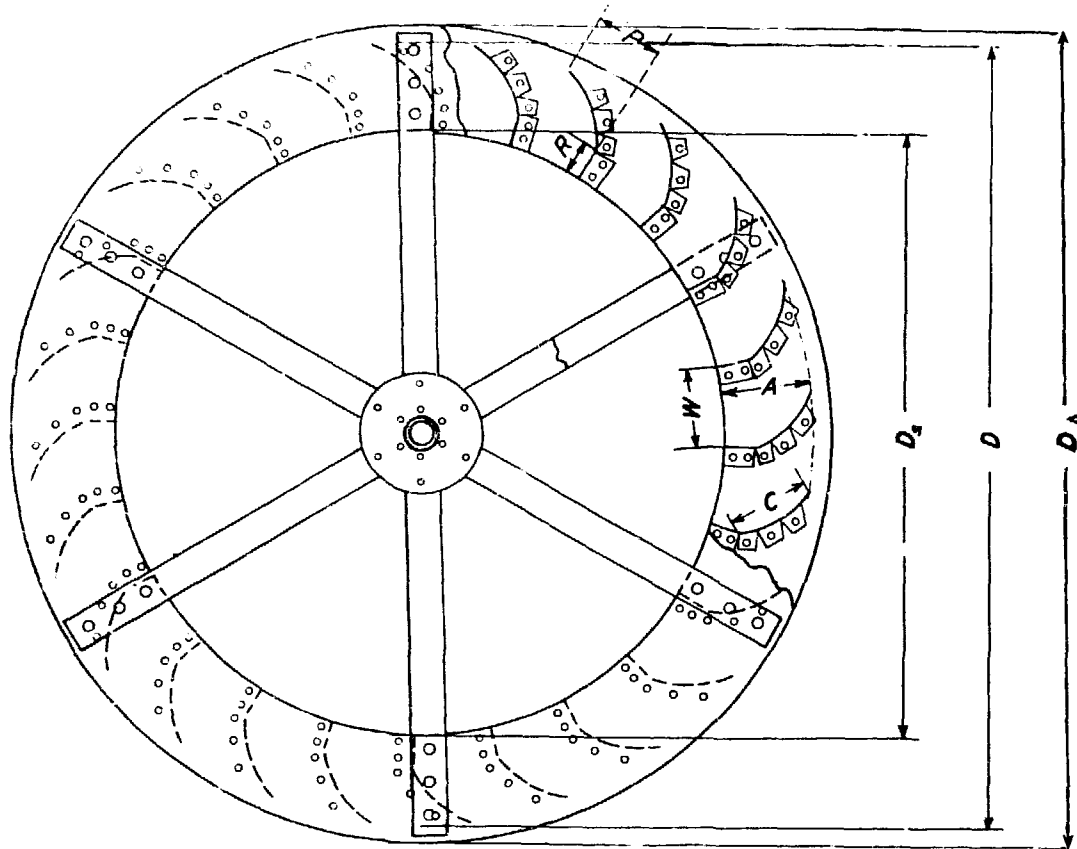

### ALL METAL WHEEL

FIG. 2. CONSTRUCTION OF ALL-METAL OVERSHOT WHEEL.

- |   |   |
|---|---|
| <b>D</b> — Nominal diameter   | <b>A</b> — Radial depth of buckets                        |
| <b>Da</b> — Diameter of outer edge of shrouding                             | <b>R</b> — Distance bucket curve extends radially         |
| <b>P</b> — Pitch of bucket edge ahead of radial line through back of bucket | <b>C</b> — Length of chord of bucket arc                  |
| <b>D<sub>s</sub></b> — Diameter of soling                                   | <b>W</b> — Distance between buckets measured along soling |

## 2. SELECTION OF MATERIALS AND DETERMINATION OF MINOR DESIGN FEATURES

Discarded farm machinery may supply valuable materials for water wheel construction. All materials should be in good condition and substantial enough to last a long time. Each part must be strong enough to withstand the most severe conditions which will be imposed upon it, and do this year after year. A broken or bent bucket can be replaced quite easily, but a broken or weak radial arm may result in serious damage to the entire wheel. The most important parts, therefore, must be given extra strength or a larger factor of safety. Against this necessity of strength must be considered the additional weight and cost due to the larger parts. Careful judgment must be exercised if all parts are to be



strong enough, but not too large. Judicious use of metal bracing and reinforcement is one of the best ways to add strength without unduly increasing the weight or cost of the wheel, and should therefore be considered in the wheel design.

(A) AXLES.—Farm machinery axles will serve very well for water wheels, and generally these can be used in their original bearings. For example, a mowing machine axle with its bearings makes an excellent mounting for water wheels  $3\frac{1}{2}$  to 4 feet in width. Discarded line shafts work very well for wider wheels. These axles must bear the weight of the wheel, that of the water as it passes over, and must also transmit the power from one end of the wheel to the other. For these reasons it is better to have them too large than too small. Suggested minimum dimensions will be given with other important design data for each individual wheel.

(B) HUBS.—Since the shaft turns with the wheel, almost any arrangement which will hold the radial arms securely can be used

TABLE 1. COMPARATIVE SHAFT DIAMETERS TO GIVE EQUAL STRENGTHS IN TWISTING (SHEAR)

Solid Steel Shaft	Steel Shaft with Keyway	Steel Shaft with Drilled Hole	Square or Round Timber Shaft
1	1 3/16	1 5/16	3 1/2
1 1/8	1 1/4	1 7/16	4
1 1/4	1 7/16	1 5/8	4 1/2
1 3/8	1 9/16	1 3/4	5
1 1/2	1 11/16	1 15/16	5 1/2
1 5/8	1 7/8	2 1/16	6
1 3/4	1 15/16	2 1/4	6 1/2
1 7/8	2 1/8	2 3/8	7
2	2 1/4	2 5/8	7 1/2
2 1/8	2 3/8	2 11/16	8
2 1/4	2 1/2	2 7/8	8 1/2
2 3/8	2 5/8	3	8 1/2
2 1/2	2 3/4	3 3/16	9
2 5/8	2 15/16	3 5/16	9 1/2
2 3/4	3 1/16	3 1/2	10
2 7/8	3 3/16	3 5/8	
3	3 5/16	3 13/16	
3 1/8	3 7/16	3 15/16	
3 1/4	3 5/8	4 1/8	
3 3/8	3 3/4	4 1/4	
3 1/2	3 7/8	4 3/8	
3 5/8	4	4 5/8	
3 3/4	4 1/8	4 3/4	
3 7/8	4 5/16	4 15/16	
4	4 7/16		
4 1/4	4 11/16		
4 1/2	5		
4 3/4	5 1/4		

Note: Measurements are given in inches.

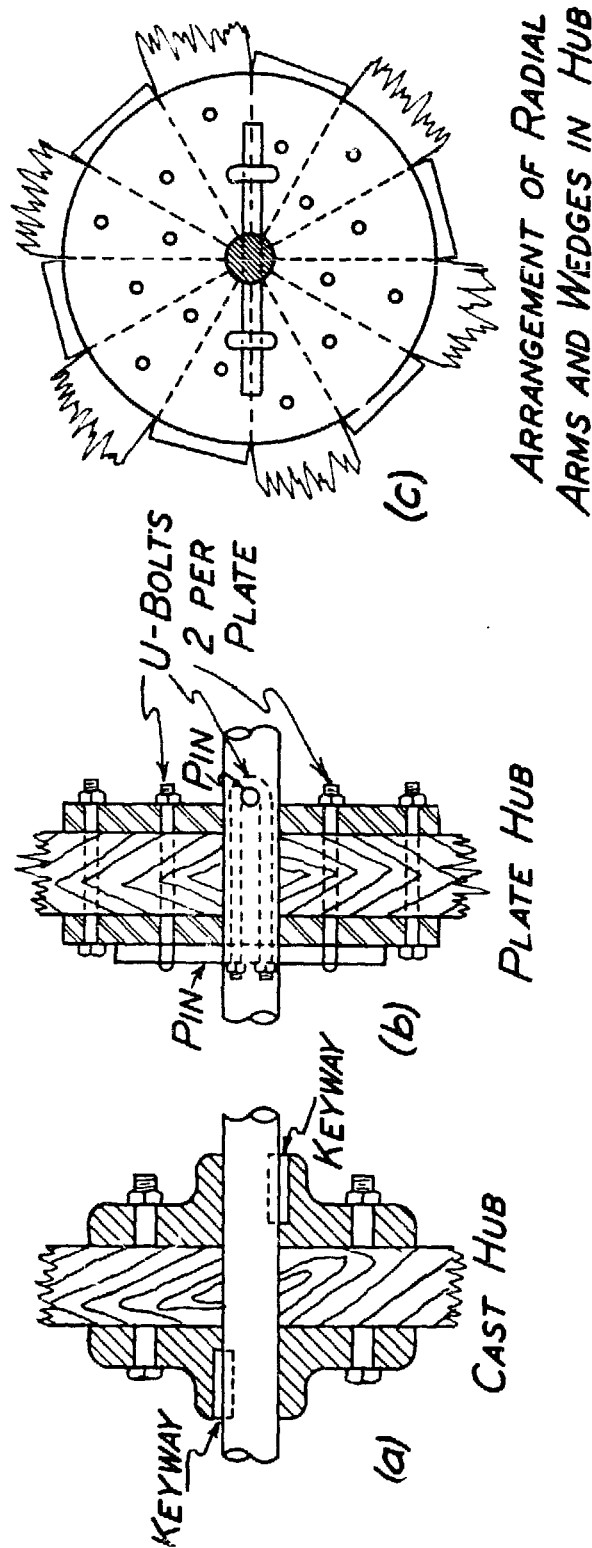

HUB DETAILS FOR WOOD WHEELS

FIG. 3. HUB DETAILS FOR WOODEN WHEELS.

as a hub. Suitable parts usually can be found on old farm machinery. If cast hubs are not available, two steel plates can be arranged to work satisfactorily as shown in figure 3-b. Hubs can be fastened to axles by keying, welding or pinning; but when a hole is drilled

through a shaft, it will be weakened and a larger shaft is then necessary for a given strength. The size necessary for comparable strength of solid shafts, whether made with keyway or with hole drilled for pin, is given in table 1. Only the finest quality materials should be used for shafts, hubs, keys, pins, etc., for these are the foundation of the wheel, and failure of any one will result in serious damage. The metal parts should also be well protected from rusting by means of paint, a grease film, or similar means.

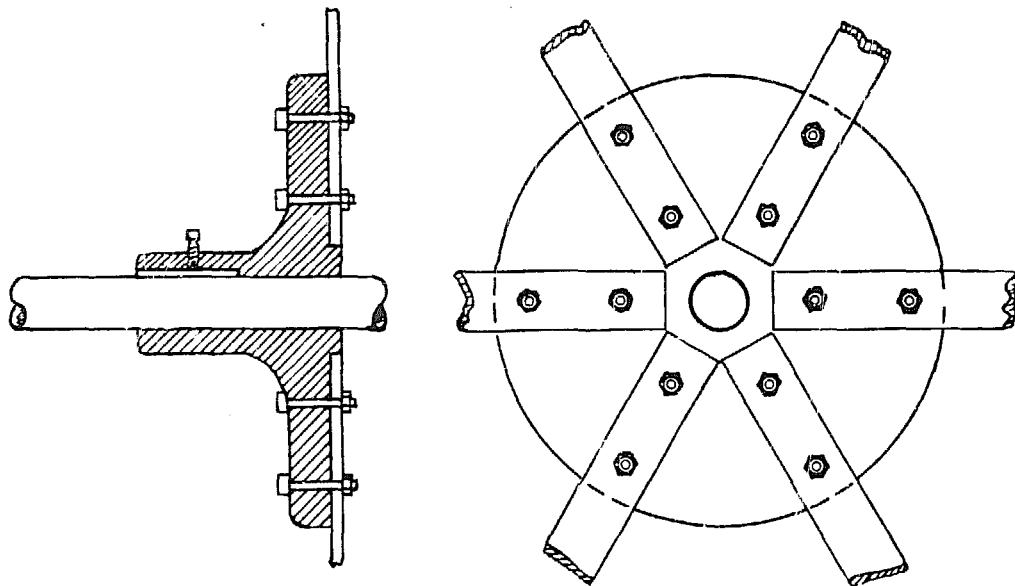

*HUB DETAILS*  
*METAL WHEELS*

FIG. 4. HUB DETAILS FOR METAL WHEELS.

(C) RADIAL ARMS (SPOKES).—The radial arms hold the buckets and transmit power from them to the axle. They should always be of good material, carefully selected, and strong enough to withstand any strain which may be placed upon them. These arms should be well painted with a heavy, waterproof paint to prevent rusting if the arms are of metal, and to prevent waterlogging if of wood.

(D) BRACING.—Careful bracing will materially add to the strength of a wheel without greatly increasing its weight or cost. The amount and direction of this bracing will depend upon the diameter, width, and power output of the wheel, and will therefore differ in wheels of different dimensions and power outputs. Very small wheels may need no bracing, while metal wheels will generally require less than wooden wheels. The bracing should be placed so that it will prevent sidesway, and should also help

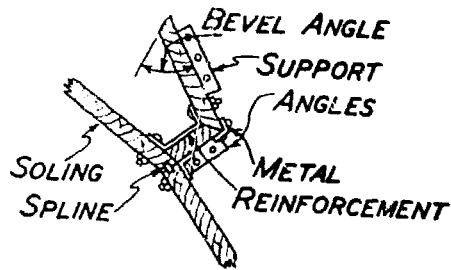

(a) *DETAIL OF BUCKET CONSTRUCTION & MOUNTING*

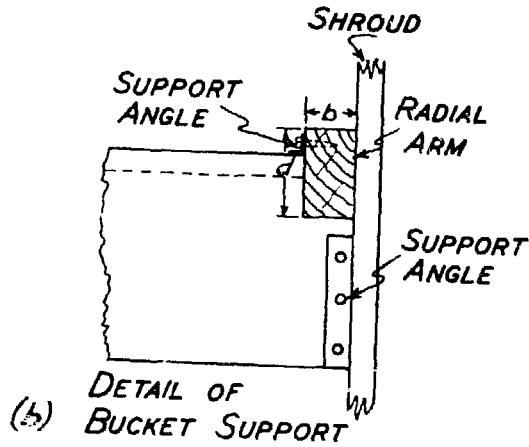

(b) *DETAIL OF BUCKET SUPPORT*

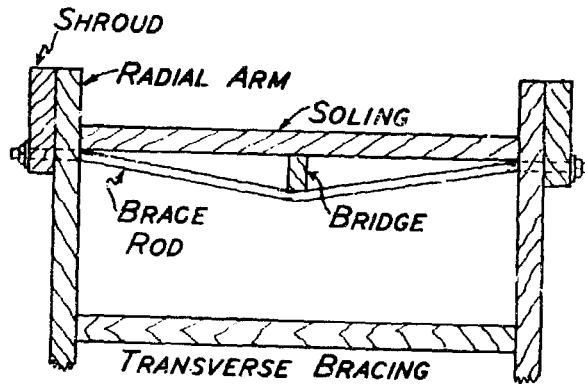

*DETAIL OF BRACING FOR WIDE WHEELS  
(c) (BUCKETS NOT SHOWN)*

FIG. 5. CONSTRUCTION DETAILS FOR WOODEN WHEELS.

transmit power from one end of the wheel to the other. For narrow wheels of large diameter, the bracing may take the form of a lattice work between corresponding spokes on opposite sides of the wheel. For wider wheels a transverse bracing, in a plane parallel to the axle, is often used. Such bracing is skewed so that the end nearest the driving pulley or gear is ahead of the outer end, as shown in figure 1-b.

For wide wheels, additional strength can be given the inner rims of the wheel, or the soling, by means of a bridge made of a steel rod placed under each soling plank as shown in figure 5-c. Very wide wheels should have additional hubs and sets of radial arms so that the soling is supported every five or six feet along the wheel width.

Proper bracing and reinforcement, with accurate cutting and fitting of all parts, should make the finished wheel rigid in all directions. This is very necessary if failure is to be avoided.

(E) SOLING.—The soling is the cylindrical inner rim of the wheel, which forms the back of the buckets, and also helps support the buckets (see figure 1-a). If made of metal, it should be thick enough that it will not be punctured by sharp rocks or other objects, and strong enough that it will readily transmit the bucket pressure to the radial arms. If of wood, it should be made watertight. Each soling plank is the back of one bucket, and thus should preferably be a single piece. Connections between planks are rigidly held together by the bucket supports, but additional precautions such as the use of splines, caulking, or additional reinforcement of the joints will further insure against any danger of water leakage at these joints. All bolt holes through the soling must be made watertight, and bolts should be well painted or otherwise protected against rust.

(F) BUCKET ENDS OR SHROUDING.—The ends of the buckets consist of circular shaped pieces of either wood or metal, corresponding to the fellies of a wagon wheel. When these extend beyond the bucket edges for a distance of from 2 to 4 inches they are called "shrouds." These prevent splashing and loss of water from the ends of the buckets, will confine the overflow of the buckets to the wheel, and will add to its efficiency under flood conditions. Shrouds, therefore, increase the maximum power output of a wheel; help it to operate more satisfactorily under an abnormal load, or an excessive water supply; and protect the wheel against freezing around the edges during cold weather.

Shrouds can be of wood or of metal, but should be strong enough not to be damaged by debris coming over the wheel. They can wade a little in the tail water without causing trouble, but if possible this should be avoided.

With wooden construction, the radial arms are usually brought inside the shrouding, as a tight fit with the soling is not difficult and there is plenty of room at the bucket ends to provide for escape of air as the bucket fills with water. It is harder to seal a metal soling, however. When such is used, radial arms usually come outside of the shrouding, and soling and shrouding are sealed together as shown in figure 6-d.

(G) BUCKETS.—The buckets cut the stream of water, catch it, and turn the energy which it contains into mechanical motion. The water should enter them without splashing, and remain in them until it gets as near the bottom of the wheel as possible. The shape of the buckets therefore is very important, and they must be formed with great care. Often metal tanks or barrels have been cut to form buckets, but this is not recommended unless these can be made to conform very closely to the required bucket shape. A slight deviation will decrease the efficiency of the wheel.

Since wooden buckets are not easily constructed in a curved pattern, they are generally made of two pieces as shown in figure 1 and figure 5-a. To prevent splashing, the edge of the bucket is beveled as shown, and the angle of this bevel is carefully determined so that the bucket edge cuts the stream smoothly. The shape of the bucket is determined by the radial depth "A", the width of the radial board "R" (measured to the inner edge as shown in figure 1-a), and the pitch of the tip of the outer board ahead of the radial line through the back of the radial board. Since this tip also falls on the wheel circumference, these dimensions determine the bucket shape.

Air must escape as water enters the buckets. For narrow wheels all of this escape takes place at the ends, and buckets must therefore be made wider than the stream. For wide wheels the buckets should be ventilated by a hole every foot, or foot and one-half, along the bottom of the bucket, as shown in figure 2 and figure 6, to allow the air to escape without loss of water. These holes should be from one-half to five-eighths of an inch in diameter. Note that they are in the *bucket*, not in the *soling*.

On wooden buckets the outer board should be securely fastened to the inner radial board at several points by means of light strap iron pieces. The joint between these two boards need not be absolutely watertight. The radial board should be firmly anchored to the soling, and both boards should be well supported from the shrouding and directly fastened to the radial arms wherever possible. Supports for wooden buckets can be made of light angle iron. Wheels with buckets shaped as recommended will be found to slap the water a little on entering the stream, but this is caused by the sharp pitch given the buckets, which in turn makes it possible to hold the water lower down on the wheel. The loss of

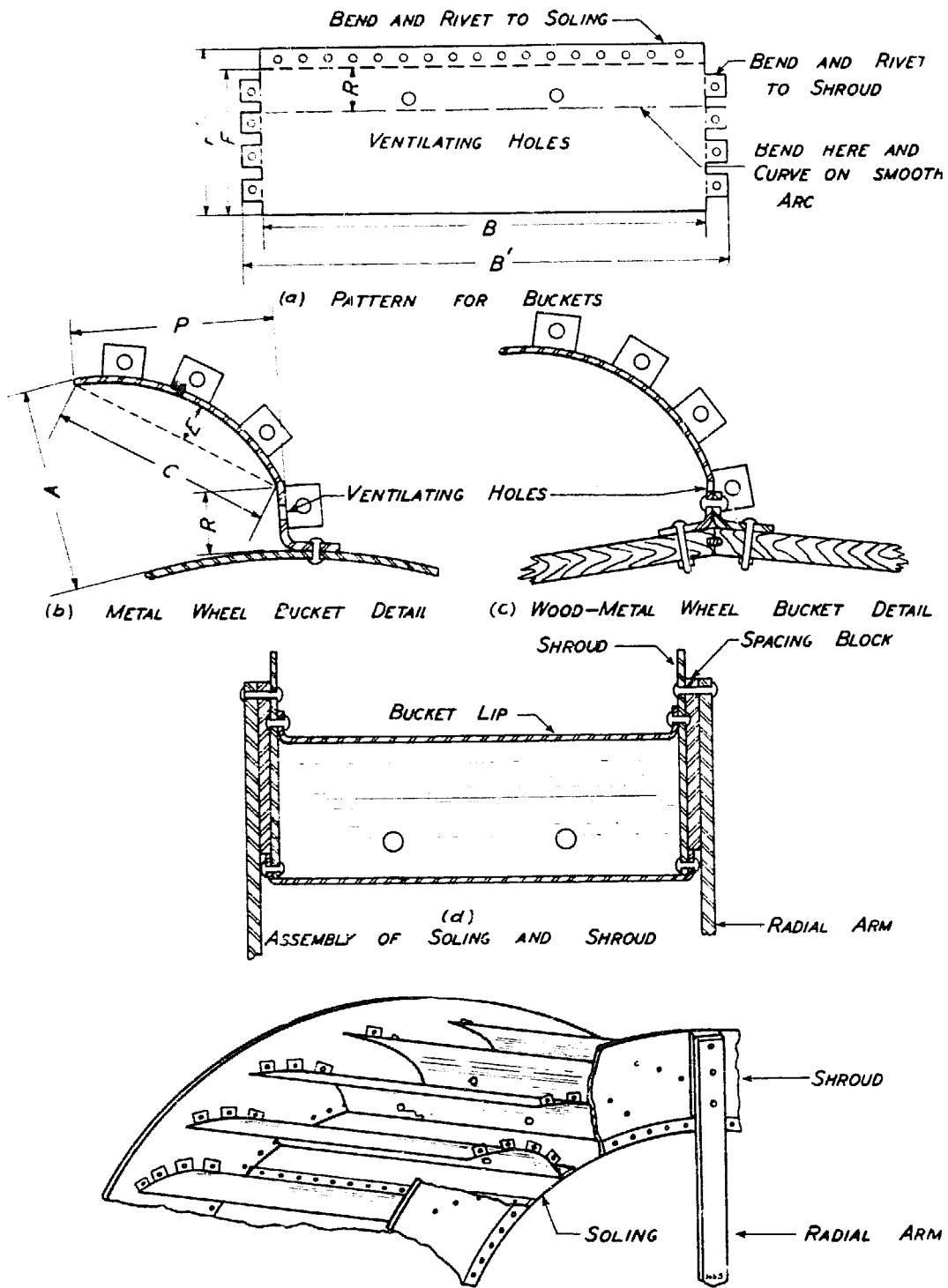

(e) CUT-AWAY SECTION OF METAL WHEEL ASSEMBLY

FIG. 6. CONSTRUCTION DETAILS FOR METAL AND WOOD-METAL WHEELS.

- |   |  |
|---|--|
| <b>B</b> — Width of wheel (inside)  | <b>B'</b> — Length of sheet metal to form bucket |
| <b>F'</b> — Width of sheet metal to form bucket                             | <b>F</b> — Width of metal forming bucket curve   |
| <b>R</b> — Distance bucket extends radially                                 | <b>A</b> — Radial depth of bucket                |
| <b>P</b> — Pitch of bucket edge ahead of radial line through back of bucket | <b>C</b> — Length of chord of bucket arc         |
|   | <b>E</b> — Depth of bucket arc                   |

efficiency caused by the slap is more than offset by the increased power from carrying the water farther down. The wheel will thus operate satisfactorily at the recommended speeds.

Metal buckets can be formed of one piece as shown in figure 6-a. The metal should be as heavy as required by the size and power of the wheel, and should be carefully bent into the required shape. This is given from the radial depth "A", the radial distance "R", the length of chord "C", the pitch "P", and the depth of the curvature "E". The arc of the bucket curve is the arc of a circle. Bending should be done in such a manner that there are no sharp corners. With metal soling the bucket edge is bent back and fastened at one place only, as shown in figure 6-b. When wooden soling is used, the bucket edge is bent under with an angle brace bolted to the next following soling plank, as shown in figure 6-c. This arrangement will give the strength required at this very important detail of the wheel.

(H) CHECKING FINAL DESIGN DETAILS.—After the kind of materials have been decided upon and all details of the design have been planned carefully, working drawings should be made from which the wheel will be constructed. Where the wheel is to be made up in a shop, blueprints may be necessary. Ordinarily, however, large scale, carefully made, pencil drawings will be satisfactory. Detailed dimensions for each piece, and also an assembly drawing, showing how all the parts will fit together, will be valuable for checking all clearances. If these drawings are carefully made, much time will be saved in cutting and assembling the wheel, and costly mistakes can easily be avoided.

### 3. LAYING OUT THE WHEEL AND CUTTING PARTS TO PROPER DIMENSIONS

Radial arms, bucket parts, soling sections or planks, and shrouding sections can be cut to shape before any assembly is made, provided careful working drawings have been made showing the shape and size of each piece. At least the most important holes should be drilled so that assembly can be made easily. Bracing is usually better when cut to fit, and therefore is not cut until assembly is made. Likewise, small metal reinforcements, except when of some standard shape, need not be made up until needed in assembly. In construction of wooden wheels it will sometimes be necessary to cut timbers to a given angle. Appendix I gives directions for using an ordinary steel square in cutting these angles. Particular care should be given in cutting the ends of the radial arms (if wooden arms are used) and fitting them snugly into the hubs without any play. If this is not carefully



done, they may be seriously weakened at the critical point where they leave the hub.

#### 4. CONSTRUCTING WHEEL MOUNTINGS AND TAIL RACE

(A) WHEEL MOUNTINGS.—Masonry or concrete pillars will make the best mounting for a wheel, although heavy piling or timbers have also been used successfully. Foundations should rest on a solid base—firm gravel or bedrock if possible—to avoid danger of settling. Large area footings will also help, and will prevent damage from stream erosion. If one end of the shaft is supported at the power plant building, this support should be as solid as the outer pillar.

Provision should be made for adjustment in the alignment of the bearings in case one of the supports should settle or slide. Wooden blocks can be used to mount the bearings, and these can be changed to adjust for any difference in elevation or placement. It is very important, of course, that bearings and wheel shaft be kept in perfect alignment at all times.

(B) BEARINGS.—With good bearings more power will be available for useful work. They should be large and rugged to stand years of service with but little attention. Roller bearings, such as are found in mowing machines and similar farm machinery, are good for small sized wheels. Bronze journals are widely used for water wheels and are quite satisfactory. With larger wheels, which turn slowly, babbitted bearings are satisfactory. Water must be kept out of all bearings which are not designed to work in water. This is best done by keeping them well packed with grease, which may be applied by a grease gun or pressure grease tank. Open cup journals should never be used.

(C) THE TAIL RACE.—If the discharge or tail water is not immediately removed from the vicinity of the wheel, wading will result, causing a serious loss of power. However, the drop necessary to remove this water must be kept at a minimum in order to lose as little as possible of the total available head.

Experiments have shown that if the water is allowed to discharge toward the *rear* of the wheel, in other words, in the direction the lower part of the wheel is moving, less clearance will be necessary under the wheel than if the water discharges toward the front, or downstream. The best method to accomplish this is to place a pan or apron of concrete or smooth rock under the wheel, sloping gently toward the rear as shown by the dashed lines in figure 1-a, and extending well enough to the front to catch most of the normal discharge water. The apron slopes steeply to the stream bed so that overflow, resulting from an abnormally heavy flow of water over the wheel, will not be carried under it. This

arrangement will require that provision be made for bringing the discharge water from the lower end of the pan back into the stream bed by forming a smooth, sloping channel around the outer end of the wheel. This discharge channel should be very smooth and evenly sloped well down the stream bed below the wheel.

#### 5. MOUNTING THE AXLE ASSEMBLY AND ASSEMBLING THE WHEEL

(A) THE AXLE ASSEMBLY.—The hubs should be securely fitted on the drive shaft or axle, *with care taken to see that the radial arms will be accurately in line*. Welding, keying, or splining are recommended. A pin through a hole drilled in the axle should be used only for small, light duty wheels. Often it is desirable to mount the drive sprocket or pulley on the shaft before it is placed in the bearings.

In mounting the shaft in the bearings, carefully avoid any damage to the bearings and to the shaft. For heavy shafts an overhead lifting gear to swing the shaft into place is recommended. *Shaft and bearings must be brought into accurate alignment and solidly secured in place before any assembly of the other parts of the wheel is made*. However, small wheels, particularly those of the all-metal type, may be completely assembled before mounting. During the mounting process very great care is necessary to avoid springing the wheel or damaging its buckets or other parts.

(B) ASSEMBLING THE WHEEL.—First the radial arms are placed in the hubs, accurately lined up, and then securely wedged and fastened in place. The shrouding plates are next put on, holding the radial arms in place and providing an outer framework for the wheel. The soling then goes on, and with it the necessary transverse and other bracing. The buckets, of course, are assembled last. With the use of wooden soling, caulking should be done at time of construction. Every precaution should be used that the soling and shrouding form a watertight wheel, for any leakage will decrease its efficiency.

#### 6. BALANCING THE WHEEL

Wheels must be carefully balanced if they are to run smoothly, without uneven wear, or excess strain on the supports. When the wheel is completed and properly mounted, it should turn easily and come to a smooth, even stop. If unbalanced, it will swing back and forth for a time before stopping. In case this happens, add a small weight (such as a few nails or an additional bolt), at the top of the wheel while it is in a rest position. With care, just enough weight can be added to balance the wheel perfectly.

### 7. DELIVERY OF WATER TO THE WHEEL

For the highest efficiency, water must be delivered to the wheel from a chute placed as close to the wheel as possible, and arranged so that the water falls into the buckets just before they reach upper dead center. The relative speed of the buckets and the water is very important. For these reasons, an accurately built "chute" is generally used to deliver the water to the wheel.

The speed of the wheel will be reduced as the load it is driving is increased. When large changes take place in the load, it is necessary to change the amount of water or the velocity of its approach to the wheel. This is done by a control gate located near the wheel, which can be raised or lowered easily and fixed at any position to give a moderately accurate adjustment. The best device for this is a gate stem and wheel. A simple headboard arrangement which will also work quite well is shown in figure 7.

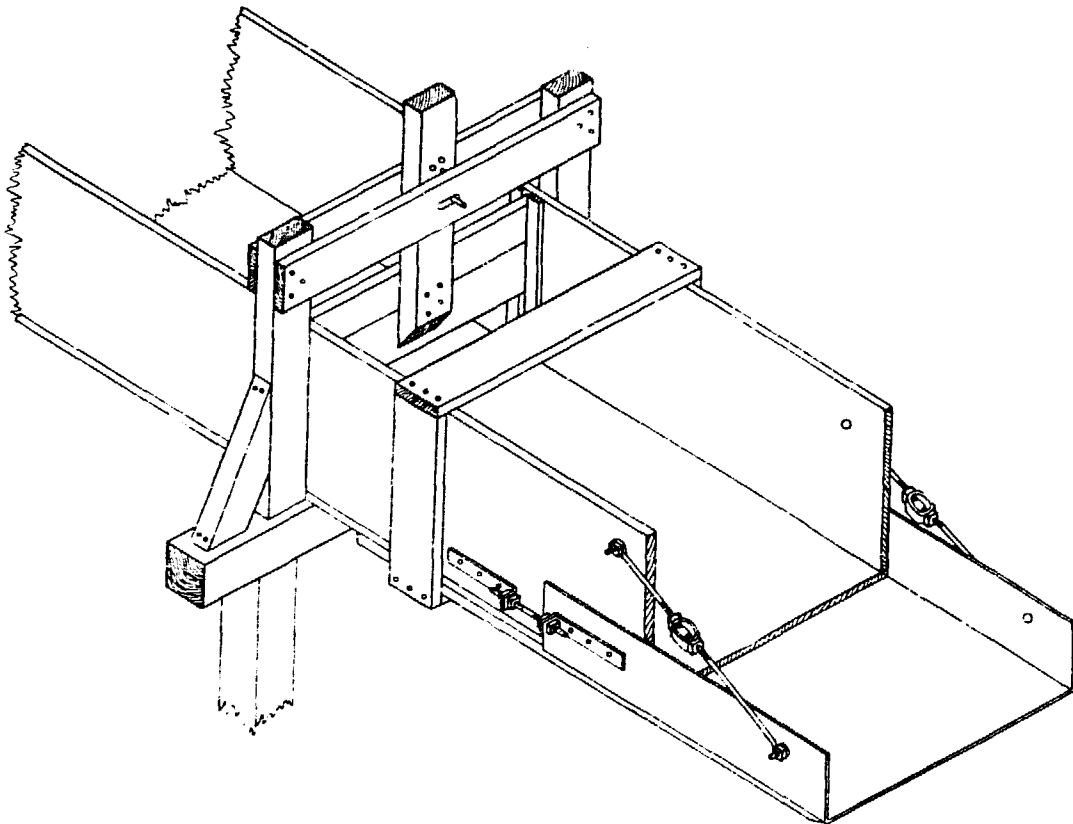

FIG. 7. DETAILS OF DELIVERY CHUTE.

The chute should run directly from the control gate to the water wheel, and be as short as construction will permit (from 1 to 3 feet long is best). A little slope is necessary to maintain the water velocity (1 per cent or 1 foot in 100 will be satisfactory in most cases). Flat-bottomed chutes are preferable, and even when water is delivered through a pipe, this should terminate in a con-

trol box, and make delivery to the wheel through an open, flat-bottomed chute. The tip of the chute should be perfectly straight and level, and lined with sheet metal to prevent wear. There should be some provision so that slight adjustments may readily be made in the tip of the chute to correct for any change in its position or in the control box. A suggested arrangement for making these allowances is shown in figure 7.

The delivery chute is never quite as wide as the water wheel. This is to allow air to escape at the ends of the wheel as water enters the buckets. The chutes for ventilated wheels can be correspondingly wider than those for non-ventilated wheels.

### 8. THE POWER DRIVE

For most purposes it will be necessary to increase the speed of the drive shaft before it can be used satisfactorily, especially for electrical generation which will require from 30 to 1, to 60 to 1 speed ratio. Such a speed ratio can seldom be gained efficiently in a single step, so a jack shaft such as shown in figure 8 will be needed. The slow speed drive, from the water wheel to jack shaft,

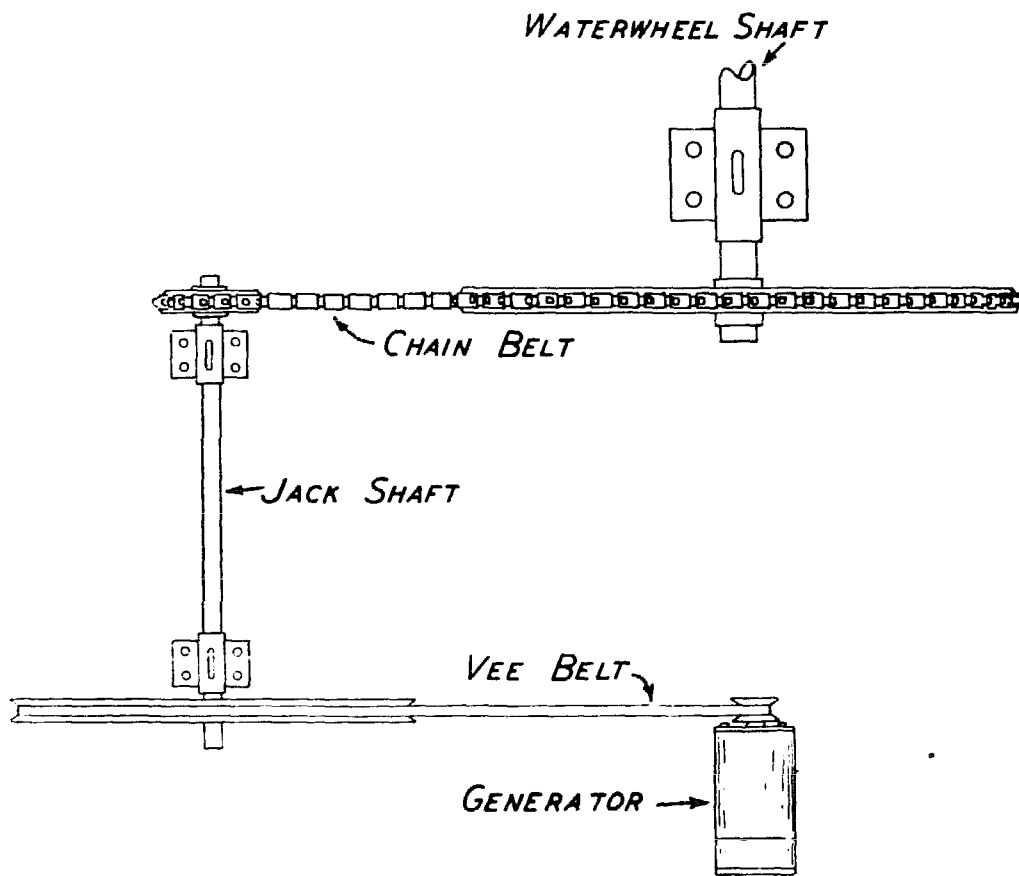

FIG. 8. A JACK SHAFT ARRANGED TO DRIVE A GENERATOR FROM AN OVERSHOT WATER WHEEL.

will require a much heavier belt or gearing than for the faster drive from shaft to the generator. For this reason, a reduction of not more than 5 to 1 or 6 to 1 should be attempted on this slow speed drive. A long belt will often be necessary to give a good grip on the small pulley. V-belts have been tried for this step, but are not satisfactory because of the high tension which must be used. Flat leather belts, particularly those with special treads, have given the best satisfaction. Chain drives have also been used successfully for this first step.

On the drive from the jack shaft to the generator a smaller belt, and also smaller sized pulleys, can be used, because of the higher speed of operation. V-belts work well on this part of the drive, often being run over a flat drive pulley with a V-groove on the generator pulley. Gears work well on either or both steps, but usually must be made specially for the drive, and are therefore expensive. Carefully designed and constructed drives, mounted in good bearings, should deliver from 85 to 90 per cent of the power output of the water wheel. Unless care is taken, however, the transmission efficiency may be much less than this.

#### 9. SHELTER FOR THE WHEEL

Water wheels equipped with shrouds, and running with rim velocities of 6 to 8 feet per second will seldom freeze even if exposed in severe winter weather. However, all danger from freezing can be eliminated by housing the wheel, and this is recommended for all overshot wheels in Montana. Either the wheel may be placed inside the power house, or an external housing built as shown in figure 9. This should be so arranged that the wheel

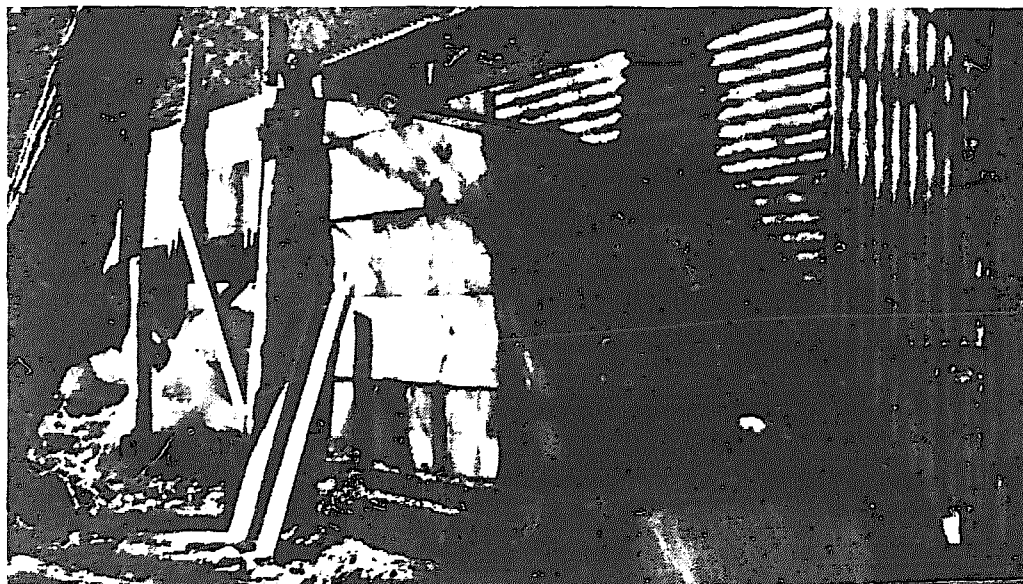

FIG. 9. HOUSING FOR AN OVERSHOT WATER WHEEL.

is accessible for inspection and repair without difficulty. Bearings should be readily accessible. A slip door should be provided for inspection and cleaning of buckets. It should also be possible to inspect the chute and readily adjust the position and alignment of the tip. Even major repairs should be possible without completely dismantling the wheel cover or the power house.

## CURRENT WATER WHEELS

### DESIGN, CONSTRUCTION AND INSTALLATION

Current wheels are particularly useful for lifting water directly by means of buckets attached to their rims, or for driving slow speed pumps. Because their rotational speed is generally so very slow, they are not well suited for generating electricity. However, the available head may sometimes be so low that no other style of wheel is practicable. In such a case, current wheels can be used if there is plenty of water available, and if provision is made to use as large a percentage of the available water as possible.

When these wheels are used to lift water, the effective lift will be one-half to two-thirds of the wheel diameter; so the height of such lift will determine the diameter of the wheel. Wheels should be made with as small a diameter as is needed to give a satisfactory lift. This will make them lighter in weight, and will increase their rotational speed.

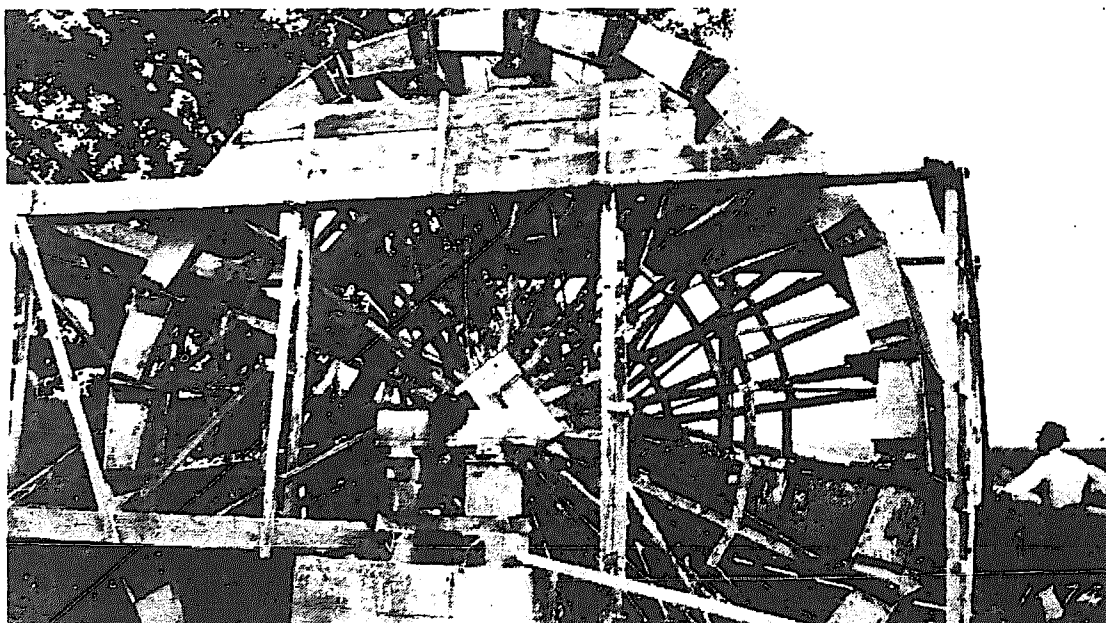

FIG. 10. CURRENT WHEEL WITH BUCKETS FOR LIFTING THE WATER.

The power which a current wheel can develop depends upon the area of contact each paddle has with the water in the stream, and also upon the velocity with which the stream moves. The number of paddles makes no difference as long as two or three paddles are always in the water. Wheels of this type operate best when the paddles move with an average velocity of approximately one-half that of the stream. Increasing the stream velocity will therefore allow a faster speed for the wheel, and since it also enables more water to pass under the wheel, the power output will be greatly increased. Computations show that doubling the stream velocity with a given paddle area in contact with the water will increase the theoretical power output of a current wheel eight times.

The area of paddle contact in the stream is limited by the length of the wheel, and by the fact that paddles should dip into the stream only about one-tenth of the wheel diameter for best results. Thus a wheel ten feet in diameter and ten feet long should have a normal paddle contact area of approximately ten square feet. The best way to increase the power output of a current wheel, therefore, is to increase the velocity of the stream.

Many different styles of construction have been used on these wheels, and it is possible to use all-metal, or wood and metal construction as has been described for the overshot wheels. However, only an all-wood style of wheel is described here, as such will probably be the most practical for homemade installations. This wheel design was originally used in Fresno, California.\* It requires no rim, and very simple radial bracing. As with overshot wheels, all parts should be amply heavy to withstand any strain which may be placed upon them. Paddles should be of finished lumber. Braces and radial arms can be rough timbers, provided they are accurately cut.

The design, construction, and installation of a current wheel should follow the same general outline as that given for overshot wheels, namely:

1. Determine the major design dimensions and specifications for the wheel.
2. Select the materials, and decide on minor features of design and arrangement.
3. Lay out the wheel and cut parts to proper dimensions.
4. Construct wheel mountings, approach flume, water controls, etc.
5. Mount axle assembly, and assemble the wheel.

---

\*Any person planning to construct a farm water wheel should write to the Irrigation Department of the Montana Agricultural Experiment Station, Bozeman, Montana for an information blank. When this is returned, properly filled out, definite information about the size and kind of wheel will be sent.

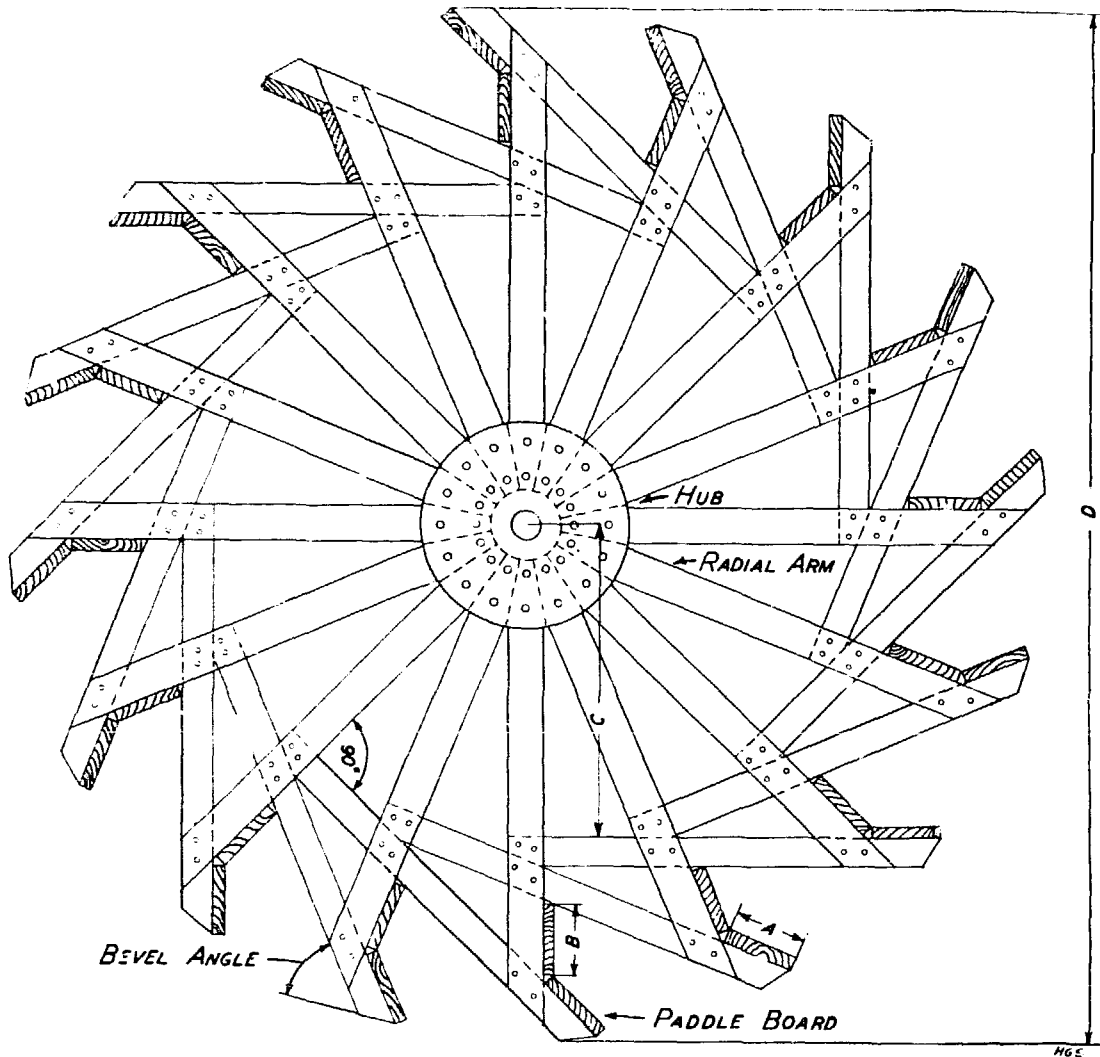

FIG. 11. CURRENT WHEEL CONSTRUCTION.

6. Balance the wheel.
7. Assemble the power drive.

Most of the suggestions and remarks pertaining to overshot wheels will also apply to current wheels, and therefore will not be repeated.

### 1. DETERMINATION OF MAJOR DESIGN FEATURES AND SPECIFICATIONS

The type of current wheel will depend to a great extent upon the method of mounting which may be used. These wheels can be hung directly over the stream, without the use of any water controls or any type of approach, but when so hung they use but a very small part of the energy available in the stream. More commonly the water is diverted into a ditch or flume over which the wheel is mounted. This allows control of the water to the wheel,



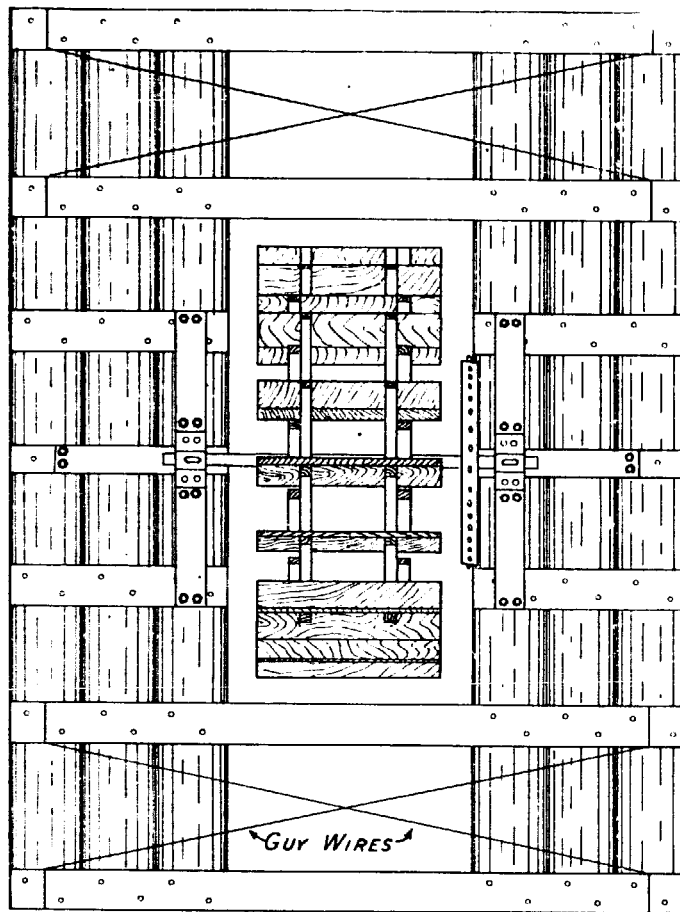

PLAN

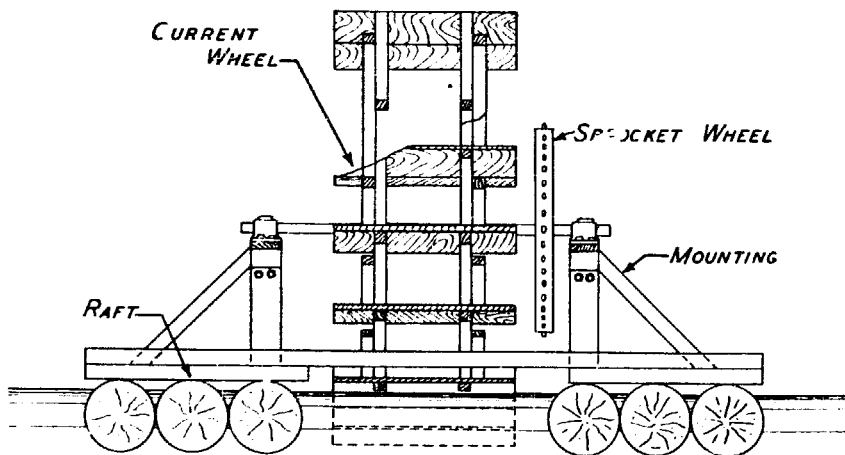

ELEVATION

FIG. 12. A RAFT MOUNTING FOR A CURRENT WHEEL.

and, if a smooth flume is used, a considerable increase in stream velocity and therefore of available power is possible. A third type of mounting, used occasionally, is a raft. Such a raft is shown in figure 7, moored in the stream. With this mounting the wheel operates much as if it were hung over the stream, except that it need not be adjusted for water level. Efficiency is low as for any open mounting, and in other respects the wheel is the same as those used with other mountings.

## 2. SELECTION OF MATERIALS AND DETERMINATION OF MINOR DESIGN FEATURES

Except for differences in design which are apparent from the diagrams, most of the information given for overshot wheels, particularly that on axles, hubs, radial arms, and bracing, will also apply to current wheels. In general, current wheels will be larger, and will run slower than corresponding sizes of overshot wheels. Therefore all parts must be much heavier. Use of wooden axles is not uncommon, and even some wooden bearings have been used satisfactorily. Bracing and reinforcing is particularly important and must be thoroughly and carefully done.

(A) PADDLES.—A current wheel operates by checking the flow of a stream. Under ideal conditions the wheel would hold back all the water, and thus acquire all of its energy. In actual operation this is not possible, for the water must flow away from the wheel. However, a properly designed wheel will check the flow as much as possible without causing the discharge water to impede the action of the wheel. To keep energy losses small, the paddles should enter the water without splashing, and should leave the water in a vertical position. The paddle design shown in figure 11 does these things about as well as will any paddle made of flat boards. As the velocity in the stream is checked, the water in front of the paddle will back up against the inner, or upper, paddle board. The arrangement of these boards will keep the water from splashing over the top of the paddle if the wheel is mounted at the proper height above the stream or flume.

## 3. LAYING OUT THE WHEEL AND CUTTING PARTS TO PROPER DIMENSIONS

As with overshot wheels, detailed working drawings are recommended. If these have been prepared, parts can be cut properly without difficulty. Some may prefer, however, to lay the wheel out on a smooth piece of ground, as it will actually be constructed, and to mark and cut the timbers to fit. In any case the specified bevel angles should be cut by use of a steel square as given in Appendix I.

#### 4. CONSTRUCTION OF WHEEL MOUNTINGS, APPROACH FLUMES, TAIL RACE, ETC.

(A) MOUNTING. — Current wheels have been successfully mounted on piers placed in the stream, or have been supported in a cantilever fashion from a support on one bank of the stream. A few have been mounted successfully on rafts floating on the stream. A well made raft will probably be quite satisfactory, as it eliminates the necessity of raising and lowering the wheel for changes in water level. However, care must be taken that the raft will have enough buoyancy to support the wheel and necessary auxiliary equipment, and, of course, it must be well secured to the banks of the stream. A good way to estimate this buoyancy is to multiply the volume of the logs in cubic feet by 40. This gives the number of pounds of water displaced when the logs are roughly two-thirds submerged. This value should equal or exceed the total weight of the wheel, raft (including the logs), and all auxiliary equipment which the raft must support.

For other forms of mountings over open streams, provision must be made to raise and lower the wheel with changes in stream level, and to raise the wheel entirely out of the water during the winter. Suggestions for mountings of this type are given in figure 13.

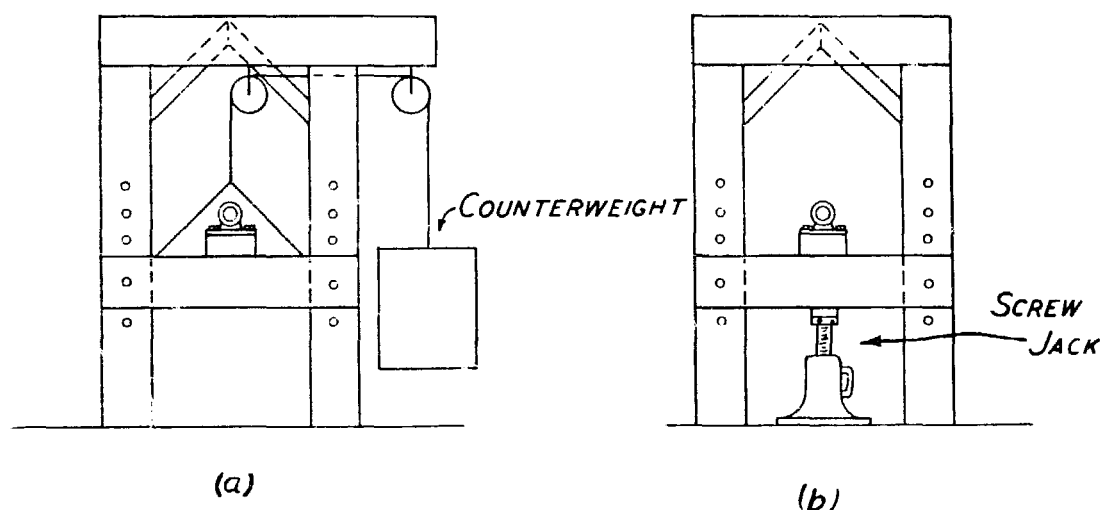

FIG. 13. LIFTING MECHANISMS FOR CURRENT WHEELS.

Wooden shafts, and even wooden bearings, are commonly used on very large current wheels, but, in general, bronze or bab-bitted journals, with a metal shaft, or at least a metal-bearing surface on the shaft, will be much more satisfactory.

(B) USE OF AN APPROACH FLUME.—A smooth flume, built of lumber or cement, will considerably increase the velocity of the

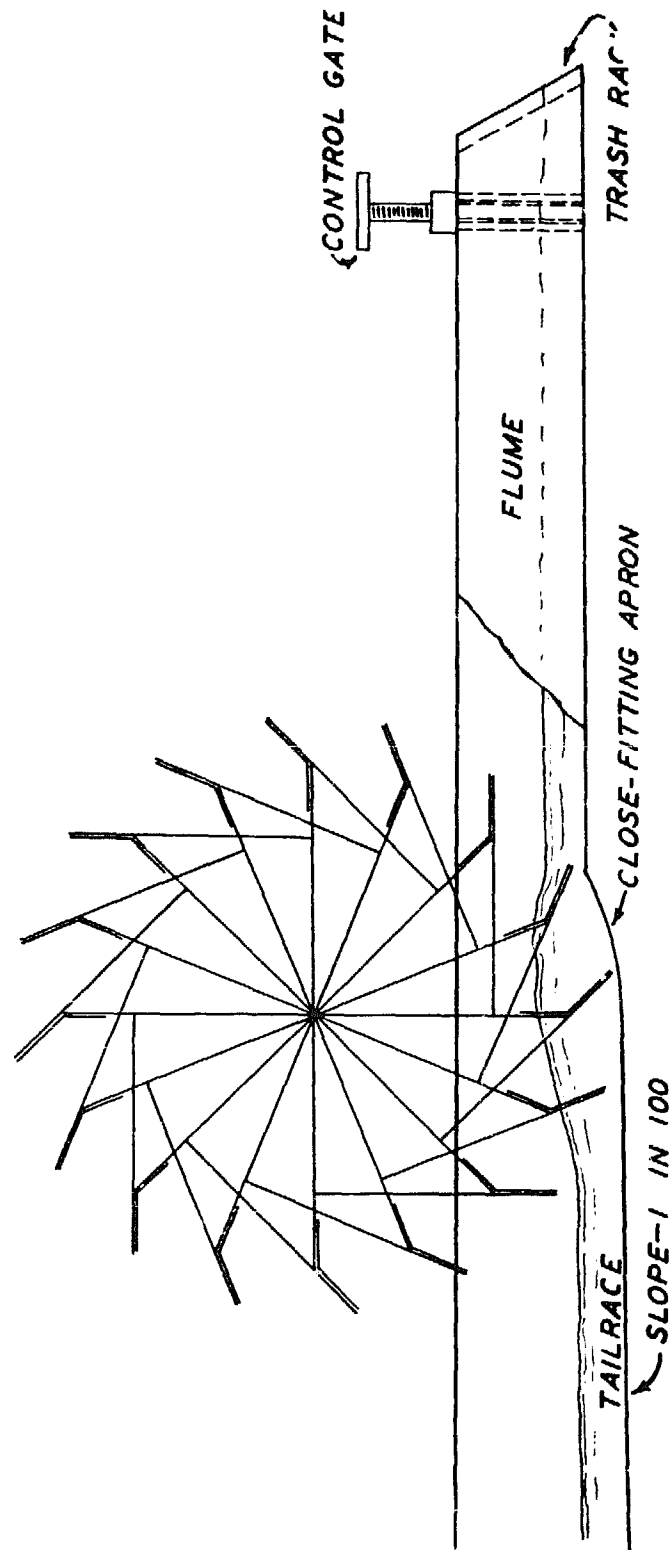

FIG. 14. ARRANGEMENT OF CURRENT WHEEL WHEN MOUNTED IN FLUME.

water under a current wheel, and this will greatly increase the available power. A flume of this type can be built on the same slope as the stream bed, and thus will not require elaborate supports. A low dam may be built to divert water into the flume, or

to increase the available head. A wheel mounted in such a flume can have a solid mounting without the adjustable features required over an open stream, as the stream flow in a flume can be regulated to maintain the most desirable level, and the water can be shut out entirely during freezing weather.

(c) **A TIGHT FITTING CHUTE UNDER THE WHEEL.**—The chute immediately under the wheel should fit closely to the paddle ends, allowing only enough clearance to prevent rubbing. Then the wheel should be mounted so that the clearance under the paddles at the bottom of the wheel is as small as possible. If construction is accurate, a clearance of a fraction of an inch will be sufficient. A chute shaped to fit the wheel as shown in figure 14 will give greater efficiency than a flat-bottomed chute.

(d) **THE TAIL RACE.**—The tail race should have as steep a slope as possible to allow the discharge water to escape rapidly even when discharged with a very low velocity. A smooth discharge channel should be provided far enough below the wheel to avoid the danger of backing up water from the stream into the wheel.

(e) **WATER CONTROL.**—Where a flume is used for a current wheel, control of the water by means of a simple board or head-gate is possible. This makes it unnecessary to raise and lower the wheel with changes in water level, and improves the operating efficiency of the wheel. A trash rack should be installed at the intake to eliminate danger of damage from debris. All intake approaches should be smooth and open, and constructed to make possible the diversion of enough water, the whole stream if necessary, into the flume to maintain a proper water level at all times.

#### **5 - 6. MOUNTING THE AXLES ASSEMBLY, ASSEMBLING AND BALANCING THE WHEEL**

Follow the directions given under similar headings for over-shot wheels. Assembly of the wheel will follow this order: axle, hubs, radial arms, bracing arms, and paddles.

#### **7. POWER DRIVES FOR CURRENT WHEELS**

Current wheels which deliver more than a small fraction of horsepower need very heavy drives because of the slow speed at which they operate. Unless direct drives to very slow speed equipment are possible, chains or heavy gears should be used. The wheel shown in figure 15 uses a heavy sprocket chain around the circumference of the paddles in the middle of the wheel for the first drive. Additional speed is obtained through a tractor transmission. For driving electric generators, a mechanism sim-

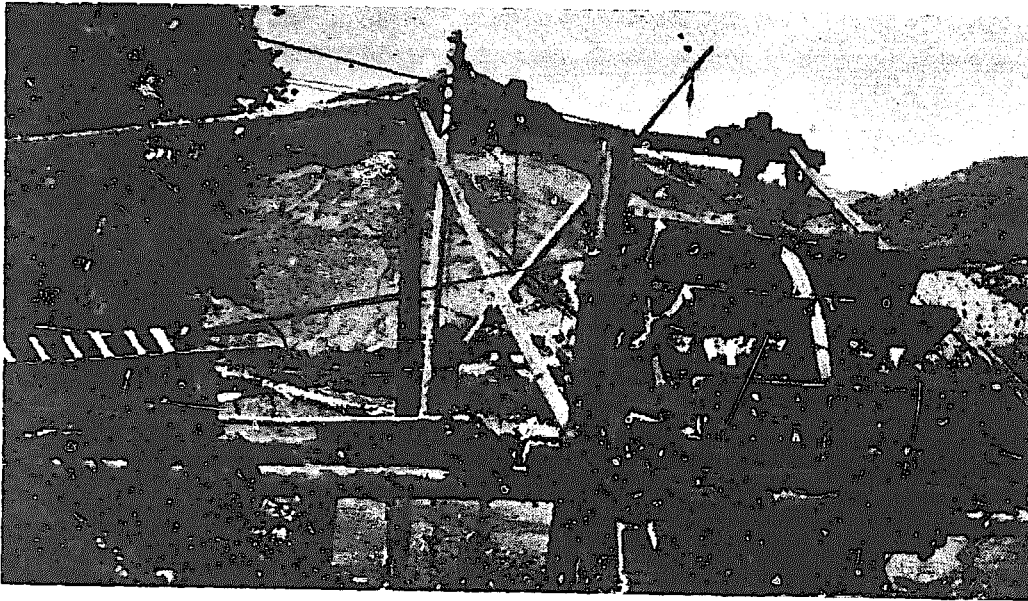

FIG 15. VIEW OF A CURRENT WHEEL SHOWING LIFTING ARRANGEMENT AND POWER DRIVE.

This wheel was built by Cutler brothers, Corwin Springs, Montana.

ilar to that described for overshot wheels will be necessary, although in general more than two steps are needed, and the slow speeds will require more rugged equipment for a given power output than is necessary for overshot wheels.

## APPENDIX I

## HOW TO LAY OFF ANGLES WITH A STEEL SQUARE

When it becomes necessary to cut a board at a given angle, as for instance, to cut the bevel angles for the paddle braces of current wheels, or to cut the beveled edge of the bucket tip for over-shot wheels, a steel square can be used as follows:

Lay the square across the board to be cut, as shown in figure 16. The edges which are graduated in eighths and sixteenths should be up. Measure all distances to the edge of the board away from the angle of the square. The distance along the body of the square is called "A", and the distance along the tongue of the square is called "B". All markings should be done along the tongue "B". Values of "A" and "B" to give a required angle can be found in table 2.

TABLE 2. DISTANCES FOR LAYING OFF ANGLES WITH A STEEL SQUARE  
(Mark along "B")

Angle Degree	A in.	B in.	Angle Degree	A in.	B in.	Angle Degree	A in.	B in.
30	8 3/8	14 1/2	40	6 1/2	7 3/4	50	7 3/4	6 1/2
31	10	16 5/8	41	8 1/4	9 1/2	51	10 1/2	8 1/2
32	7 1/2	12	42	9	10	52	8	6 1/4
33	6 1/2	10	43	7	7 1/2	53	8 1/8	6 1/8
34	6 3/4	10	44	7	7 1/4	54	13 1/4	9 5/8
35	7	10	45	10	10	55	10	7
36	9 5/8	13 1/4	46	7 1/4	7	56	10	6 3/4
37	6 1/8	8 1/8	47	7 1/2	7	57	10	6 1/2
38	6 1/4	8	48	10	9	58	12	7 1/2
39	8 1/2	10 1/2	49	9 1/2	8 1/4	59	16 5/8	10
40	6 1/2	7 3/4	50	7 3/4	6 1/2	60	14 1/2	8 3/8

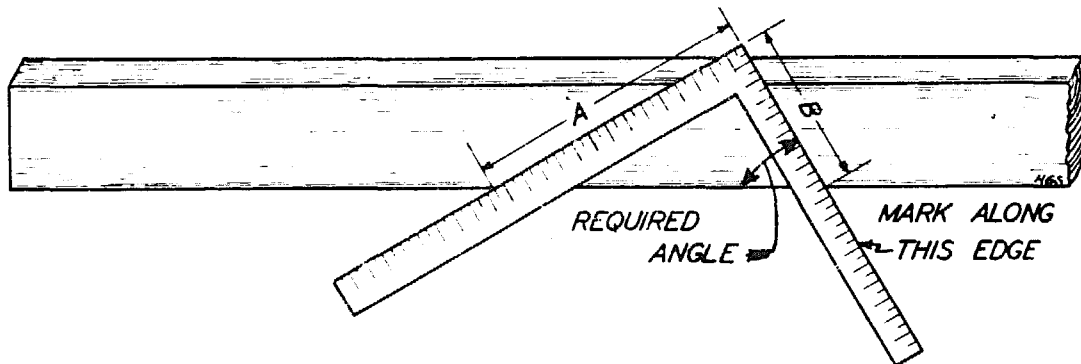

MARKING ANGLES WITH THE STEEL SQUARE  
(MARK ALONG EDGE B)

FIG. 16. MARKING ANGLES WITH A STEEL SQUARE.