

AT MICROFICHE
REFERENCE
LIBRARY

A project of Volunteers in Asia

Homemade Six-Volt Wind-Electric Plants

by: H.F. McColly and Foster Buck

Published by:
North Dakota Agricultural College
Extension Service
Fargo, ND USA

Paper copies are \$ 1.25.

Reprint available from:
Mother's Bookshelf
Box 70
Hendersonville, NC 28739 USA

Reproduction of this microfiche document in any form is subject to the same restrictions as those of the original document.

Special Circular

January, 1939

Homemade Six-Volt Wind- Electric Plants

H. F. McColly

Foster Buck

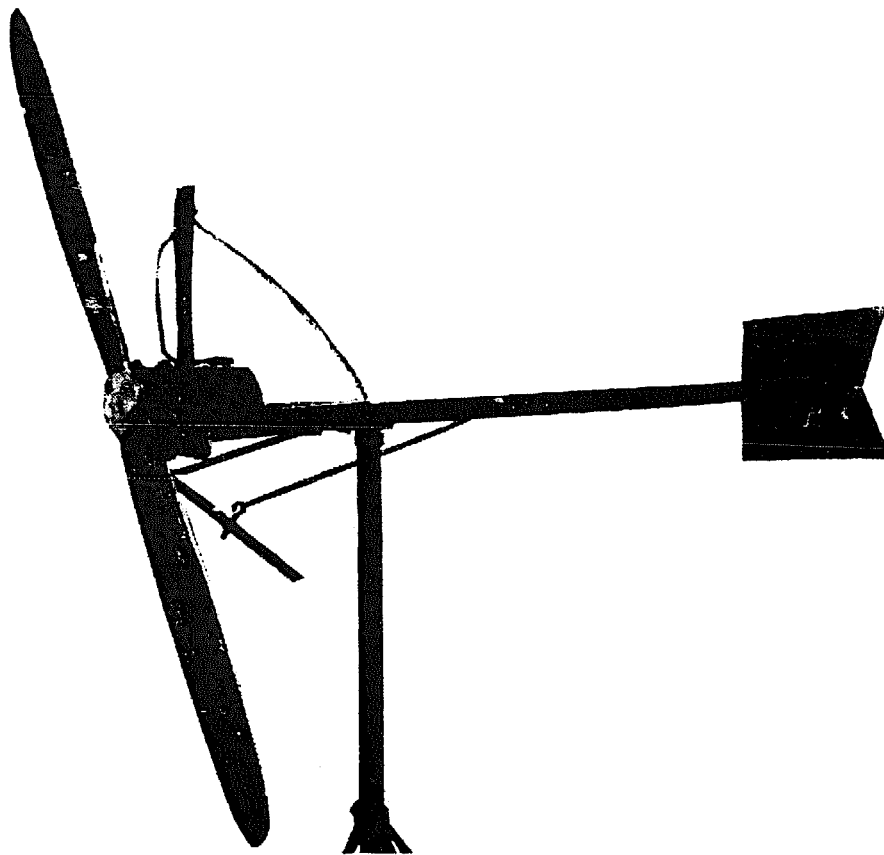

**NORTH DAKOTA AGRICULTURAL COLLEGE
EXTENSION SERVICE**

E. J. HASLERUD, Acting Director

Fargo, North Dakota



Exact reprint by THE MOTHER EARTH NEWS®, 1975, \$1.00

Homemade Six-Volt Wind-Electric Plants

by

H. F. McCOLLY,* Agricultural Engineer

FOSTER SUCK, Electrical Engineer

THE wind is a source of power that is universally available. The chief use of this relatively free power on the farm has been for pumping water. However, in the past few years there has been an increase in the use of wind power for generating electrical energy for charging storage batteries. The plants have been of a vast variety, from the simplest homemade wind-driven low voltage battery chargers to the complete high voltage wind-driven lighting systems.

This publication deals entirely with a homemade wind-driven 6-volt battery charger system which may be used to generate energy to keep batteries charged for radios, automobiles, tractor lights, and even small lighting systems for farm houses and other farm buildings where the energy consumption is not large.

In using the wind for producing electrical energy it is necessary to generate the energy at periods when a satisfactory wind is blowing, and store this energy for use during desired periods. It is impractical to have a wind driven plant supply energy direct to the power or lighting system. A storage battery system serves as the medium for storing the energy for use as desired.

More farm homes have not enjoyed the benefits of electric lights and electrically operated equipment because they have not had the means with which to purchase the common electric light plant. While the small low voltage system is not practical except for small loads, it will fulfill a long-felt desire by many rural families to enjoy some of the benefits of electricity and acquaint them with the possibilities of such service. This small homemade plant should not be expected to be the highest attainment in an electric system.

Requests from many individuals for information on how to build wind generating plants has prompted the design, development and tests on them thru the cooperative efforts of the departments of agricultural engineering and electrical engineering, made possible because of the assistance furnished by the Federal Emergency Relief student labor program.

There are many satisfactory small generating plants on the market. However, there are many enterprising and mechanically

NOTE—Published as Agricultural Experiment Station Circular 58 in December 1935. Revised and reprinted in November 1936 and now published as a special circular of the Extension Service.

*Mr. Albert Anderson, Instructor in Mechanical Engineering assisted in the early development of impeller blades.

Cooperative Extension Work in Agriculture and Home Economics, the North Dakota Agricultural College and the U. S. Department of Agriculture cooperating. Published and distributed in furtherance of the Act of Congress of May 8 and June 30, 1914.

handy farmers who desire to build their own plant and who would take pride in building such a plant by their own skill. The cost of materials for a homemade plant will range between five and fifteen dollars, depending upon the amount of equipment that is on hand.

USES OF THE PLANT

The plant furnishes its best utility in the storing of energy in batteries during periods when the wind blows, then using this energy to operate radios, tractor lights for night field work, or the lighting of farm buildings. The energy stored in the battery can be used at any time whether the plant is charging the battery or is not operating.

The amount that the stored energy of the 6-volt plant will be used for any one specific use will largely determine the lighting methods employed. If the plant supplies current to be used entirely in the residence then more lights can be used, especially at one time.

Central fixtures are the most common for the small plants and such fixtures will have many conveniences over non-electrical systems. For the kitchen, a central system with a no-shadow fixture has many advantages. The rest of the rooms should have consideration given to placing the fixtures where they will be used, instead of in the ceiling. For example, lights around the living room where people will be reading, and dresser lights in bedrooms are preferable to ceiling fixtures.

Where the plant out-put is limited, the family activities can be concentrated somewhat. That is, all the lights in the house will not need to be on at one time.

For supplying lights in the barn, the fixtures should be located at the work centers and switches conveniently placed so the lights can be controlled easily while doing the chores. Electric lights have many advantages in hay lofts and feed bins and should be placed in such places as well as in alleys, pens, etc.

Poultry house lighting is more complex and needs to be definitely planned and performed, otherwise it is better left alone. Early morning lighting is recommended for the 6-volt plant or any small plant. Turning on the lights at 4:30 to 5:00 o'clock in the morning has proven the best practice. It is a decided mistake to turn on the early morning lights without having feed and drink available to the flock. In many cases it will require artificial heating of the drinking water during cold weather.

An ordinary alarm clock of large size can be used to work a toggle type switch by letting the groove in the alarm winder lever fit over the switch so that it will snap the switch as the alarm rings. The clock will need to be clamped down. In case the switch is too stiff or the clock spring too weak, the switch should have an extension lever soldered or otherwise fastened to it to increase the leverage.

Best results in poultry house lighting have been secured by using 40 watts for each 200 square feet of floor space. Since 6-volt bulbs give more foot candles of light per watt than bulbs of higher voltage, a slight advantage is gained in the bulb size required. It is necessary to have reflectors on the lights to distribute the light on the floor and these reflectors and the lamps should be kept dust free as a very slight film of dust very materially reduces the amount of light.

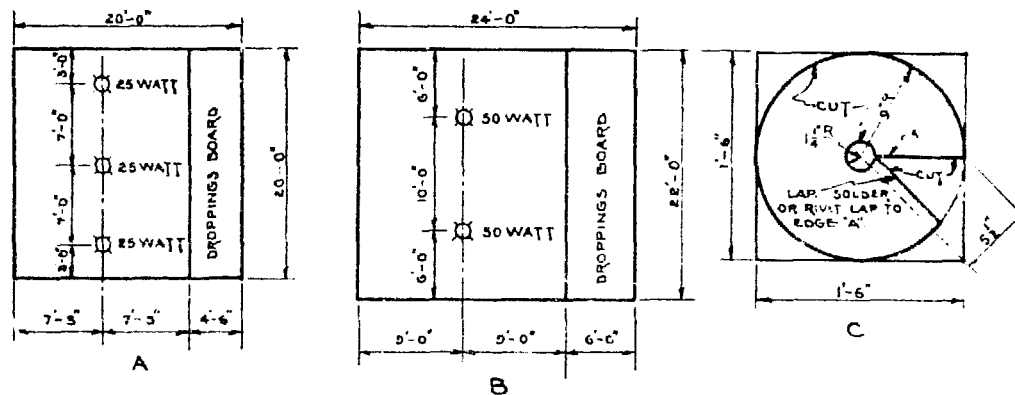

Figure 1. SPACING LIGHTS IN POULTRY HOUSES AND REFLECTOR PLAN
 A. Placement of three 25-watt bulbs in a 20 by 20 foot unit. B. Placement of two 50-watt bulbs in a 22 by 24 foot unit. C. Reflector 16 by 4 inches for distributing light.

The cuts show arrangements of lights for 20 by 20 feet and 22 by 24 feet poultry houses. The layout of a homemade reflector 16 inches across and 4 inches deep is also shown. The reflector can be constructed of light gauge sheet metal and painted with aluminum paint. The lights should be approximately 6 feet above the floor.

Poultry house lighting if correctly done will pay good dividends, but will yield no favorable results unless done completely as mentioned above. Natural winter days are too short for hens to feed, exercise, and lay eggs. Artificial lighting will lengthen the hours of activity of the birds.

It must be remembered that the capacity of the 6-volt system is rather limited and that one plant will not usually supply the lighting requirements for house, barn, and poultry house. More than one plant should be built for heavier requirements or a larger capacity plant considered.

CAPACITY OF THE PLANT

The average time the wind will run the plant at a charging rate will vary. An average of 8 hours per day is to be expected in most localities in North Dakota. There will be days with insufficient wind velocity while on other days the wind may blow 24 hours or more at a time. For this reason, sufficient battery storage capacity is desirable so as to make use of all the energy obtainable from the wind during the period it is blowing.

Reference to Table 1 shows the watt hours of energy that may be obtained from the generator per day for a given number of hours operation. Data in Table 2 indicates that two 6-volt automobile batteries of at least 125 ampere-hour capacity should be

used if all the watt hours of energy that the generator can put out in 24 hours operation is to be stored for later use. It is seen that using one battery would be entirely inadequate and that overcharging would result under such conditions.

The batteries are to be connected in parallel by wiring the positive terminals of the batteries together. The negative terminals are similarly connected together. The plans show the method of connecting the generator to the batteries.

Table 1 gives the hours that two 50-watt bulbs may be used for any given average hours that the wind may blow. In Table 2 is given the hours that one 50-watt bulb may be used in case of a calm of several days. Bulbs smaller than 50-watts will serve many lighting requirements.

Table 1.—DAILY ENERGY OUTPUT OF SIX-VOLT GENERATOR

| Average hours of plant operation per day at 11 amp. charging rate. | Average watt hours of energy output per day. | Approx. number of 50-watt bulbs operated 5 hours per day. | Approx. time two 50-watt bulbs may be operated. | |
|--|--|---|---|------|
| | | | Hrs. | Min. |
| 4 | 264 | 1 | 2 | 30 |
| 6 | 396 | 1½ | 3 | 45 |
| 8 | 528 | 2 | 5 | 0 |
| 10 | 660 | 2½ | 6 | 15 |
| 12 | 782 | 3 | 7 | 30 |
| 16 | 1056 | 4 | 10 | 0 |
| 20 | 1320 | 5 | 12 | 30 |
| 24 | 1584 | 6 | 15 | 0 |

Table 2.—ENERGY STORAGE CAPACITY OF SIX-VOLT BATTERIES

| Number of six-volt batteries | Amp. hour rating of each battery. | Watt hours storage capacity. | Number of hours battery will light one 50-watt bulb. ¹ |
|------------------------------|-----------------------------------|------------------------------|---|
| 1 | 80 | 480 | 10 |
| 1 | 100 | 600 | 12 |
| 1 | 125 | 750 | 15 |
| 1 | 150 | 900 | 18 |
| 1 | 175 | 1050 | 21 |
| 2 | 80 | 960 | 20 |
| 2 | 100 | 1200 | 24 |
| 2 | 125 | 1500 | 30 |
| 2 | 150 | 1800 | 36 |
| 2 | 175 | 2100 | 42 |

¹Without charging during discharge period.

There are four general sizes of wind plants. Regular 6-volt or 12-volt automobile generators are used on the most common wind driven plants. The other types of plants are much larger in size and generally use 32-volt or 110-volt generators for supplying both power and light. This publication describes the arrangement for using a 6-volt generator as it is the easiest home made plant to build and works satisfactorily for lighting and radio use.

There are many different arrangements that can be used in making a plant. The two plans in this bulletin show how a simple wind charger can be made by the ordinary person, with the common tools found in most homes. Either of the described plants will give satisfactory results when constructed as shown in the plans.

PLANT LAYOUT OF PLAN 1

The plant assembly illustrated in Figure 2, shows the use of a heavy generator directly coupled to an impeller. The cutout may be fastened to the top of the generator the same as in a car, as shown in the figure. A better method is to locate the cutout near the battery and ammeter.

The generator is mounted on a 2-inch by 4-inch board about 23 inches long. The generator must be very securely clamped to this board by two strap irons fastened with bolts. Since the wind exerts considerable pressure against the impeller, and thus to the generator, the generator must be rigidly fastened to the board to eliminate all end and side motion.

The board holding the generator in place has a 1-inch floor flange fastened to it by four one-fourth-inch by 2¼-inch stove bolts. Screws should not be used as they will work loose over a period of time. A 12-inch length of 1-inch pipe can be screwed tightly into the floor flange. A 1-inch hole bored thru the board to line up with the hole of the 1-inch pipe will allow the generator wire and the sash cord to pass thru the inside of the pipe. The 1-inch hole should be rounded where the sash cord pulls over the edge to eliminate wear on the cord. A 1¼-inch pipe about 6 or 7 feet long provides a sturdy mast into which the 1-inch pipe fits very nicely. The floor flange provides a good bearing for the upper end of the 1¼-inch pipe, thereby allowing the plant to line up easily in the wind.

Referring to the plan, the tail piece is made by tapering a 2-inch by 4-inch board 48 inches long down to 1½ inches wide at the tip. A saw cut in the center of the end allows a place to insert the sheet metal tail fan. The shape and dimensions are clearly illustrated on the drawing. The tail assembly is bolted to the generator assembly end by a heavy strap hinge with eight one-fourth inch by 4-inch carriage bolts.

The pull-out lever and governor vane lever are made from 1-inch by 2-inch strips and are mounted as shown. It may be necessary to make a slight change in the pull-out lever, according to the length and size of the spring used.

By pulling the sash cord the generator can be pulled out of line with the tail about 90 degrees. This will turn the generator out of the wind so it will not run and permits the plant to be stopped when desired.

Referring to the plant layout drawing, it is noticed that the tail assembly is held in place by a hinge and a spring. As the wind velocity increases, the pressure against the governing vane also increases. This turns the plane of the impeller endwise to the wind. Actually the tail maintains its position relative to the wind, but the plane of rotation of the impeller is at an angle to the wind. This tends to prevent the generator from over-speeding in a heavy wind.

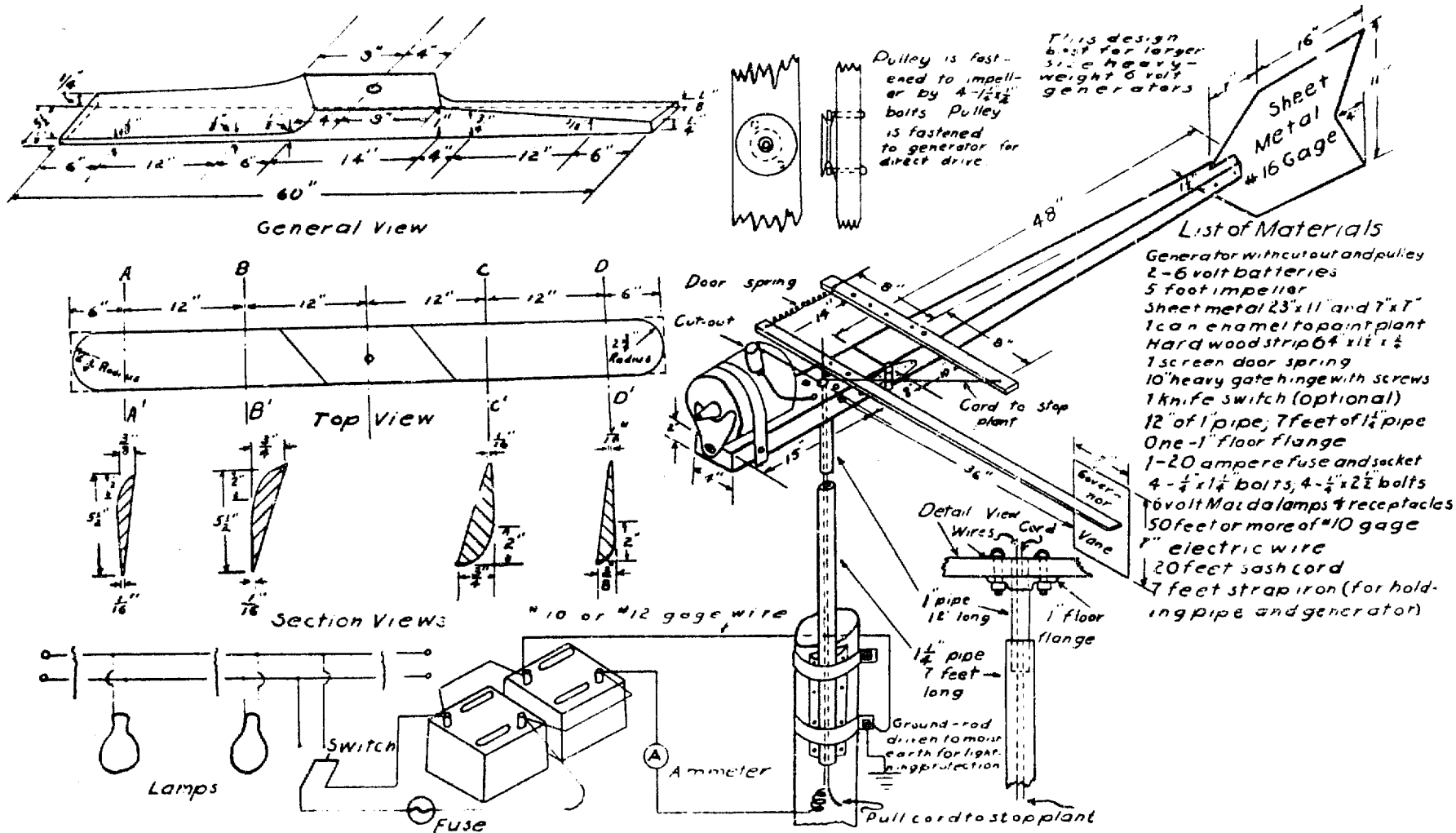

Figure 2. SIX-VOLT BATTERY CHARGER AND LIGHTING SYSTEM
 This design should be used for large heavy generators.

The wire from the frame of the generator and the wire from the cutout may be run down thru the 1-inch hole. These wires may be of insulated electric light wire, sizes No. 12 or No. 10. In case the cutout is located at the battery, the wire normally connected to the cutout will be fastened to the generator terminal post. In this case there will be a slight amount of twisting of the two wires as the plant changes direction when the wind changes direction. This is of no serious consequence, however, if a coil of several turns is formed in the wires where the wires leave the pipe.

To protect the plant from the elements and to make it look attractive, it should be painted with several coats of enamel. Since oil paints will not stick to metal satisfactorily, and there are not many wood parts, it is easier to enamel the entire plant. Any bright color such as orange or red makes an attractive looking plant.

PLANT LAYOUT OF PLAN 2

The generating plant shown in Figures 3 and 4 is a very satisfactory type for generators of light or medium weight. The principal difference is in the speed governing device, which makes a simpler plant that is more easily constructed. Speed regulation is accomplished by the wind exerting a pressure on the impeller blade, thereby tipping the generator and impeller upward according to the pressure exerted. The spring provides a restraining force that prevents the generator from tipping up too easily.

The supports holding the generator can be made from hardwood, light angle iron, or strap iron. Hardwood strips as wide as the thickness of the 2-inch frame, and 1-inch thick work very well. The length is about 16 inches, or they should be long

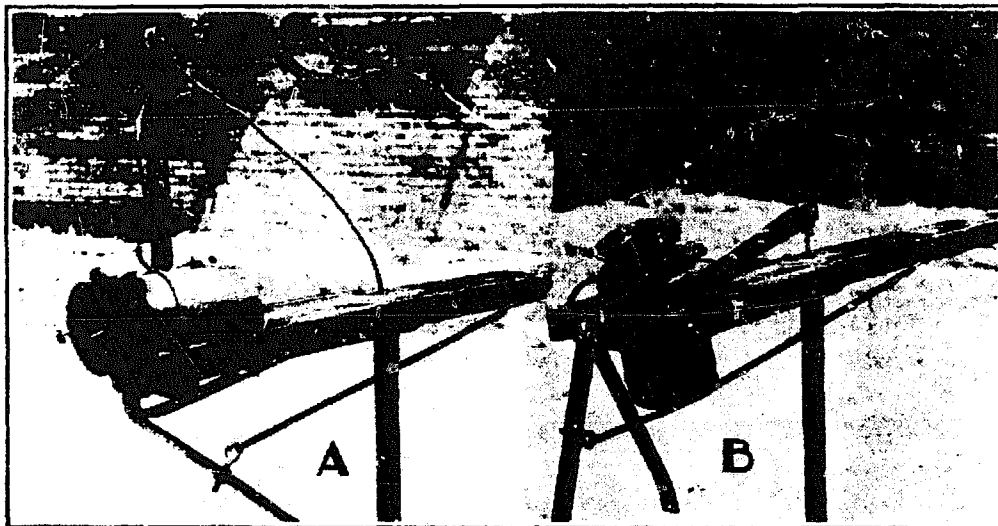

Figure 3. PIVOT TYPE GENERATOR

Long model of generator
 A. General view.
 B. Shut-off position.

enough to allow the type of generator to tip or oscillate freely. These strips should be securely bolted to the main part of the frame. The diameter and length of different makes of generators will vary, so it will be necessary to arrange the distance between supports and their length to suit the generator at hand.

A strap iron should be clamped around the generator allowing enough to extend above it for easily pulling the plant out of the wind. This strap can be long enough to be nearly over the mast pulley when the plant is out of the wind. Two studs should be fitted thru the band to serve as the pivot points. These studs may be made from three-eighths or one-half inch carriage bolts with the threaded portion sawed off and the heads filed quite flat to fit against the generator. The studs must be at right angles to the side strips and located at least 2 inches below the center of the generator. Bushings are necessary in the wood strips to maintain a reasonably secure pivot. Pieces of gas pipe or bushings from old machinery can be fitted to the studs.

To keep the generator and impeller from tipping down out of line it is necessary to have a stop iron. Material one-fourth inch

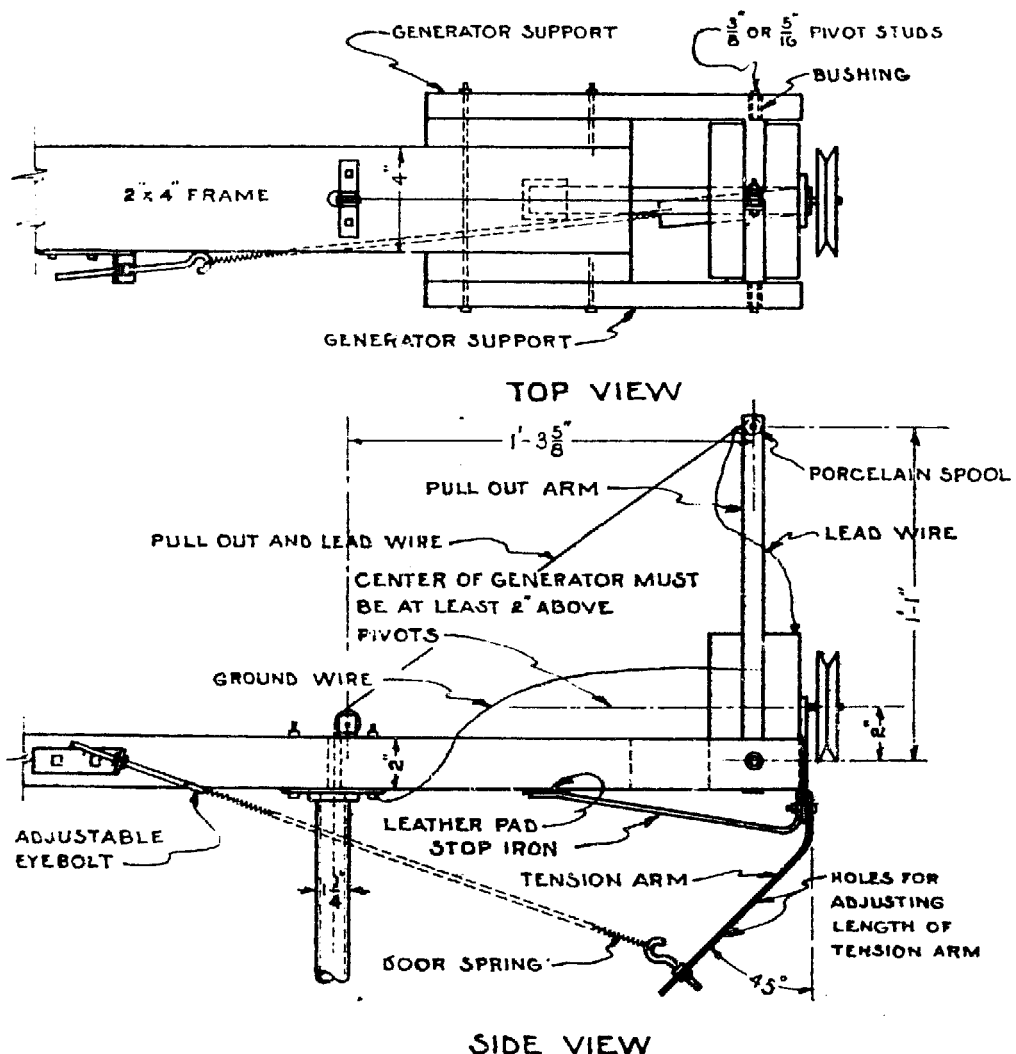

Figure 4. DESIGN OF PIVOT TYPE GENERATOR MOUNTING
Large diameter, short type of generator.

thick and an inch or more wide is satisfactory. Most generators have a mounting flange on the front end, and the stop iron, as well as the tension arm, can be bolted to this flange. The stop iron can then be bent in the proper shape for the back end to strike against a leather pad placed on the 2 by 4 inch frame. The leather pad decreases the tendency to "hammer."

Enough tension should be placed on the spring to hold the plant straight into the wind until it should begin to decrease its speed. The spring at the bottom of the combined lead and pull-out wire should have enough tension to keep the wire from kinking when the plant tips up.

The pull-out wire is made of a heavy weight bare copper aerial wire or flexible galvanized steel wire clothesline. This wire should be made up of several strands of small wire so as to be quite flexible. One end of this wire is fastened to the generator clamp band as shown in the drawing. The wire is insulated from the metal band by wrapping around a porcelain spool clamped between the ends of the band as shown in the detail view. Enough wire is left beyond the spool to go to the generator terminal post. The other end of the wire is left long enough to reach from the spool over the pulley down thru the pipe mast to the swivel. A sash pulley or any flanged pulley will serve the purpose. This pulley must have no metal connections to any of the pipes or floor flange bolts. Wood screws can be used to fasten the pulley to the tail piece timber. A screw-type porcelain insulator will serve as well as a pulley. To keep the wire lined up in the center of the pipes, it is necessary to drive a wooden plug guide into the pipe. A sewing thread spool may be found to serve as a satisfactory plug. The hole thru the plug or spool must be large enough for the wire to pass thru easily. Rubber tubing or electric wire loom may be used instead of the spools to insulate the wire from the pipe.

The put-out wire serves as one of the current carrying wires as well as supplying the means for shutting the plant off. Since the plant will turn with the wind, it is convenient to have a swivel in the pull-out wire to prevent it being twisted. A halter snap swivel, a tethering swivel or any similar device can be used. A light spring or small weight must be fastened to the lower end of the pull-out wire to keep it taut to prevent it kinking and touching the pipe.

The generator frame is connected to the floor flange bolts by a short piece of flexible wire. The same kind of wire as used for the pull-out may be used. The mast pipe then serves as one of the wires from the generator. By connecting an insulated wire from one of the pipe mast clamps, the circuit can be continued to the battery. A cutout is connected into the circuit as shown in Figure 2.

The pipe-mast mounting, tail-piece assembly and other minor details are the same as for Plant 1. To give the plant a finished appearance and to protect it from the elements, it should be given two or three coats of bright enamel.

LOCATING AND MOUNTING THE PLANT

The location of the wind plant will have considerable to do with the satisfaction obtained from it. The location ought to be 10 feet or more off the ground and in the open so the wind reaches the plant freely. Surrounding buildings or trees may necessitate mounting the plant high enough to allow the wind to exert its full effect on the impeller.

There are several ways of mounting the completed plant, depending upon where it is located and the height above the ground. The plan shows the 1¼-inch pipe rigidly clamped to a post. The plant may be mounted on the roof of a building, using a longer pipe and boring a hole thru the roof of the building. Another way would be to use a pole fastened along the wall and eave of the building. It is also possible to construct an angle iron tower which can be placed on the roof or ground.

Mounting the plant on a building may be satisfactory, altho the noise of the impeller is apt to be quite audible in the building. If mounted on a building, the wire from the frame of the generator should be grounded by a heavy wire with one end buried in the moist earth. This will insure some protection against lightning discharges.

MAKING THE IMPELLER

The building of an impeller for a wind electric plant is a relatively easy, altho a tedious task requiring patience. It will take about one day to make the first blade. The amateur building his first impeller should select a piece of soft, straight-grained board such as pine, free of knots, check cracks and pitch. Boards that are warped, twisted or contain pitch streaks should not be used. For a 5-foot impeller, the board should measure a full 5 feet long, 5½ inches wide, planed on one side and as near a full 1-inch thickness as can be obtained. Hardwood is hard to work but makes a better impeller. A very good impeller can be made of select birch.

Before making a blade, Table 3 should be consulted so as to get the correct dimensions for the blade to suit the generator that is being used. Most generators start charging at about 750 revolutions per minute. Therefore, a blade that runs about 750 revolutions per minute in a 15-mile-per-hour wind should be used.

The 1500-revolutions-per-minute blade will not start running as easily as the slower speed impellers. Its angle of attack is much less and therefore has less starting torque. This would mean that a generator equipped with the 1500-revolutions-per-minute blade may not start running in winds below possibly 15 miles per hour, unless the blade were started manually. In a wind stronger than 15 miles per hour, this blade would operate.

Table 3.—IMPELLER DIMENSIONS FOR DIFFERENT SPEEDS

| Revolutions per minute in 15 miles per hour wind | Thickness of Leading Edge of Blade | | | | Thickness of trailing edge before rounding off backside |
|--|---------------------------------------|---------------------------------------|---------------------------------------|--------------------------|---|
| | 12 inches from center (Point A) | 24 inches from center (Point B) | 30 inches from center (Point C) | 36 inches from center | |
| 750 | 3/4 inch | 3/8 inch | 1/4 inch | 7/32 inch | 1/8 inch |
| 1125 | 9/16 inch | 5/16 inch | 7/32 inch | 2/16 inch | 1/8 inch |
| 1500 | 7/16 inch | 1/4 inch | 3/16 inch | 5/32 inch | 1/8 inch |

Figured for a 50 percent wind slip on blade.

Will have starting difficulty in winds below 15 miles per hour.

Dimensions for end of a 6-foot blade.

A saw, square, sharp draw knife, plane, sharp straight edge for a scraper, a wood rasp and sandpaper will be about all the tools needed to make an impeller. For the last operations, the wood rasp, scraper and sandpaper will be found most convenient.

A small hole (such as a nail hole) should be drilled thru the center of the board. The remaining dimensions of the blade are measured from this center. **Mark a line along the back edge and front edge of the board as shown in the dimensions in Figure 2 and duplicate the blade drawing on the board. Be sure to mark the front and back edges off as shown in the sketch so the generator will run in the correct direction. Using a square, lay out the dimensions shown on the sketch.** Work the board down to the lines by using a draw knife and plane. This should be very carefully done as this is the way the angle of pitch of the blade is obtained. In case the blade is nicked or accidentally cut deeper than it should be, it is possible to build up these surfaces by filling in the pockets with powdered wood mixed with glue. After this hardens it can be sanded to a smooth surface. The powdered wood can be obtained by sanding the wood over a newspaper. Using a plane, the back side of the blade is rounded off as shown in the cross section views. For finishing the blade and giving it a smooth surface, use a wood rasp, scraper, and fine sandpaper. The ends of the impeller blade should be rounded off as shown and the blade tips should be tapered to a thin edge about one-eighth inch thick and rounded with a piece of sandpaper. The taper should start about 4 inches from the tip. Do not round off the leading edge of the blade as this will materially reduce its speed and power.

After the blade is finished, it should be balanced on its center by removing enough wood from the side that is heavier. A blade that is only slightly out of balance will vibrate excessively. After the blade is balanced, smoothed and sanded, it should be well covered with two coats of boiled linseed oil. It can then be painted with a good water resisting enamel. This will enable the blade to withstand the rain and sleet without warping for a longer time before it will need repainting.

FIGURING THE SHAPE OF THE BLADE

The correct pitch for the flat surface facing the wind at any point along the blade can be calculated by the simple arithmetic shown below. The smaller the pitch the faster the blade will revolve. If the blade is to run at 750 revolutions per minute in a 15-mile-per-hour wind with a 50 percent slip, it is evident that its pitch must be a changing value.

At a point on the blade 2 feet from the center, the blade must move 2 times 2 times 3.1416 which equals 12.57 feet in one revolution. If the blade revolves at 750 revolutions per minute, the 2-foot point moves 750×12.57 or 9428 feet per minute. If a 15-mile-per-hour wind produces this motion, it will have a velocity of 15×5280

————— or 1320 feet per minute. This gives a pitch ratio of
60

9428 to 1320 or about 7 to 1. Allowing for a 50 percent slip of the blade with respect to the wind, the slope will be 14 to 1.

The sketch of the blade has been laid out based on the above calculations so as to run 750 revolutions a minute in a 15-mile-per-hour wind. Actually this blade will run fast enough to make some generators charge in a 10-mile-per-hour wind. The back side of the blade is rounded with the same curves that are placed on the wings of airships. Since the leading edge is sharp and as the blade moves ahead, the air immediately in front of the blade must move faster than ordinarily in order to get out of the way of the impeller. This increased speed of the air causes a drop in pressure immediately in front of the blade. The effect is the same as a partial vacuum which causes the impeller to rush ahead still faster in an attempt to occupy this vacuum. Approximately 50 to 75 percent of the power of the blade comes from this suction on the back side. The power from this suction will increase quite rapidly with an increase in the speed of the blade, the ultimate limit being a force of suction equal to the atmospheric pressure of the air or 14 pounds per square inch of surface. About two-thirds of the back side has no slope. This allows a soft wood blade to have slightly more strength and rigidity. With soft wood such as pine this is desirable. If the blade at a point 2 feet from the center is $5\frac{1}{2}$ inches wide, the back edge of the blade must be $5\frac{1}{2}$ divided by 14 or 0.39 inches or about three-eighths inch lower than the front edge of the blade.

A point on the blade 1 foot from the center of the impeller will have a tangential velocity just one-half as fast as at a point 2 feet from the center. The pitch at a point 1 foot from the center will need to be just twice as great or about $\frac{3}{4}$ inch lower at the back edge as compared to the front edge. At a point 8 inches from the center the pitch must be three times as steep as at the 2 foot point from the center as its tangential velocity is one-third as great.

The reason for using considerable care in making these pitches correct is to insure that all sections of the blade will tend to turn at the same relative revolutions per minute. If the front side of the blade does not have a graduate pitch but has one single flat pitch, the blade will not run smoothly and will not develop the correct amount of power from the wind. The blade will make considerable wind noise and may vibrate quite excessively.

If it is desired to build a higher speed blade, the angle of pitch can be made less than that given in the plan and described in this publication. Since the average generator starts charging at a speed of about 600 to 800 revolutions per minute, the above described blade will be found to be satisfactory for direct drive. At the same time its speed in a heavy wind will not be so high as to wreck the blade.

MOUNTING THE IMPELLER ON THE GENERATOR

The blade can be mounted on a generator for direct drive. In case the generator comes equipped with a V-pulley, four holes can be drilled thru the rim of the pulley. Holes can also be bored in the impeller to match those in the pulley. Special care must be taken, however, to see that the center of the pulley matches the center of the impeller before the holes are bored thru the impeller. Stove bolts one-fourth inch by 1¼ inch will be about the correct size. If the hub of the pulley protrudes too far, a hole must be bored into the impeller to allow for this extension of the pulley hub. The inside of the holes bored into the impeller should be well saturated with linseed oil to keep out moisture. The use of a direct drive is superior to a belted arrangement, as this arrangement eliminates the use of belts, extra bearings and the mechanical troubles that accompany their use.

SELECTING A GENERATOR

The question of selecting a generator is a bit difficult to answer. Some of the makes of generators that make good wind driven generators are Delco-Remy, Auto-Lite, Ford Models for A or V-8, and others. Ford Model T generators are quite high speed and are not satisfactory unless geared up or rewound.

In determining the suitability of a generator for a wind driven plant, the best procedure is to connect the generator across a 6-volt battery and run the generator as a motor. If it runs satisfactorily without smoking, in most cases it will work as a generator. Do not attempt to run the generator for any length of time as a motor.

The front bearing of the generator must be in good condition so the parts stay in position. The impeller blade may exert a thrust on a loose bearing that may soon cause difficulty. Generators having ball bearings will run easier than bronze brushings. There must be some provision for oiling the bearing, and dust and dirt must be kept out of it.

REWINDING GENERATORS

There is not much to be gained in rewinding an automobile generator for slower speed, as the cost is relatively high and the current output is decreased. There are electric shops equipped to do rewinding work, and quotations should be received from them for the type of generator at hand. Some concerns sell various kinds of "kits" for generator changes. The local electrician, radio shop, or garage can often give information on rewinding generators.

Since some folks may wish to rewind their generators for slower speed, the following suggestions are given. When a generator is rewound for slower speed, smaller wire must be used as more turns are wound on the armature. This very definitely limits the maximum charging current available from the generator by exactly the same amount as the size of the new wire compares to the original wire. Also, it is a rather tedious and difficult task to rewind a 6-volt armature unless one has the proper equipment and experience to do the job. By the time one pays for the magnet wire and has to rewind the machine several times before the job is satisfactory, it is usually cheaper to buy a generator that will work as a charger.

A 12-volt generator may be rewound into a 32-volt generator. Before spending too much money or time on this, it is best to check the generator over to find the condition of the bearings and commutator. If the machine is a 4-pole type, it should have at least 40 commutator bars if it is to commutate 32 volts without sparking or overheating of the armature. There are firms in the larger towns, and sometimes in other places, who have facilities for rebuilding 12-volt generators into 32-volt machines. The fields in these generators also need rewinding. The total cost of the job, including new bearings, new commutator, and other parts will be about \$20 to \$25.

WIRING FOR THE PLANT

In wiring the plant the use of too small a wire is unsatisfactory as there is too much of a voltage drop in the wires to the battery. All wiring should be with No. 10 or No. 12 gage insulated copper electric light wire, such as is used in wiring houses for regular electric light service. Steel wire should not be used as its resistance is too great. The battery should not be over 75 feet from the generator.

Regular house wiring fixtures are necessary in wiring any buildings in order that one may avoid insurance difficulties. The wires should enter the building thru porcelain tubes instead of thru holes bored thru the walls or window sills. Porcelain knobs or blocks are satisfactory to hold the wire away from the wood of the building.

There is one precaution to be observed with this machine. The generator should always be connected to its battery load, using care to see that all connections are bright and clean. Failure to do this may result in a burned out generator. If the battery is removed, the generator must be short circuited by connecting together the two lead wires from the generator to the battery.

The cutout may be mounted near the batteries along with an automobile ammeter. The connection of these instruments is shown on the plan.

The battery will need to be located in a place where there is no danger of freezing. This is important as the battery will not always be up in its charge as will occur when used during calm weather. When the battery is used for lights, it must be located close to the lights, otherwise too much current will be lost in the wires.

A hydrometer will be convenient for checking on the condition of charge of a battery:

| Reading of hydrometer | Condition of battery | Freezing point. Fahrenheit |
|-----------------------|----------------------|-------------------------------|
| 1.280-1.300 | Full charge | |
| 1.250 | ¼ discharged | 60° below 0 |
| 1.215 | ½ discharged | 20° below 0 |
| 1.180 | ¾ discharged | 0° |
| 1.150 | Discharged | 20° above 0 |

If the batteries are in a discharged condition, and are left in that condition for a period of time, the plates will sulphate. For best results keep the battery charged, but do not let the battery remain for any time with a test lower than 1225. During periods when the lights are not used, the plant should be run occasionally rather than be shut down for a long period of time.

When the distilled water in the battery is low, additional distilled water ought to be added when the plant is charging so as not to leave the solution in the top of the cells in a diluted form that can be easily frozen. Inspect the battery at least once each week, and test its charge condition and add distilled water to cover the plates whenever necessary.

In wiring the house for lights it is suggested that one use size No. 10 wire and regular light fixtures. One can buy 6-volt lamps in 5, 10, 15, 25 and 50-watt ratings with the 15, 25, and 50-watt sizes most common. These lamps are the same size as the regular lamps used on 110 volts, except that the filaments are much heavier.

Attach all light connections to the battery terminals rather than to the generator lead-in wires. This will give less voltage variation on the lamps when the generator may be charging the battery while the lights are on. Thirty-ampere fuses should be placed in the line leading to the lights from the batteries.

Fire insurance regulations are quite specific in their requirements for house wiring.* The use of 6 volts for the voltage supply does not excuse one from the obligations of following these regulations if a fire from defective wiring is to be avoided. This means one ought to use standard approved electric light fixtures and supplies.

Some of these regulations and other suggested precautions are:

1. Always solder all electrical wire splices, using rosin core solder. Wrap the splice with rubber tape and friction tape. Always insist on tight screw terminal connections where any such connections are used.

2. Never use acid core solder as the acid will soon corrode the electric wires and fixtures.

3. Use no wire smaller than a No. 12 gage rubber covered copper wire. A No. 10 gage is even better as it will carry the current with less loss.

4. Do not wire up the house unless done with knobs and porcelain tubes or other approved wiring fixtures. Do not staple the wire to the beams or rafters as this does not provide good insulation and may lead to short circuits and fires.

5. Never connect a lamp load to the generator when the battery is disconnected. To do so is almost certain to lead to burned-out lamps and possible damage to the generator.

6. Be sure one lead from the generator is grounded by connecting a wire to the generator frame and fastening the other end of the wire to a one-half-inch galvanized pipe which is driven into the ground to a depth of 2 feet or more into moist earth. This will give a certain amount of protection against lightning discharges harming the generator.

7. In case the battery is removed for any reason, be sure to fasten the two wires from the generator together. This will prevent the generator from burning out in a heavy wind.

8. The coils of wires from the generator and the lead wires should be arranged so they can never get into the impeller. Such an accident is almost certain to ruin the impeller.

9. Never mount the generator so close to the ground as to allow the blade tip to be in reach of one's head. At the high speed which the blade runs, it is possible for the blade to cause serious injury to a person.

10. Do not expect satisfactory results if the generator is mounted near trees and large buildings which will obstruct the wind from reaching the impeller.

*It is suggested that a wiring instruction book be secured.

CHARGING 2-VOLT BATTERIES WITH 6-VOLT GENERATOR

A 6-volt wind charger can be used to charge a 2-volt wet cell battery. It is necessary to place a resistor in the wire going to the battery to dispose of the excess current. These resistors are sold by most mail order houses, or they can be obtained from the local radio dealer.

A 6-volt battery has 2-volts per cell. By connecting to one cell, 2-volts can be had for the radio. Of course, one should not use the current continuously from one cell, but should change from one cell to another every week or 10 days.

Never connect a 2-volt radio across all three cells or even two cells of a battery. To do so would burn out the filaments of the radio tubes.

THINGS TO LOOK FOR IN CASE THE PLANT FAILS TO CHARGE

1. The blade may not be running fast enough to bring the generator up to charging speed caused by

- (a) Too low a wind velocity.
- (b) Faulty impeller construction, such as making the angle of attack too steep or shaping the back side incorrectly.
- (c) Using a high speed generator, such as a Model T Ford generator, with a low speed blade.

2. Some of the wiring connections between the battery and generator may be loose. Careful inspection should be made and any wire connections made with screws should be tight, and all wire splices soldered and taped.

3. Commutator may be dirty or glazed so the brushes do not make good contact with the commutator. Polishing the commutator with fine sandpaper will remedy this condition. **Do not use emery cloth** as the emery particles imbed themselves in the copper bars and will wear the brushes away quite rapidly.

4. The third brush of the generator may not be advanced far enough to enable the generator to charge.

5. The battery posts may be corroded or sulphated. If such is the case, they should be cleaned thoroly and then covered with a coating of vaseline or cup grease.

6. The battery may be unable to hold a charge because it is defective or is old and worn. Old discarded auto batteries are not as a rule desirable for wind plants.

7. The hot wire from the generator terminal post may be grounded on the pipe frame or on the generator frame. This is equivalent to short circuiting the generator and will prevent the generator from charging under any condition.

8. The battery cells may need distilled water to cover the plates.

9. Some of the cells of the battery may be shorted so the battery voltage is less than 6 volts. The individual cells of each battery can be checked by shorting the cell temporarily with a short piece of wire. A cell that is no good will give out very little short circuit current. An even better way to check this is with a hydrometer.

10. The cutout may be defective or shorted within itself. Such a condition does not happen very often.

11. The generator may be burned out as a result of not being always connected to the battery load. This can be checked by inspecting the armature winding to see if the winding is charred.

32-VOLT GENERATORS

At times, an individual has a 32-volt generator, or knows where there is one available, and considers such a generator for an electric plant. It is important to determine if the generator is designed to run at a uniform speed or can run at variable speeds. Wind drives are variable speed and constant speed generators do not work satisfactorily with such drives. It is necessary to use a gasoline motor to drive a constant speed generator. Automobile generators differ from light plant generators in that the car generator is designed to operate at variable speeds. This is the reason that car generators make satisfactory wind plants.

Most impellers for 32-volt wind-driven plants are single blades 8 feet long. It is easier to make a single blade impeller than one of three or four blades. Large blades are hard to make and balance and it may be more desirable to purchase one for a 32-volt plant. In case a blade is made for a 32-volt plant, follow the same arithmetic method for speeds as given for 6-volt plants.

Five or six 6-volt automobile batteries can be used to store current from a 32-volt generator if the batteries are connected in series, that is by connecting the positive terminal of one battery to the negative terminal of another battery.