

**AT** MICROFICHE  
REFERENCE  
LIBRARY

A project of Volunteers in Asia

Wood Conserving Cook Stoves: A Design Guide

Published by:

Volunteers in Technical Assistance  
1815 North Lynn St. Suite 200  
P.O. Box 12438  
Arlington, VA 22209 USA

Paper copies are \$ 8.95.

Available from:

Volunteers in Technical Assistance  
1815 North Lynn St. Suite 200  
P.O. Box 12438  
Arlington, VA 22209 USA

Reproduced by permission of Volunteers in  
Technical Assistance.

Reproduction of this microfiche document in any  
form is subject to the same restrictions as those  
of the original document.



# **WOOD CONSERVING COOK STOVES**

**A Design Guide**

**A VITA/ITDG PUBLICATION**

Front cover: "The Wood Gatherer,"  
an original woodcut by VITA  
Volunteer Rosemary Feit Covey.  
Available in a limited edition of  
signed prints on Japanese rice  
paper. \$25.00 (US) each plus  
\$2.00 (US) postage and handling.  
Proceeds from the sale will sup-  
port VITA's publication efforts.

ISBN 0-86619-000-7

© 1980 Volunteers in Technical Assistance

# **WOOD CONSERVING COOK STOVES**

**A Design Guide**

**Funded by  
Al Dir'iyyah Institute  
Geneva, Switzerland**

**Published by  
Volunteers in Technical Assistance  
3706 Rhode Island Avenue  
Mt. Rainier, Maryland 20822 USA**

**WOOD CONSERVING COOK STOVES, A Design Guide,** promotes stoves and cooking methods that are inexpensive, culturally acceptable, and environmentally sound. It is meant especially for field or extension workers, and is aimed at engineers, end users, and all those interested in wood stove design and use.

Enough information is contained in the manual for the reader to:

- . choose an appropriate stove
- . understand how wood burns
- . know what makes a stove more efficient
- . construct four stoves

All of this information is provided to support local stove efforts and expand the dialogue among stove builders. Readers are urged to use the bound-in reply form to share their experiences.

A second volume of this book is planned. It will focus on how to introduce stoves through small-scale local programs, taking into account the social and cultural aspects of stove design. It will also include information on testing stoves.

# Contents

Acknowledgements.....	vii
Introduction .....	1
1. HOW TO USE THIS BOOK .....	7
2. HOW STOVES WORK .....	9
How wood burns .....	9
How heat is transferred .....	12
Conduction	
Radiation	
Convection	
How heat is contained .....	15
Stove components	
Traditional stoves	
Simple metal stoves	
3. HOW TO MAKE STOVES EFFICIENT .....	29
Conserving heat .....	29
Energy losses in stoves	
Improving combustion efficiency	
Using the heat from the gas stream	
Minimizing heat loss from heating the stove	
Minimizing heat losses from pots and stove walls	
Improving traditional stoves .....	33
Combustion chamber engineering	
The chimney-and-damper approach	
Improving combustion efficiency	
Improving stove building materials .....	47
Cast iron, steel plate and sheet metal	
Ceramic	
Mud and brick	

4. HOW TO BUILD FOUR STOVES .....	55
Lorena stove .....	55
Materials	
Tools and equipment	
Construction	
Use of the stove	
Smokeless chula .....	71
Materials	
Construction	
Use of the stove	
Singer stove .....	83
Materials	
Construction	
Use of the stove	
Sawdust cook stove .....	94
Materials	
Tools and equipment	
Construction	
Use of the stove	
5. HOW TO USE STOVES EFFICIENTLY .....	99
Choosing wood .....	99
Using wood .....	102
Dictionary of Terms .....	105
Bibliography .....	109

# Acknowledgements

This manual has been made possible by a grant from the al Dir'iyah Institute of Arlington, Virginia, and Geneva, Switzerland.

No manual like this is produced without the work of many hands. Special thanks go to Kristine Stroad Ament, and to Stephen Joseph of the Intermediate Technology Development Group for editing, to William Gensell and Michael Boutette for illustrating, to Bonnie Duley for layout, and to E. Christopher Cone for typesetting. Past and present VITA staff researchers, writers, and editors include Margaret Crouch, Laurel Druben, Gregory A. James, David Jarmul, Alice Manker, and William Magrath.

VITA volunteers and others who reviewed the book for technical accuracy include Nancy Axinn, Dr. Norman Brown, Dr. Gautam Dutt, David Hughart, Dr. Larry Icerman, and Jeff Wartluft.

Volunteers in Technical Assistance  
June 1980



# Introduction

The costs of using firewood in traditional ways are growing every day. Fuelwood is the primary source of energy for households in developing countries (Openshaw, 1974). It is used mainly for domestic cooking and, to a lesser extent, for heating and industry.

Population pressure in many areas has made the demand for firewood consistently exceed the supply. The consumption of wood in Nepal is seven times greater than the annual forest yield. The price of firewood in Kathmandu has tripled in three years (Karki and Coburn, 1977).

The "cost" of gathering firewood in India has been found to be between 200 and 300 person-days per family per year--a full-time job for one person. It is common in sub-Saharan Africa to travel by foot or animal-drawn cart more than 50km (30 miles) for firewood. Firewood can cost as much as one-quarter of the family's income in areas where it is purchased.

The soil deteriorates and retains less water as timber resources are depleted. This leads to desertification in some areas and to severe flooding in others. Most poor people in Third World countries are 'energy-gatherers' (Reddy, 1976). They cannot afford to buy fossil fuels. They have no alternative, such as biomass fuels. Fuel for cooking is a necessity. Even if such people are aware of a conflict between short- and long-term interests, they are too poor to postpone their immediate needs for such long-term gains as maintaining soil fertility.

For the cook and the cook's family, the problems do not end once the firewood is gotten. Smoke from open fires and inefficient stoves can create a dirty, unhealthy situation. Eye and respiratory problems are wide-spread. Burns and scalds--

especially with children--are numerous. Flying sparks create a constant fire hazard. Even without these serious dangers, a smoke-filled, soot-blackened cooking area is neither a pleasant nor healthy place in which to work.

On a wider scale, the problems caused by deforestation are not hard to see--when one has the time and opportunity to view them from a broad perspective. However, wood usage problems remain far more personal for most users. Most families must adjust to increased demand as wood becomes ever harder to find.

It is likely that wood and other biomass fuels will be primary fuels for these people for some time. Such alternatives as solar cookers and methane digesters are more likely to be used in small-scale industrial processing than in homes.

The wood fuel shortage must be attacked on several fronts simultaneously to meet the growing ecological crisis. Resources must be conserved through comprehensive reforestation programs and well-managed village wood-lots (Earl, 1975; Openshaw, 1973).

Many proposed solutions have a long-range focus. Few seek to change current patterns of use. But the only immediate hope is to reduce end usage. Even a 10 or 20 percent reduction in the use of firewood can have significant results. The demand for firewood can be reduced by designing and introducing stoves that are efficient, cheap, and culturally acceptable.

Despite the fact that a number of efforts are underway to develop wood-conserving cook stoves, little effort has been made to draw the results together and look at them in terms of their similarities and differences. Even less has been done to teach principles of stove design. This knowledge is essential for stove building efforts. A review of the state-of-the-art suggests that while different in appearance and construction materials, improved wood cook stoves are all based on the same design principles.

The information available on wood cook stoves is scattered and sometimes too oriented to research. Existing materials may be

hard to read or do not aim at getting stove technology into the hands of local users.

The reason for the lack of data seems to be that planners have for years assumed that people advanced from wood fires to an electric or gas range, not to an improved wood-burning cook stove. It just was not considered necessary to think very hard about a better cooking system based on wood usage.

Two major world forces today require more work to be done in the wood stove area. One force is provided by the more developed countries as they seek alternatives to a heavy and expensive dependency on gas and electricity, particularly on a personal-use level. At the same time, it has become almost impossible in some less developed countries to find wood. Gas and electricity are either unavailable or too expensive.

It should be noted clearly that the reason for moving from wood stoves to cooking systems based on other power sources--in the areas where this has occurred over time--was that these other sources became more feasible. They were efficient, clean, seemingly abundant, and cheap. Today, the state of the world suggests that wood-burning systems, at least improved ones, are a more attractive alternative for some applications than was once thought. The interest in many developed countries is in wood stoves for space heating. The emphasis in less industrialized countries is on improved cooking stoves, the subject of this manual.

Based on the data collected during a search of worldwide literature and in consultation with a number of experts, VITA chose a small number of wood conserving stove technologies to be highlighted in this manual. The technologies were chosen on the basis of (1) the way in which the stove incorporates design principles and shows the adaptation of a basic design to meet local situations, and (2) its ability to serve as a model for both technology adaptation and introduction. In other words, one of the key criteria is that the technology can be taken successfully from the workshop into the marketplace.

Perhaps the most basic design comes from India, where much work with cook stoves was started with the interest of Mohandis Gandhi in programs for rural areas. The major research result in India has been the Hyderabad Engineering Research Laboratory chula, better known today as the HERL chula. Chula (also spelled "chulah") simply means cooking place. The HERL chula was based on traditional Indian fireplaces, and adapted by S.P. Raju, former director of the Laboratory. Many stove designs being promoted throughout the world today are based on the HERL chula.

A description of the HERL chula provides a good overview of improved stoves. The HERL chula is basically a block of clay and sand. A tunnel runs horizontally through it. Holes to fit the cooking vessels are cut through the top of the block. The fire is built at one end of the tunnel beneath the first pot. A chimney of clay or sheet metal is installed at the other end. Hot gases and flames flow within the chula through the tunnel, under the pots, and up the chimney. A damper provides draft control. The number of pots and the size and height of the stove can be adjusted to the user's preferences. Because it forms the basis for so many other stoves, a modification of the HERL, the smokeless chula, is presented in **4. HOW TO BUILD FOUR STOVES.**

Complete descriptions of two adaptations of the HERL chula have also been included: the Lorena stove and the Singer stove. While both stoves rely on the same basic design elements--a tunnel carrying hot gases under and around pots held above--the stoves provide models of how the basic chula has been adapted to local cooking preferences and to available building materials.

The Lorena stove is built from a massive sand and clay block, while the Singer stove is assembled from smaller blocks. The description of the Lorena stove begins on page 55. The description of the Singer stove begins on page 83.

In addition to the modified chulas, other stoves have been designed for burning other organic fuels--such as sawdust or rice hulls. (A description of a sawdust cook stove begins on

page 94.) The practice is not new. Such materials have been used for some time. In Upper Volta, for example, millet stalks are burned almost exclusively for six months of the year. Wood is used the rest of the time. In south Asia, cakes of cattle dung are used as a fuel supplement.

The use and availability of alternative fuels affect the type of stove that can or should be constructed. Slight changes in the design of a stove can make it adaptable for burning wood and alternative fuels. Again, the process depends upon understanding the design criteria. This manual includes several suggestions for wood-conserving stoves that can be used to burn alternative fuels.

While most improved cooking systems depend upon relatively large stationary stoves, this guide also includes some suggestions for making relatively small, portable stoves from 20-liter (5-gallon) metal containers. These stoves have definite advantages in areas where the population is mobile or for city-dwellers who must cook outside for reasons of space and health.

The less portable stoves highlighted in this manual can be built to any height desired. Cooks in some cultures squat while cooking their food. In other cultures they stand. A lower stove requires less materials to build, but a stove that is about waist high is very convenient to use and is safer if small children are present. Of course the size and number of pot holes can be varied as well.

Even with technical considerations, the stove designer must carefully examine the range of functions served by a traditional stove. For example, a stove with a chimney to provide draft is more efficient than a stove lacking a chimney. However, people in Bangladesh do not regard chimneys as desirable because they need to keep stormwater out during monsoon rains. Smokeless stoves have also proved unacceptable in many places because people depend on smoky fires to keep thatched roofs dry and insect-free. Roofs do not last as long with a smokeless stove. Both of these examples illustrate how

designers can be misled if they consider only those technical functions of stoves with which they are familiar from their own cultures.

# 1. HOW TO USE THIS BOOK

This book explains what fire is, and then discusses the various ways in which fire is enclosed. The material is based on information from VITA's Documentation Center, and on the experiences of wood stove experts and users. This manual requires no special technical skills.

Each section is carefully designed to provide information to help readers build the stove most useful to their needs. The chapters are as follows:

**2. HOW STOVES WORK** explains in a simple way what fire and heat are, and describes basic stoves and their components.

**3. HOW TO MAKE STOVES EFFICIENT** discusses the ways in which stoves can be made to conserve heat, including design principles, improvements on traditional stoves, and better building materials.

**4. HOW TO BUILD FOUR STOVES** gives design, construction, use, and maintenance information for the Lorena, smokeless chula, Singer, and sawdust cook stoves.

**5. HOW TO USE STOVES EFFICIENTLY** outlines the characteristics of wood as fuel.

**A DICTIONARY OF TERMS** gives clear definitions for many technical terms used in the book.

**A USER'S QUESTIONNAIRE** is bound into the back of the book. This evaluation form is to be filled out and returned to VITA by users of the manual. The information will be used to revise and update future editions.

## 2. HOW STOVES WORK

Fire is so important to human health and comfort that for many years the Greeks and others thought it to be one of the basic elements of the universe. We now know that fire comes from a source of heat applied to fuel in the presence of air.

### How wood burns

Air is made of gases, mainly oxygen ( $O_2$ ) and nitrogen ( $N_2$ ). Heat sources can be the sun, its rays focused on the wood, or the flame from a match or flint. The fuel in this case is wood. Wood is made mostly of cellulose, lignin, water ( $H_2O$ ), resin, and other materials. Wood is an organic substance; it once was a living thing.

When heat is applied, the surface layer of the wood gives off water, carbon dioxide ( $CO_2$ ), and some organic acids (see Figure 1). The carbon dioxide and the water vapor cover the surface of the wood and prevent oxygen from coming into contact with the wood. This results in smoke but no flame.

As the temperature rises, the surface of the wood chars (burns into charcoal). At the same time, heat is sent inward through the wood. This causes water to be freed from the inner part of the wood. Then gases and tar are freed. They spread over the surface of the wood. The tar reacts with the char to form volatile gases. These produce a flame, in the presence of oxygen. The flame gives out heat.

Each gas requires a certain amount of air and must reach a certain temperature before it will ignite. The greater the amount of air, the more heat the gases will carry away. But the wood will not ignite if the proportion of excess air exceeds a certain limit. In this case, there are too few chemical reactions



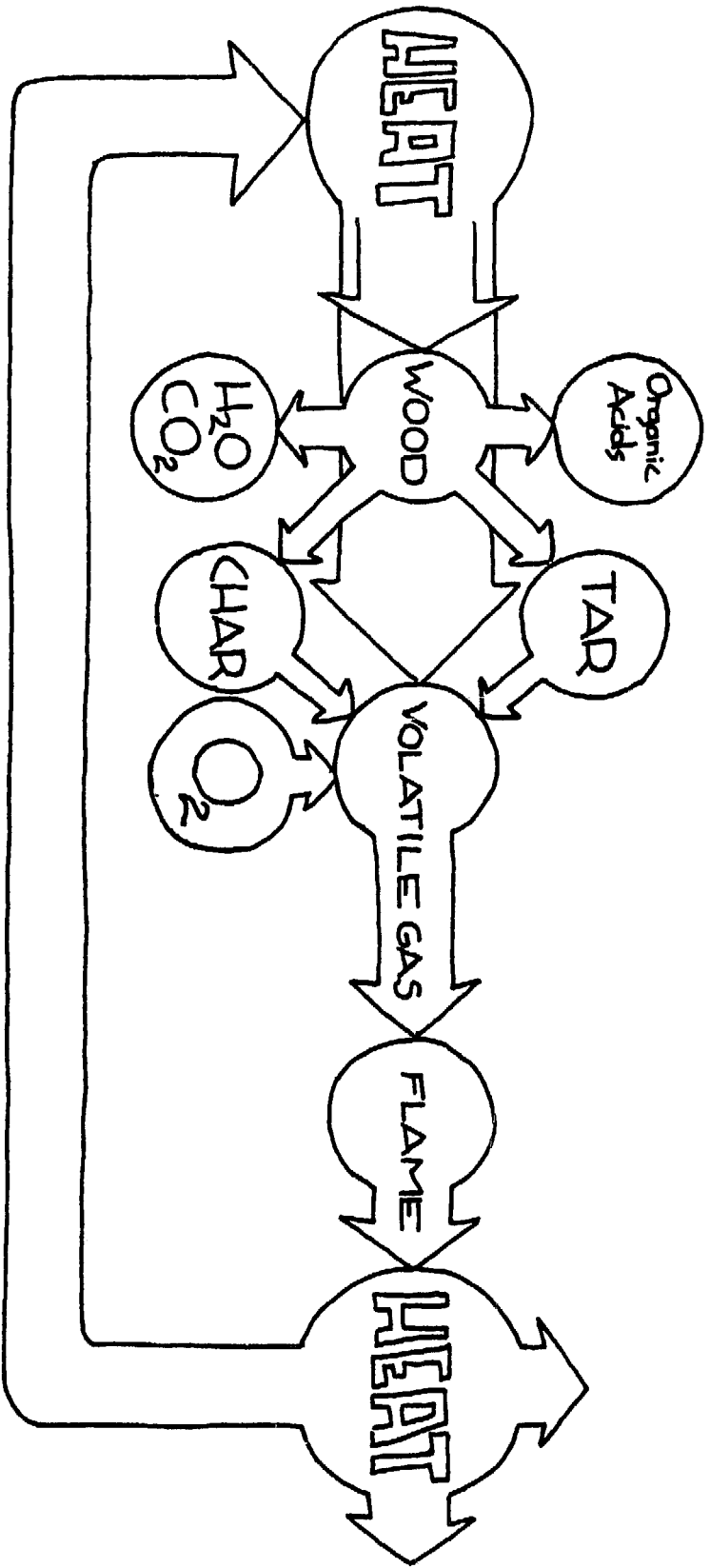

MB

Figure 1

to generate the heat necessary to compensate for the loss of heat from the reaction area. This also occurs when there is not enough air present.

Once ignited, the gases burn with a luminous flame. The heat continues to drive more gases from the wood until only carbon monoxide and hydrogen are given out. The charcoal merely glows with little or no flame.

An average of 30 percent of the radiation energy (see next section) is reabsorbed by the wood. This helps maintain the burning process.

The various reactions of the oxygen in the incoming air can be summarized as follows:

<u>Substances Which React</u>	<u>Where the Reaction Occurs</u>	<u>Products</u>
Char + air	fuel surface ----->	carbon monoxide, carbon dioxide
Tar + air	flame ----->	carbon monoxide, carbon dioxide,
Gas + air	flame ----->	and water

The main combustion products are carbon dioxide, carbon monoxide, water, and soot (carbon).

When the burning process goes quickly, a lot of tar and highly flammable gases are produced and a lot of heat is freed quickly. Little charcoal is produced in that case. If burning is slow (for example, if there is little air and little heat near the wood surface), then more carbon dioxide, water vapor, and charcoal are produced. Heat is given out at a much slower, more constant rate.

## **How heat is transferred**

Heat is transferred in three ways: by conduction, by radiation, and by convection. Heat is transferred within the wood by conduction, from the flame to the wood by radiation, and from the hot gases to the wood by convection (see Figure 2).

### **Conduction**

Conduction is the passage of heat through a substance, from a hot area to a cold area. If one end of a substance is heated, that hot end contains more energy than the cold end. This energy difference is transferred through the material via the motion of the atoms in the substance.

Some materials do not conduct heat very well. These materials are called insulators. Wood, air, and very porous clay bricks are relatively poor conductors of heat.

Thus a brick stove, which is a poor conductor, will take a much longer time to heat up than a steel stove, which is a good conductor of heat. The rate at which heat is transferred through a material depends on: (1) the temperature difference, (2) the area that is being heated and cooled, (3) the ability of the material to conduct heat, and (4) the thickness of the material.

### **Radiation**

All bodies above absolute zero temperature give off energy in the form of heat radiation. When heat radiation comes into contact with a solid, it is reflected, absorbed, or transmitted to the solid.

A body gives off radiation over a range of wavelengths, and reaches a peak intensity at a particular wavelength for a given temperature. Radiation is given off at low temperatures mainly

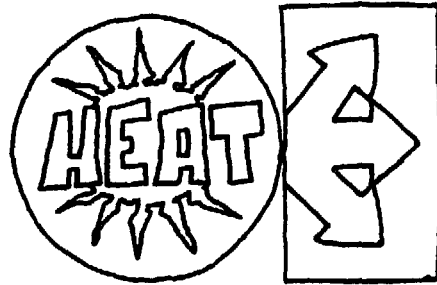

Conduction

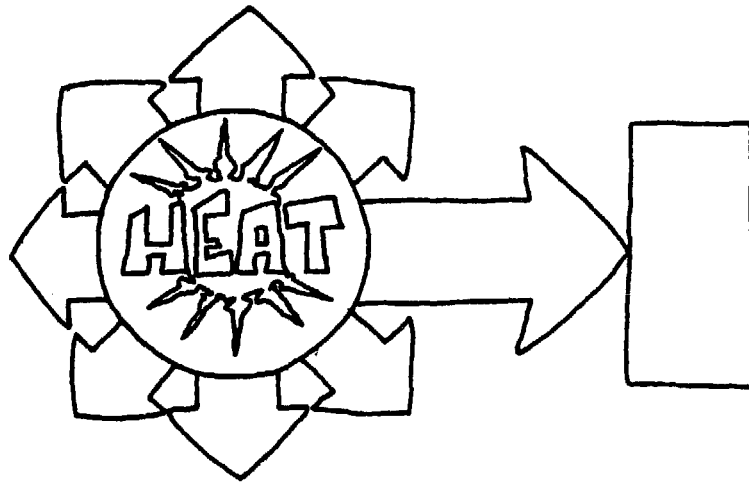

Radiation

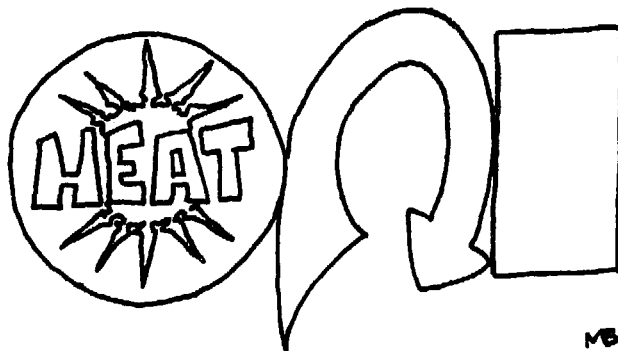

Convection

Figure 2

in the infrared spectrum. It is therefore not visible. As the temperature increases, more and more of the radiation is given off at wavelengths in the visible spectrum. Thus, while we cannot see the heat radiation from a hot cooking pot and may burn ourselves if we touch it, we can see bricks glowing in a kiln. The amount of radiation received from a surface that is giving off radiation decreases rapidly with distance from the source.

Wood gives out a luminous, yellow flame when it burns. The power to radiate heat is very high in luminous flames because the flame consists mainly of burning black carbon particles. Burning carbon gives out a brighter light than burning gases. As the number of carbon particles being given off decreases, so does the flame's power to give off heat. The blue flame given off by burning charcoal has a much lower ability to give off heat radiation than does the yellow flame of burning wood. Hot wood also radiates heat, as do the walls of the combustion chamber. Each piece of cold wood absorbs radiation from any surface of a higher temperature--from the combustion chamber walls, from the flame, and from other pieces of wood. The outer surface of the walls will also give off radiation to the outside.

Radiation is by far the most common way in which heat is transferred within a fire chamber.

## **Convection**

Convection involves the transport of heat by the movement of some sort of fluid, such as air or water.

Air in a room heated from the radiation of a fire moves upward. Colder, heavier, denser air moves in to take its place. In this case, the hot air has moved only because of its own natural buoyancy. The hot air is lighter and less dense than the cold air. This type of heat transfer is called natural convection. It is this buoyancy effect that causes heated air to leave a stove or fireplace. Buoyancy also permits colder air to enter and supply the oxygen needed for combustion.

On the other hand, if air is forced into a fireplace by the wind or a blower, heat is transferred by forced convection or advection. This also accounts for the large loss of heat from a pot sitting on an open fire on a windy day. Even though wind is a natural phenomenon, the convection produced by wind is called "forced" convection because it is not induced by buoyancy.

Note: For a discussion of the characteristics of wood, including factors which affect the efficiency of wood combustion, see 5. **HOW TO USE STOVES EFFICIENTLY.**

## **How heat is contained**

The simple act of enclosing a fire and thus controlling the amount of air fed into it greatly affects the intensity of the heat and the efficiency of the burning process. A cooking fire that is enclosed in some way becomes a stove.

### **Stove components**

The most basic wood-burning cook stove is an open fire circled by a few rocks or by bits of brick. A pot is balanced on the rocks. This basic stove is unsatisfactory for the following reasons:

- . It is very wasteful of fuel.
- . The temperature is difficult to regulate.
- . Smoke from the fire can cause or worsen eye and respiratory problems, and can leave cooking areas black with soot.
- . Burns and scalds are a danger, especially for babies and small children.

In some areas, the efficiency of this type of fire has been increased greatly by simply building walls almost completely

around the fire. The top is covered with some kind of grating upon which the pot is placed. While this does not help a great deal with the smoke problem, it can result in substantial fuel savings.

Adding a flue or chimney (described below) and a draft control further increases fuel efficiency, helps in temperature control, and stops much of the smoke problem. An improved cook stove can be made from a variety of designs, using many different types of materials. Fired bricks, sun-dried clay blocks, clay/sand mixtures, and sheet metal have all been used to make improved cook stoves (see **Improving Traditional Stoves**, which follows this section).

Several basic components are common to all improved stoves:

- . firebox
- . flue or chimney
- . air inlet
- . one or more dampers
- . baffles
- . heat exchangers

### Firebox

The chamber in which the initial combustion takes place and the fuel is burned is the firebox. Some stoves may also contain a secondary firebox where many of the gases produced by the initial combustion are burned. There should be no uncontrolled points of entry for air in the firebox.

### Chimney or Flue

The chimney, or flue, is the passage by which the gases and smoke leave the fire. The function of the chimney is to draw water vapor and smoke out of the kitchen and to create a pressure difference so that air is drawn into the firebox. The words "chimney" and "flue" are often used interchangeably. Some

people interpret "flue" to mean only the passageway between the firebox and the chimney. To others, the "flue" is the passageway in the chimney.

The chimney commonly extends upward from the stove a distance of 1-3/4 to 2-1/2m (6' to 8')--or more. This distance varies with the type of stove and can best be determined by experimentation. Some stoves simply will not burn well until a certain chimney height is reached. To find the best height, one can either start small and add sections, or start tall and take away sections. The top of the chimney should be about 3/4m (30") above the highest point of the roof. This is for both safety and preventing downdrafts from forcing smoke back into the stove. Downdrafts sometimes occur around buildings.

The diameter of the chimney is also variable. There are equations that can be worked out taking into account the size of the firebox, height of the flue, etc. But in a practical situation, chimney diameter will probably be determined by what is available at the lowest cost. Often this will be 10cm (4") galvanized stovepipe. For the range of designs presented in this manual, that size pipe is perfectly adequate.

The chimney should have a cap on it to prevent rainwater from washing into the stove. It may also require a spark guard--a little screen cage--to prevent sparks from flying out onto flammable roofing material. Both cap and guard should be removable to permit easy cleaning of the chimney. This is very important.

The chimney must be cleaned regularly. As the hot gases and vapors cool, some substances condense and collect on the inside of the flue. One of those condensates is creosote, a dark, sticky, very flammable material. A heavy buildup of creosote can clog the chimney. Worse, it can catch fire from a flying spark. Creosote deposits can be burned off in the early stages by building a very hot fire in the stove. Or they can be removed by cleaning the chimney at least every six months. This can be done with a long-handled brush, or with a bundle of sticks and rags attached to a long pole.



A metal chimney will lose heat faster, and thus be more prone to a creosote buildup than will a clay or masonry chimney. Galvanized metal is preferred over blued metal by some people. In some places, work has been done with a material that might be called "ferromud"--a form made of chicken wire, plastered with clay to form a strong chimney. "Ferromud" may be significantly cheaper than either metal or clay chimney pipe.

### Air Inlet

The fuel must have oxygen to burn. Air is fed into the firebox through an air inlet and then sucked through the fuel by the draft created by the flue or chimney. Because a strong draft causes a hot fire, an efficient stove will have an adjustable opening to allow the cook to control the rate of burning, and thus to control the temperature.

### Dampers

A damper is a movable plate which controls the draft. One or more dampers can be used to control the flow of air. Placement and operation of the dampers depend on the design and construction material of the stove. If only one damper is used or needed, it should be placed at the mouth of the air inlet. A second damper can be placed at the end of the stove portion of the flue, just before it bends upward. Sometimes sections of commercial stovepipe are available which have dampers built in. A very large stove may require additional dampers to prevent the hot gases from reaching unused areas of the stove.

The damper can be made of metal or blocks of clay or stone. It must fit very snugly so that it can block the flow of air completely. Sheet metal especially will be hot to the touch, so some kind of relatively cool handle should be provided.

### Baffle

In a chula-type stove, like most of the ones in this manual, a baffle is a mound or step molded into the tunnel. A baffle or a

series of baffles serves two purposes. It prevents the direct escape of the hot gases, allowing them to burn more completely. And a carefully placed baffle redirects the flow of the hot gases around the pot and increases the time the pot is exposed to the heat.

Baffles can be placed at the exit of the combustion chamber. Here they will redirect the flame and gases back onto the surface of the wood. These baffles also redirect the flame and gases under the pot surfaces. This heats the pots faster. Food cooks more quickly.

Baffles can also be placed in the flue. Here they will help keep the hot gases near the second and third pots. More heat is transferred to the pots. The food cooks more quickly.

ITDG has done tests that show that baffles can decrease wood use by 50 percent when placed correctly.

### Heat Exchanger

The heat exchangers in most of the stoves discussed in this manual are the pots themselves. These will vary from community to community and are as individual as the foods cooked in them. In Guatemala, cooking pots are often rounded clay vessels with relatively small necks. Cooks in many parts of the Sahel use round, open, iron kettles, while pots of aluminum or brass may be used in India.

## **Traditional stoves**

### Three Stones

The most basic, and one of the most common, wood-burning cook stove is simply three stones arranged on the ground in a triangle (see Figure 3). Use of this stove differs from region to region. One of the more efficient ways of using it will now be examined in detail.

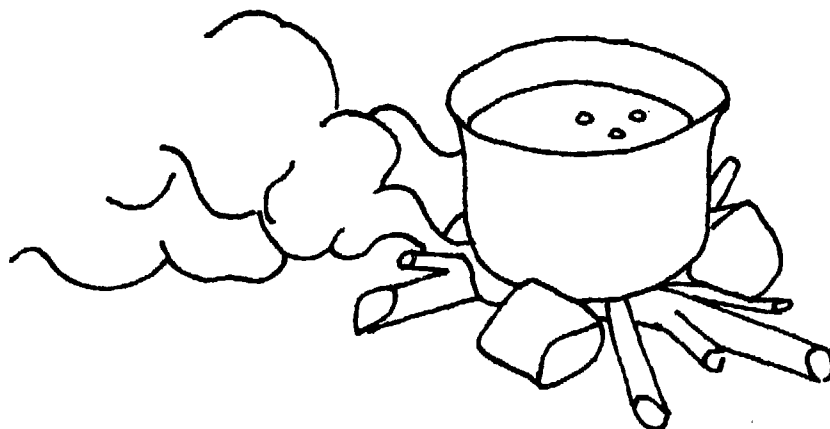
*Figure 3*

The fire is started with kindling. Once the kindling is burning, large pieces of wood are placed between the stones. A pot is then balanced on the stones. The amount of heat given off by the burning wood can be increased or decreased by moving the wood further into or further away from the center of the stones. After a short period of time the stones become heated to at least  $300^{\circ}$ - $500^{\circ}$ C ( $556^{\circ}$ - $932^{\circ}$ F). These hot stones absorb heat and also transfer some of it back to the fire, the pot, and the incoming air. This air also has to pass through the hot gaseous products of combustion. Thus the air is preheated and can therefore react more easily with the wood gases at the glowing ends of the sticks. So in the middle of the fire there is a very hot region with continual movement of hot gases out and the intake of colder air. Now, the energy to sustain the combustion of a piece of wood comes from both radiation from the flame and from the glowing tips of the other pieces of wood. As the pieces of wood are moved apart, the energy absorbed by any one piece decreases. Thus the rate of productivity of gases, tar, and charcoal decreases and therefore the total rate of heat released by the wood also decreases.

Three-stone cookers have a number of drawbacks. The pot loses large amounts of heat by convection, particularly if it is exposed to any breeze. The hot gases produced in the fire quickly spread away from the cooking vessel, so very little of their heat energy is transferred to the pot. If the wind is

blowing, these gases dissipate more quickly and even less of their energy is transferred. If the pot is placed very close to the seat of the flame, much soot and tar is formed; the relatively cold surface of the pot may lower the temperature of the gases below the ignition point. The smoke and danger of burns and spilling from pots are also drawbacks, as is the discomfort of cooking on the ground.

### Chulas

In many parts of southern Asia a mud stove known as a chula is widely used. There are many different versions of the chula. Probably the most common version is illustrated in Figure 4.

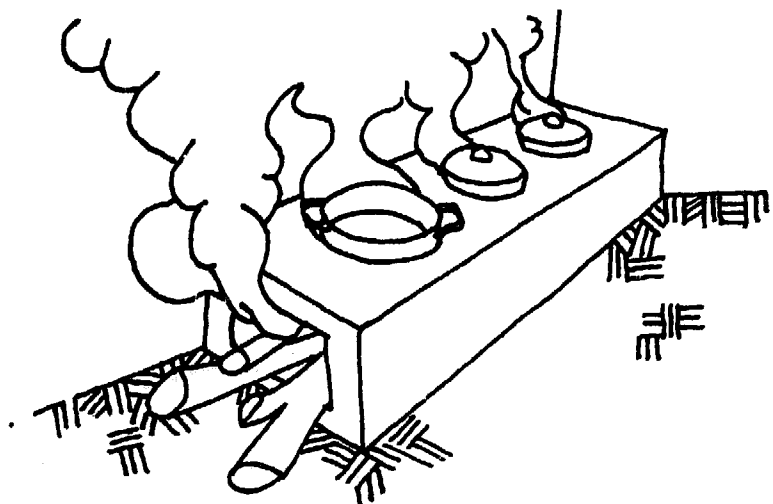

Figure 4

This stove consists of a hollow box with an opening at one end for inserting the wood, and a number of holes on top which allow cooking pots to be placed over the fire. The smoke escapes around the pot and out of the entrance. Under some conditions these stoves are less efficient than the three stones

configuration. Goldemberg and Brown (1979) have shown that the cooking pots absorb only a small percentage of the heat radiation emitted by the fire. But heat escaping up around the pot heats its sides fairly effectively by conduction. As the air enters the chula, it tends to flow over the top of the wood, not through or around it. Thus, much of this cold air flows directly into the flame zone. The large amount of excess air tends to lower the flame temperature and to prevent the ignition of the volatile wood gases.

A widely used chula that burns scrap wood and straw (see Figure 5) is found in Bangladesh. This stove is constructed in the ground and consists of two holes linked together. Around the larger hole are three raised points on which the pot is placed. Scraps of wood and waste are placed in the hole and lit. Air is drawn down the hole and mixes with the fuel. The flame and smoke are drawn up through the space between the pot and the pot stand.

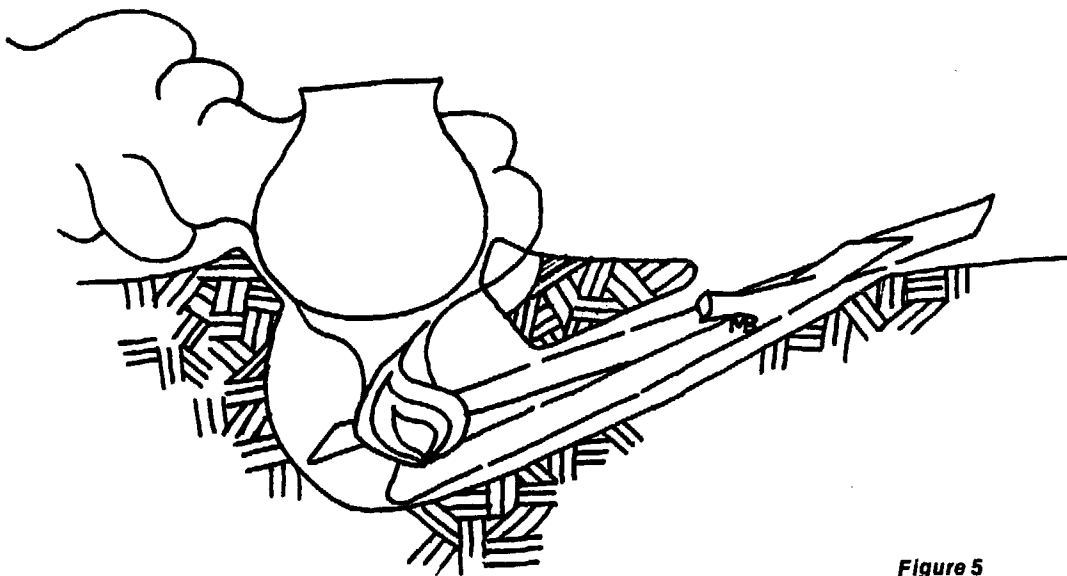

Figure 5

A more portable but less efficient version of this stove is seen in Figure 6. The stove is made by artisans from clay and dung, and is sold in the marketplace. Wood is placed through

the large hole and sits in the bottom of the stove. Visual observations indicate that only part of the incoming air is actually drawn down to where the wood is burning.

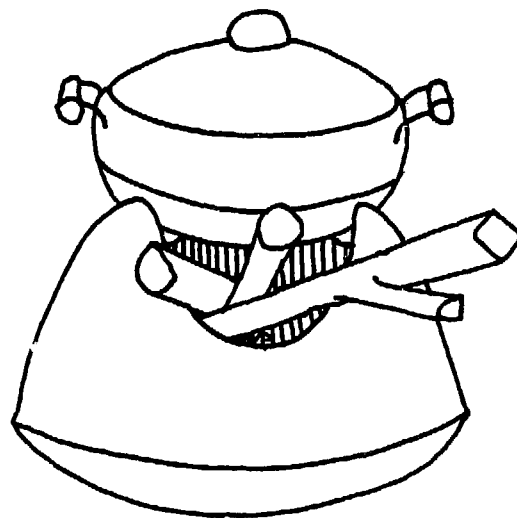

Figure 6

Stoves in Asia have been designed to burn rice hulls or sawdust. One widely used type is made of fired clay, with an inner spout that has been perforated. Rice hulls are placed in the spout. Burning twigs and paper are placed underneath. The heat from this burning material causes the rice hulls to catch fire.

There is a sawdust burning stove in northern Bali, Indonesia, that is built of adobe brick. Mud is plastered over the outside.

### Kamado-style Cooker

The traditional Japanese earthenware cooker, the Kamado, can serve as a design model easily adapted to the village situation (see Figure 7). Made almost entirely of ceramic, the Kamado consists of an outer insulating shell that holds a removable firebox and grate. A metal grill--the only non-ceramic part--sits on a ceramic ring that holds pot and food above the fire. A hinged lid allows the stove to be used open

or closed, permitting baking, boiling, frying, and barbecuing. The double-walled design of firebox within shell, as well as the ceramic material itself, serve to minimize heat conduction to the surrounding area. The temperature is controlled by adjusting the top damper and bottom damper to regulate the draft.

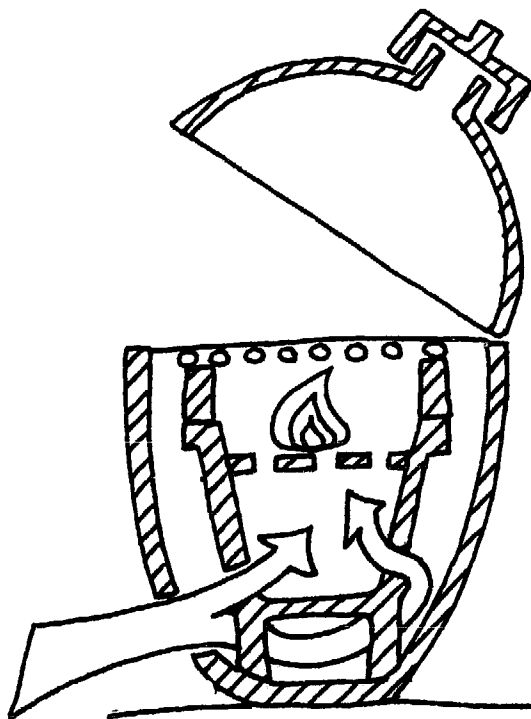

*Figure 7*

A 20-liter (5-gallon) drum or sheet metal cylinder can be substituted for the ceramic outer shell, though it will not possess the insulating capability of the original. The ceramic firebox and grate can be made locally in simple disc and cylinder shapes. They do not require firing in a high temperature kiln to be used in the stove.

## **Simple metal stoves**

Metal containers of approximately 20-liter (5-gallon) size can form the basis for several simple stoves.

### Rice Hull Stove

A small oil drum or other metal container, or a structure made of brick, forms the fuel chamber for rice hulls or sawdust. An air vent is made in the side of the container at the bottom. A 6cm (2-1/2") stick of wood is placed on the floor of the container through the vent hole. Another 6cm (2-1/2") thick piece of wood is placed in the center of the container so that it touches the end of the stick lying on the bottom.

Rice hulls or sawdust are poured around and over the two sticks and packed firmly with a block of wood. The chamber is filled to about 5cm (2") from the top. The two sticks are carefully removed, leaving a tunnel through the fuel from the air vent to the top.

### Sawdust Cook Stove

This stove is used to burn sawdust. It is very similar to the rice hull stove. It is made from a tin can approximately 25cm X 25cm (10" X 10"). A circular hole 10cm (4") in diameter is cut near the bottom of the tin. The inside of the tin is plastered with clay and cement 3cm (1-1/4") thick. Two bottles are placed inside the cooker and the space around them is filled with sawdust (see Figure 8). The bottles are then removed. Iron or steel rods or straps are placed across the top of the container to support the cooking vessel.

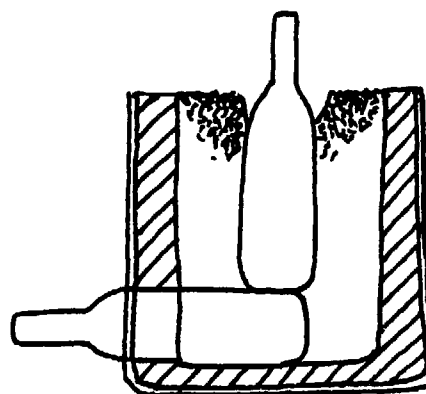

Figure 8



To light the fuel, a piece of firewood about half the thickness of the bottles used to form the air openings is used. This narrow stick is dipped in kerosene, set alight, and then carefully pushed, while still burning, into the air channel from the air vent (see Figure 9). When the fuel begins to burn, the pot is placed on the supports and the stove is ready for cooking (see Figure 10).

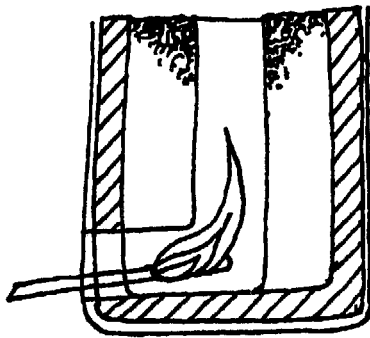

Figure 9

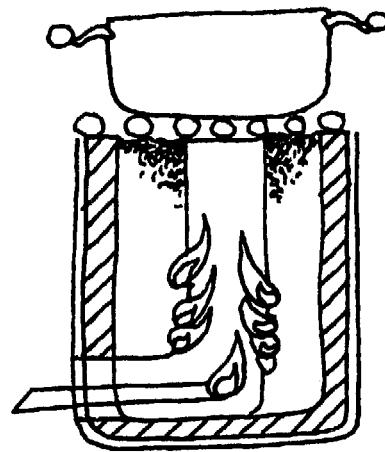

Figure 10

As the firewood burns, it is slowly pushed further into the opening. A 1m (39") length of wood, 2cm (3/4") in diameter, and a full chamber of sawdust are said to provide a cooking flame for two hours' cooking.

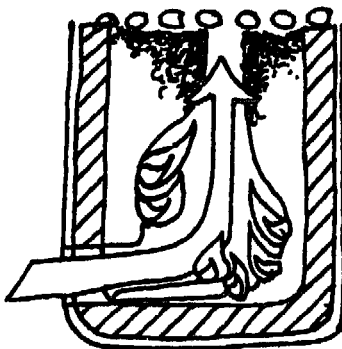

Figure 11

The air enters at the bottom of the hot inner casing, where it is heated. It then passes over the surface of the waste. The fuel burns outward leaving an onion-shaped cavity (Figure 11).

### Stove-in-a-bucket

A small, experimental cook stove consists of a commercially available galvanized metal bucket fitted with two grates (see Figure 12). One grate fits inside the bucket about 15-1/4cm (6") from the rim. This grate supports charcoal or firewood. The second grate goes on top of the bucket. Food is cooked here--either in a pot or grilled directly over the coals. This stove has not been field tested, but would probably be short lived.

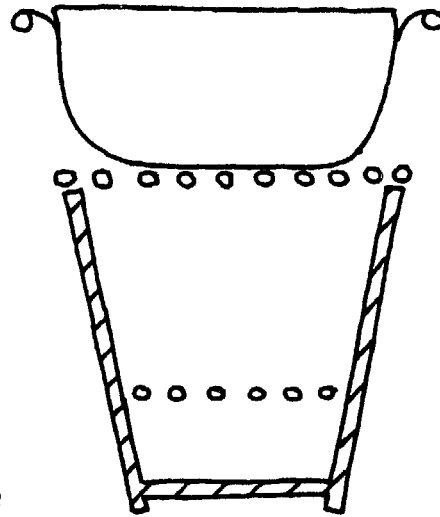

Figure 12

## 3. HOW TO MAKE STOVES EFFICIENT

The efficiency of a stove depends on many factors, from the design of the stove to the type of fuel used. This section discusses the ways in which energy losses can be reduced by improving the designs and the materials of traditional stoves.

### Conserving heat

#### *Energy losses in stoves*

Only part of the wood's chemical energy can be used to cook food or provide heat. Losses occur due to:

- . Incomplete combustion. Some of the volatile gases and charcoal produced during the burning process do not react with the incoming oxygen; thus, the heat that would be generated by these reactions is lost. Incomplete combustion leads to the formation of soot and tar particles in the gas stream leaving the combustion zone. It can also lead to the formation of carbon monoxide, which may accumulate to a dangerous level in the living quarters.
- . Heat carried away by the gases produced by combustion. The gases leaving the combustion zone are hot. Unless the pot can capture this heat, it is lost to the atmosphere. These gases also contain air. The greater the percentage of excess air (that is, the amount of air beyond that required to burn the wood completely), the greater the heat loss to the gas stream will be. Some heat energy is needed to exhaust flue gases and draw in combustion air.
- . Losses due to heating a stove. The stove absorbs heat from the fire. Some of this heat will be transferred to the pot, but some is lost.

- . Losses to the atmosphere from the stove walls and the cooking pot. Any hot object will radiate and conduct heat to anything cooler around it.
- . Energy used in evaporating excess water from wood with high moisture content.
- . Inefficient operation of the stove for intended purpose. Examples: Having a high draft to allow faster cooking. Not using pot covers while cooking. Using wood pieces that are too large or too small.

The first four losses can be minimized through proper stove design.

### ***Improving combustion efficiency***

As discussed previously, wood burns efficiently if there is enough, but not too much, air. There should be a temperature of about 500° to 600°C (932° to 1112°F) around the wood surface. High temperatures can be achieved by:

- . insulating the fire box (combustion chamber);
- . reflecting part of the heat absorbed by the walls back onto the wood surface (Figure 13);

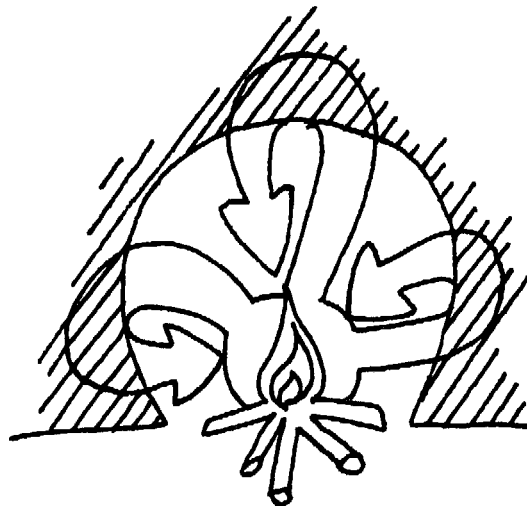

**Figure 13**

- . placing the pot away from the seat of the fire. The most efficient position for the pot is where the flame is not cooled by the pot's cold surface, but where the bottom of the pot still receives a large proportion of the radiant energy released from the fire;
- . controlling the flow of cold air to the fire.

Air can be channeled around the wood by the use of grates or baffles. There are five ways that the air can be forced to flow through the wood (see Figure 14).

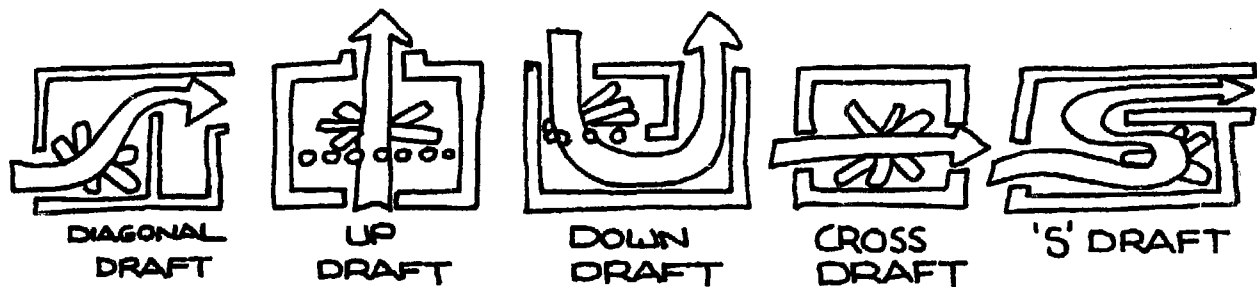

Figure 14

There is no evidence to date to show that any one of these designs is the best. However, it is known (Winkelman, 1953) that if a grate is used, the walls of the combustion chamber must slope in toward the grate (Figure 15), and that the area of the grate open to the passage of air must be approximately 25 to 30 percent of the total grate area.

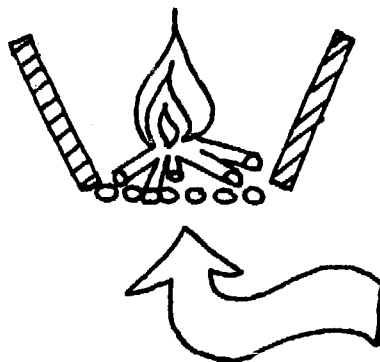

Figure 15

More sophisticated methods of improving combustion efficiency are:

- . recirculating the flue gases
- . preheating the primary air
- . adding secondary air at the end of the flame zone (Figure 16).

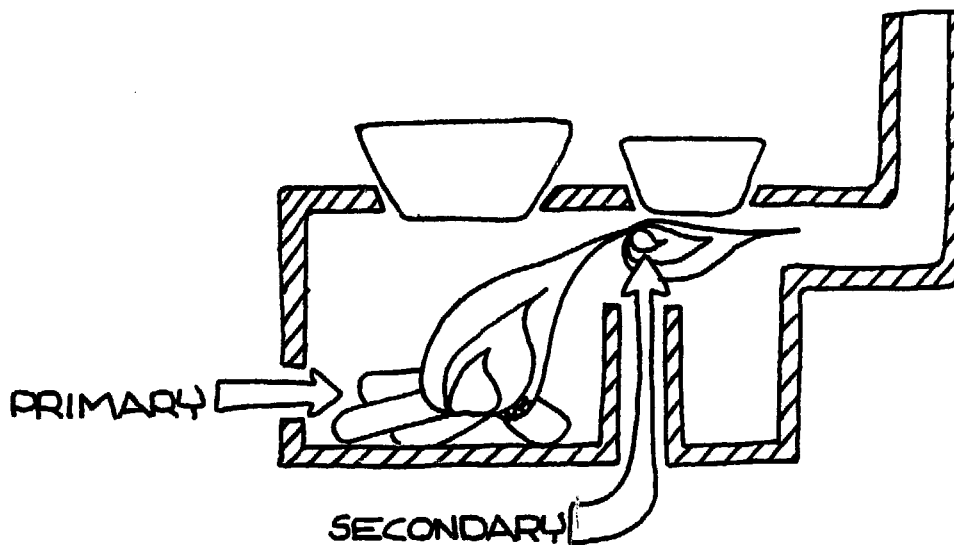

Figure 16

### **Using the heat from the gas stream**

The gases produced from the burning of wood in open fires escape almost immediately to the atmosphere. If these gases are taken from the combustion zone via the flue and passed around a pot, heat will be transferred from the gas stream to the colder pot. The longer the gases remain in contact with the pot and the more turbulent the motion of the gases, the greater will be the heat transferred. However, if too much heat is taken from these waste gases, water and creosote will condense out. Creosote can catch fire in the stove, and water causes corrosion of any metal stove parts.

### **Minimizing heat loss from heating the stove**

The heat required to heat a stove can be minimized in two ways. If food is to be cooked quickly, or once or twice a day, the stove should be designed with thin walls or of a material that does not readily absorb much heat. If cooking is done frequently throughout the day, a stove that has a thick wall and holds heat well should be constructed. This stove will always remain hot. When cooking, much less heat from the fire will be absorbed by these hot walls.

### **Minimizing heat losses from pots and stove walls**

Losses from pots can be minimized by heating the pots to the boiling point very quickly, and by preventing a draft from flowing around the pot. Setting the pot in the hot gas stream can prevent drafts. Considerably less heat is lost if the pot has a tight-fitting lid. A flat-bottomed pot captures radiant heat more efficiently than a round pot. However, the round-bottomed pot seems to capture heat more efficiently when the main form of heat transfer is via convection. Pots made of metal transfer heat much faster than earthenware pots.

The amount of heat lost from a stove depends on the outer wall temperature of the stove and the speed of the air flowing past the stove. The closer the stove wall temperature is to the surrounding air temperature and the lower the speed of air flowing past the stove, the lower are the losses. Heat losses from stove walls can be lowered with some stoves by a double wall or brick lining.

### **Improving traditional stoves**

It is important when designing or improving any stove to look at the functions that stoves perform in the society in which they are used. Some seemingly laborious or inefficient stoves have great social significance. New stove designs should be adapted to the local traditional

cooking customs, cooking pots, and the types of food to be cooked.

Designers have followed two approaches in improving traditional stoves: combustion chamber engineering and the chimney-and-damper approach.

### **Combustion chamber engineering**

This involves modifying a traditional stove by insulating the firebox, changing the shape of the combustion chamber, or other means. This is the most recent approach being pursued by several organizations, including the Intermediate Technology Development Group (ITDG) of England. None of these stoves has been field tested. However, initial results for stoves designed using this method are very promising. A few case studies follow.

The Bangladesh chula--Dr. Nuruzzaman of the Bangladesh Council of Scientific and Industrial Research is carrying out work on this stove. Dr. Nuruzzaman observed incomplete burning of the wood in the bottom of the stove. Using a thermocouple, he measured the vertical distribution of temperature down the center of the stove. He inserted a ceramic grate at the hottest place and put the wood on this grate. He found that the amount of wood required to boil water was considerably reduced.

Thai stove--While this is a charcoal-burning stove, the design principles used can be relevant to designers of wood-burning stoves. Keith Openshaw greatly reduced the amount of charcoal used and the amount of time required to prepare a meal on a traditional metal charcoal burner used in Tanzania. To improve this stove, he decided to insulate the sides, make them slope inward, and improve the distribution of air around the charcoal. Openshaw found that a stove manufactured in Thailand met his requirements (see Figure 17).

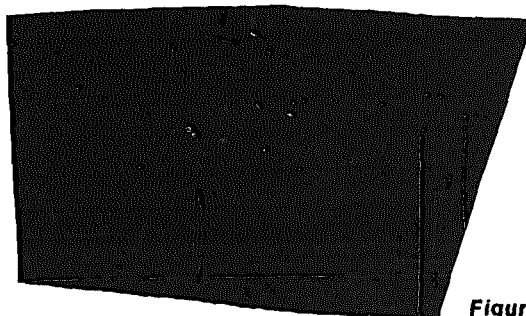

Figure 17



He provides the following description of the stove:

The clay stove described here originated in Thailand. It usually has three layers, although it may be purchased without the outer metal cover and middle ash layer. It is made almost entirely of local materials--clay and ash. Only the outer metal is paid for in foreign exchange. This outer metal cover is to give the stove more durability. It is generally made from old tin cans such as are used for packing fruit. The middle layer is filled with ash (rice straw ash in this particular case), and has a simple cement seal to contain the ash. The inner layer is made of burnt clay about 3cm thick at the top, tapering to about 1cm at the base. The fire grate is made of the same burnt clay material and secured with cement. If the grate breaks, it can be replaced without the need to buy a new stove. It is usual to buy one or two extra grates at the time of purchase. The air space in the grate is about 25 percent of the total area of the base, as compared to about 10 percent in the metal stove. This could be one of the design features that make this type of stove more efficient. The clay stove has a larger diameter at the top than at the base and this acts as a kind of self-stoking device. It was noticed that unlike the metal stove, the charcoal never had to be moved around to obtain a complete burn, another good design feature. The rim of the stove has three raised platforms which support the pots and pans, and three depressions which allow an inflow of air at the top to supplement the air inflow at the base. The air intake at the base does not have a door, but it may be restricted by using a brick. Again there are various stove sizes, but the dimensions shown in Figure 17 are typical for household use.

In field tests Openshaw found that this Thai stove took half as much charcoal to boil water as the metal equivalent.

Dr. de Lepelriere's metal stove--This stove was designed for use in Africa. The stove was initially constructed from metal. It has an inner combustion chamber that slopes at a 45° angle. The

chamber has a number of holes around the outside. The combustion chamber sits inside a metal outer casing. The pot is placed inside, halfway down this outer casing (see Figure 18).

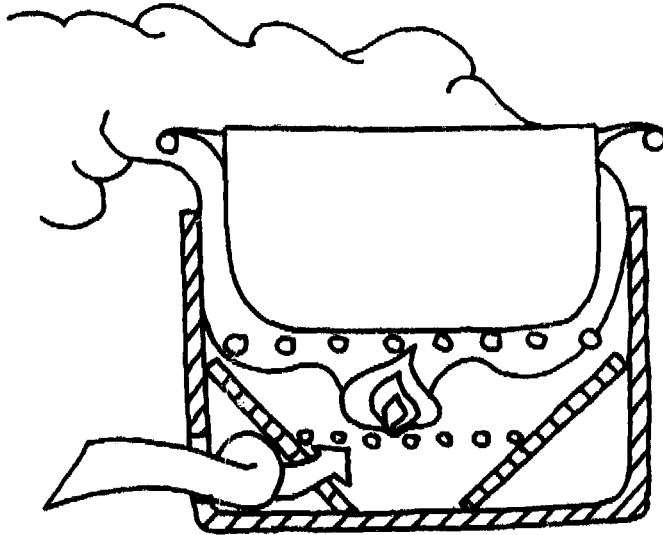

Figure 18

The air enters through the outer casing and absorbs heat from the hot inner chamber. This preheated air then enters through the inlet holes around the fuel. The incoming air serves effectively as an insulating layer between the combustion chamber and the outside. The heat that is lost from the fire is partially reintroduced by the incoming air.

Heat is transferred to the pot both by radiation from the fire and by convection as the hot gases flow around it as they leave the stove. When the water in the pot has boiled, the rate of heat released can be lowered by placing mud over part of the inlet hole.

The main disadvantage of this stove is that it requires fuel-wood cut into small pieces.

ITDG stove--Two traditional Indian stoves were joined to make this stove. Still quite new, the stove has not yet been field

tested. The stove was designed to be portable, built by local craftspeople, and used for both cooking and baking (Figure 19).

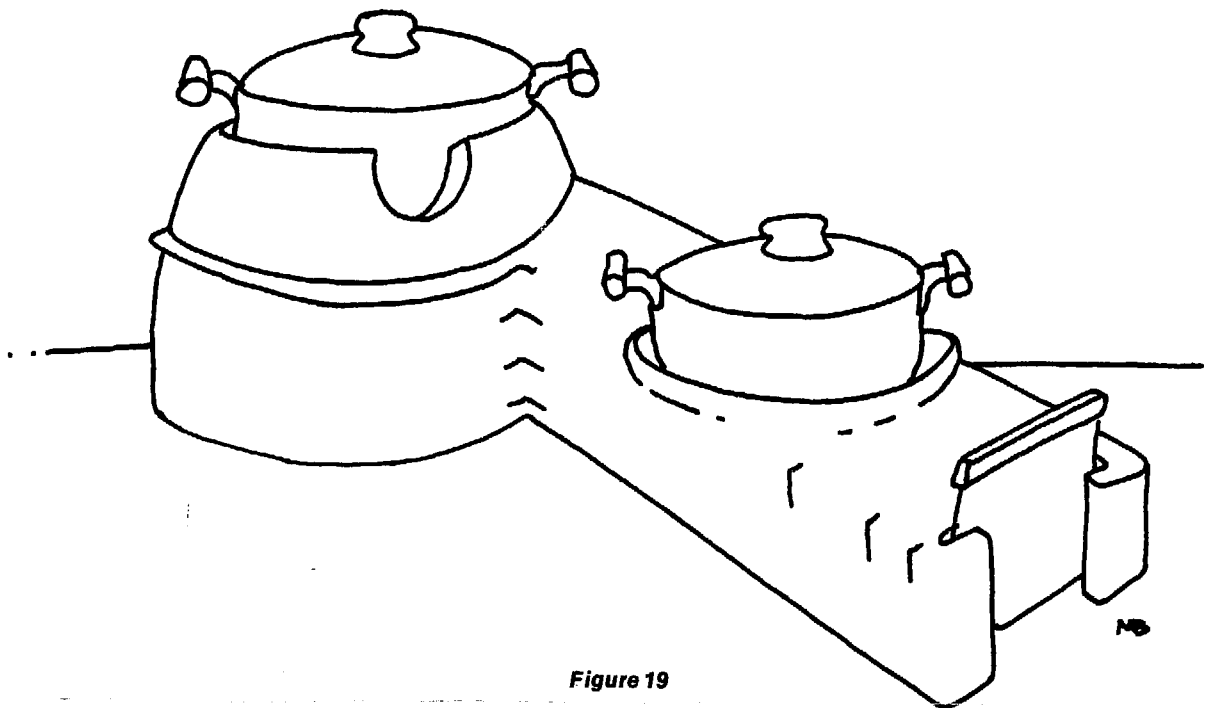

Figure 19

The stove consists of two sections: a hollow box similar to the chula described on page 21, and an oven, or Tandoor. A grate is placed inside the firebox under the area where the first pot rests. The firebox is narrow towards its front, allowing the wood to serve as its own damper. Wood is fed into it continuously. The heat released depends on the length of the wood lying over the grate. The cooking port is designed to hold the hot plates used for making chapatis, or to hold round-bottomed pots. The fire can be controlled by covering the inlet air hole.

A small baffle is placed at the other end of the firebox. Gases and flame enter the Tandoor parallel to its walls. There is a great deal of turbulence in this region, and most of the volatile wood gases and tars react with the oxygen to form a very clean gas composed mainly of carbon dioxide and water vapor.

The hot gases then circulate around the lower wall and around the pot that has been placed in the outlet. Heat is transferred both to the pot and to the walls of the Tandoor. Depending on the length of time that the stove has been in use, the residual heat can be used to bake bread.

### ***The chimney-and-damper approach***

Much of the earlier work carried out to improve traditional stoves was based on the development of airtight stoves in European countries. Two features distinguish these stoves from those just described:

- . the ability to restrict the air entering the stove to a single place; and
- . the use of a long pipe or chimney to take the combustion products away from the stove and supply the necessary pressure forces to cause the air to enter the stove.

All of these stoves have the same basic components: an air and wood inlet, an airtight combustion chamber or firebox, chimney, heating surfaces, and adjoining flues.

Air and wood inlet--Except in some updraft stoves, wood and air enter through the same opening. The air is controlled by a damper at the front of the stove or at the back of the firebox or flue. If the damper is placed at the back, wood can be fed in continuously.

Airtight combustion chamber or firebox--See **HOW TO MAKE STOVES EFFICIENT, Improving Combustion Efficiency.**

Chimney--The function of the chimney is to draw water vapor and smoke out of the kitchen and to create a pressure difference so that air is drawn into the firebox.

The chimney can be made from clay pipes, sheet metal, cast iron, masonry, concrete pipes, bamboo, and so on. Brick or clay

pipes will have a longer life than sheet metal chimneys. The length and diameter of a chimney are very important. The bigger the stove, the greater should be the size of the chimney. If the chimney is not big enough, the stove will not be able to draw in enough air to operate at maximum efficiency. However, if the chimney is too big, the stove may be difficult to operate and heat losses will be increased. The maximum amount of air that enters the stove can be altered much more effectively by changing the diameter of the chimney than by changing its length. It is advisable not to have a diameter greater than 15-1/4cm (6"), as cold air could flow back down the chimney. The height and diameter can be worked out theoretically; however, trial and error is sufficient in most field situations. The length of the chimney is controlled by the height of the house; it should be higher than the highest point of the roof.

When placing a chimney through a roof (especially one made of thatch) it is advisable to place a metal thimble around the chimney. A tin can may be used as a thimble (see Figure 20).

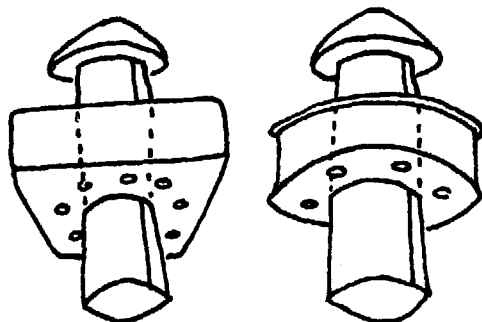

Figure 20

The chimney must be cleaned regularly to prevent fires. How often the chimney needs to be cleaned depends on how hot the stack gets, how green was the wood, and how much water was in the fuel. Normally the chimney would need cleaning every one to six months.

Heating surfaces and adjoining flues--There are two basic designs for transferring the wood's energy to the pots and for transferring the gases from the firebox to the outside of the house.

The most widely used design for European cooking stoves is shown in Figure 21. One or two pots are positioned over the firebox and the other pots are placed over a second chamber that adjoins the firebox. Flames touch these pots when the damper on the air inlet is fully open. The pots also receive heat from the hot top plate that covers the stove. Waste gases usually flow past the oven and up the chimney. The sides and bottom of this stove are insulated.

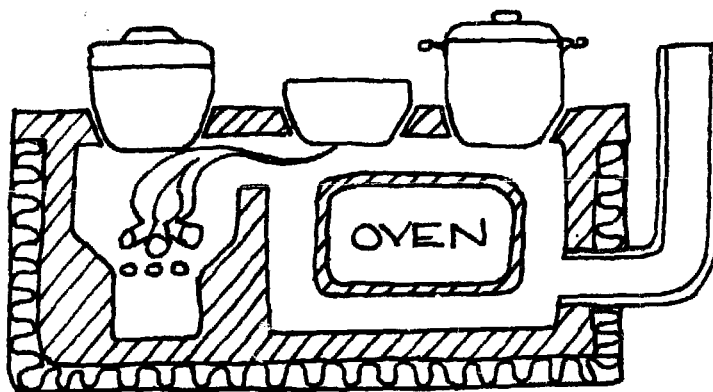

Figure 21

An alternative design (see Figure 22) that has been tested by ITDG has proved reasonably successful. A checkerboard of bricks is placed in the second chamber. When the stove is operating at high heat the waste gases transfer their heat to these bricks. When the fire dies down these hot bricks reradiate the stored heat to the pots.

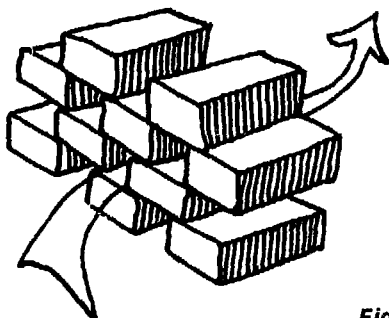

Figure 22

A simpler version of Figure 21 made from sheet metal has been designed by Dr. de Lepelierre (see Figure 23). The combustion chamber has been shaped to accommodate long pieces of wood. Air enters the combustion chamber underneath the stove. Both pots receive heat radiated from the flame. The hot flue gases also transfer some of their heat via convection as they pass around the two pots. All of the stove's surfaces, however, become very hot and radiate heat into the room. Also, it is difficult to remove the pots from the stove.

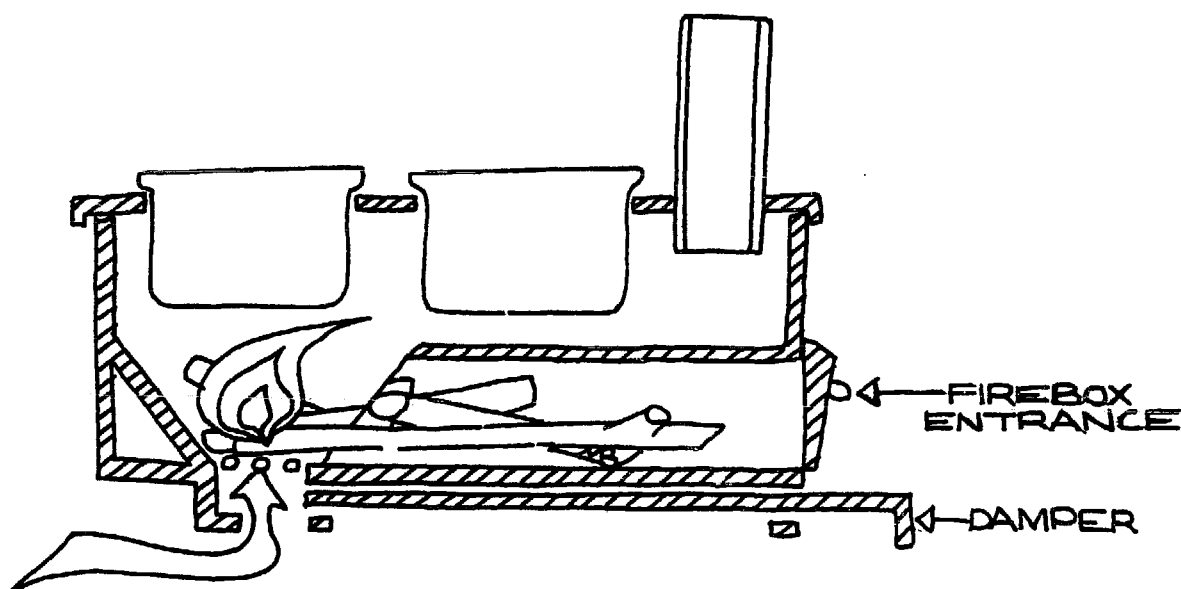

Figure 23

The second type of design was developed in India in the 1950s by the Hyderabad Engineering Research Laboratory (see Figure 24). Known as the HERL or smokeless chula, it was based on traditional Indian chulas and adapted by S.P. Raju, former director of the laboratory. Today it forms the basis of many of the stove designs being promoted throughout the world.

The HERL chula is basically an "L" shaped block of bricks and mud, with holes on top for cooking pots. A tunnel runs horizontally through the stove. The fire is built at the front of the

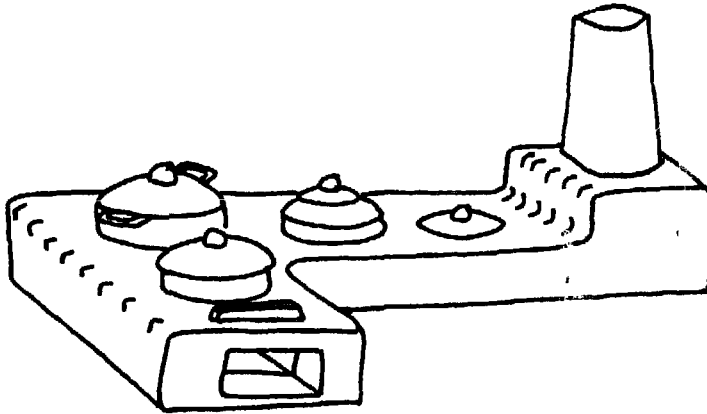

Figure 24

tunnel beneath the first pot. A chimney of clay or sheet metal is installed at the other end. Hot gases and flames flow through the tunnel, under the pots, and up the chimney. A damper provides draft control. The number of pot holes and the size and height of the stove can be adjusted to the user's needs.

Some possible drawbacks of this type of stove are:

- . It is not portable.
- . The damper must be used properly if there is to be a marked saving in fuel consumption.
- . To use this stove efficiently, the three cooking ports must be covered. When three pots cover the holes, the first two will gain heat fairly rapidly, while the third will take a longer time to heat up. The efficiency of the stove decreases markedly if the cooking holes are not covered. Should the family want to cook only one or two dishes, covers need to be placed over unused cooking holes.
- . Much of the wood's energy is used in heating the stove in the heavier models. It is advisable not to let these stoves cool down. Regular use during the day will achieve this end.



- . These stoves can be dangerous to use. The stove will produce carbon monoxide when the damper of the air inlet is closed. The occupants could be poisoned if this carbon monoxide escapes to a poorly ventilated room.
- . Cracks can form around the cooking holes. Heat and smoke will escape if these cracks are not mended regularly.

Two successful adaptations of the HERL chula are included in this manual: the Singer stove and the Lorena stove (see **4. HOW TO BUILD FOUR STOVES**). Both stoves rely on the same basic design element, i.e., a tunnel carrying hot gases beneath and past the pots, and the addition of a chimney. Both stoves are examples of how the basic chula has been adapted to suit local cooking preferences and to utilize available building materials. The Singer stove is assembled from smaller blocks. The Lorena stove is built from a massive sand and clay block.

The Lorena stove's design concepts differ from both the Singer and the HERL stoves in the following ways:

- . The front damper controls not only how much oxygen is available, but where it is available and how fast it strikes the bed of coals. This gives it a very fast response. It can be fired up very quickly from coals, and can be damped down more gradually. It also means that it can burn material which is not easily combustible, such as sawdust, bark, corncobs and, possibly, peat.
- . The proportion of sand (up to 85 percent) creates a new material that is neither adobe, clay, nor brick. This material has a strength property near that of concrete.
- . The great mass of a Lorena stove is sometimes an advantage. It enables the stove to absorb a great deal of heat. This makes the chimney temperature very low. The stove should have a long, circuitous tunnel system for it to work well.

Of the three stoves discussed, the Lorena stove has found the widest acceptance. Recent work in Nepal has shown that it uses

much less wood than the HERL chula. Work is continuing on its development. Details of improved versions are being published regularly by Volunteers in Asia and by the Aprovecho Institute.

Because monolithic and brick stoves cannot be moved, some work has been carried out on the design of a ceramic stove that can be assembled in one place and then transported to the place in which it will be used. This stove, the portable Magan Chula (see Figure 25), has been designed, built, and disseminated by the Gandhiniketan Ashram. It consists of a number of single ovens that serve as pot seats, and a chimney base and round flues that connect the ovens. These are all made by a potter, either by hand or on a wheel. Holes

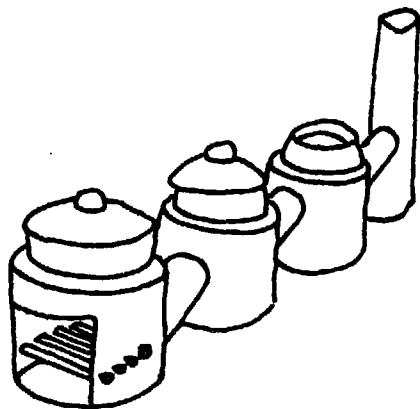

Figure 25

are provided in the side walls of the ovens for the linkpipes that join one oven to another, and the last oven to the chimney. The various parts are assembled in the home. Each joint is secured and made airtight with mud. A baffle is placed in the middle to help promote heat transfer once the ovens have been joined. The passages connecting the first pot seat to the second and third incline upward toward the chimney base. This improves the stove's performance.

Improved mud stoves have also been adapted to burn agricultural waste and sawdust. The waste is burned on a step grate placed inside the stove. The waste is fed from a hopper onto this grate. These stoves are used widely throughout Asia. They can be constructed from adobe bricks, heat resistant cement, steel, or ceramic material. The grate is usually inclined at a 45° angle. The percentage area of the grate that is open is 25-40 percent of the total grate area (see Figure 26).

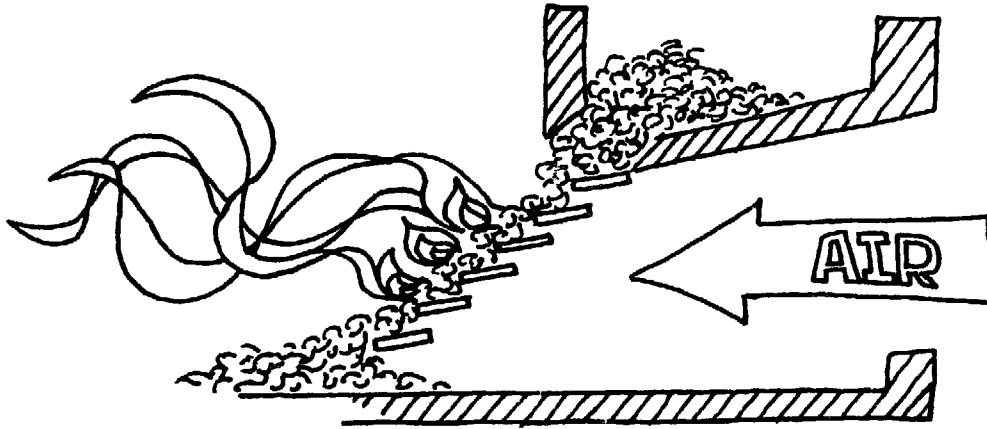

Figure 26

The efficiency of these stoves is affected by the rate at which fuel is fed into them. Mukhopadhuay found that the maximum heat occurred at a feed rate of 3.5kg/hr for a stove with a grate area of 570cm<sup>2</sup>. As yet, there is little information on the effect of changing the size and shape of the firebox and flues.

A step grate stove being disseminated throughout the Philippines is the Ipa stove (see Figure 27). It is constructed of adobe blocks with a cement top. The chimney is made from sheet steel. The cooking holes have cast iron covers.

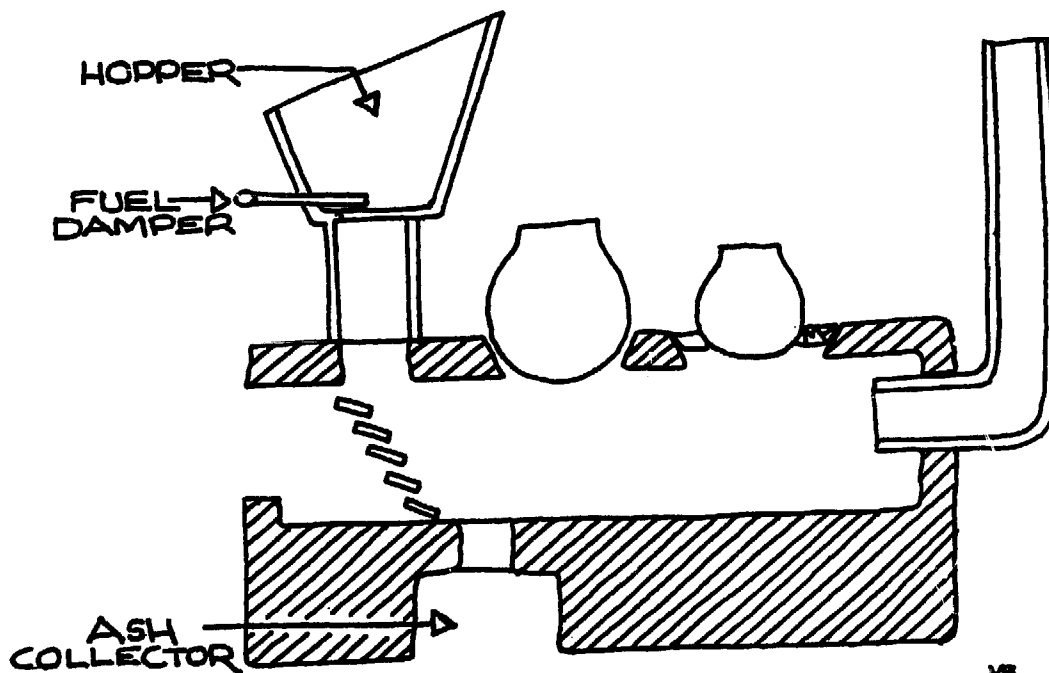

Figure 27

These stoves have also been widely modified for use in food processing. Figure 28 shows a stove used by 'gula jawa' coconut sugar producers in Blitar, East Java. It uses rice hulls for fuel. At 3,500 Indonesian rupiahs (about \$8 US), this is one of the cheapest natural draft stoves available. Clay mortar is used rather than cement. The 1-1/2m (5') chimney draws flames back to the last pot, 1-1/4m (4-1/2') from the burning hulls in the grate. The floor slants slightly upward toward the back of the stove to increase the draft. The grate is a piece of perforated iron sheet placed almost vertically in the mouth of the stove. There is some evidence that this type of grate is as efficient as a step grate (Bruce Lamb, 1979). The stove will not operate with the pots removed. When the pots are replaced, air leaks around the edges are simply patched with a mixture of mud and rice hull ash.

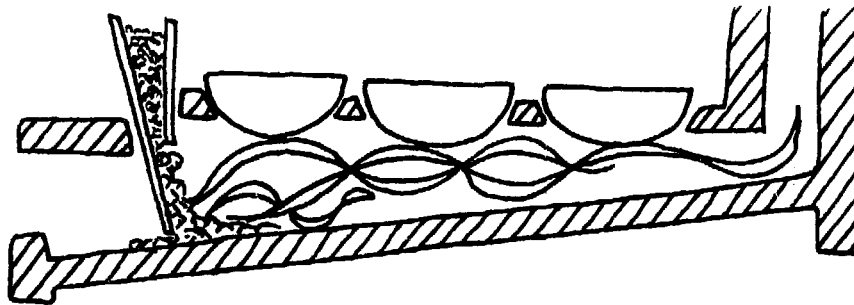

Figure 28

The pot nearest the fire is the hottest, and the one nearest the chimney is the coolest. This is especially well suited to the process of cooking gula jawa, as different temperatures are required at different stages of the process. The temperatures of the pots range from a fast to a slow boil.

This stove is used daily to boil down 50 liters (about 30 gallons) of coconut sap to 7kg (about 3-1/2 lb) of light brown sugar cake. This requires half a gunny sack (about 6kg [3 lb]) of rice hulls daily, burned over a period of four hours.

J.C. Overhaarte of the Technische Hogeschool, Eindhoven, The Netherlands, has designed a metal stove that is portable and burns both waste and small pieces of wood. Primary air enters through four cylinders into the middle of the combustion chamber. A pot sits on top of the firebox. The hot gases flow underneath the pot and around the firebox. The gases transmit some of their heat to both the primary air inlets and to a second pot that is placed on the base of the stove. This stove would radiate a lot of heat, but would not have a lifetime of more than 12 months in humid conditions.

Another stove (see Figure 29), made from a small oil drum, is reported to use half of the fuel that an open fire would use. The edges around the firebox door are bent back to avoid the danger of cut fingers.

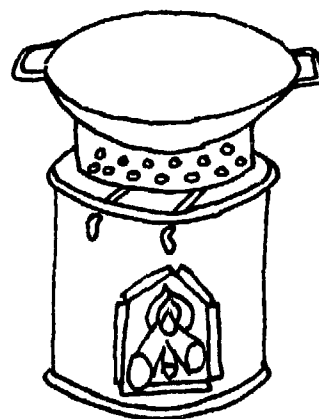

Figure 29

## Improving stove building materials

The efficiency, safety, and durability of a stove depend on the materials and construction skills used. For example, a mud stove with cracks around the firebox or cooking holes will let heat out. Smoke and poisonous gases may escape into the room.

### **Cast iron, steel plate and sheet metal**

Most stoves produced in Europe and America are made of cast iron or sheet plate (at least 34mm [about 1/10"] thick). They

last a long time (at least five years) and are very good conductors and radiators of heat. They can be produced in a small workshop or foundry, but are expensive to make and require considerable care in their construction if they are to be airtight. These stoves are mainly used for heating, and must be insulated using a refractory brick if they are to be used for cooking only. To date only one cast iron stove has been produced specifically for Third World countries. There is no information available on its performance or cost. Cast iron cooking surfaces are available in the developing world, however. These stoves often have removable rings so that pots of different sizes can be used.

Sheet steel stoves are used widely in both developed and developing countries. There are some important ways in which these stoves can be improved--without increasing production costs.

Corrosion of the steel can be inhibited by using a stove enamel or by lining the stove with clay.<sup>1</sup> This will increase the life of the stove.

Traditional methods of fabrication can be improved, resulting in airtight stoves of a more efficient design. Ole Wike's book,

---

<sup>1</sup>Richolson (1979) gives this formula for stove polish:

	<u>US</u>	<u>Metric</u>
Graphite	1 pound	453.6 gm
Lamp Black	1 ounce	28.4 gm
Rosin	4 ounces	113.4 gm
Turpentine	1 gallon	3.8 liters

Richolson modified the formula for Rijian conditions by substituting kauri gum (*Kadua makadre*) for rosin and by using a mixture of turpentine and methyl alcohol in equal parts to dissolve the gum. The gum also appeared soluble in ethyl alcohol, but not in either methyl alcohol or turpentine alone. Carbon cores from spent flashlight batteries can be used for graphite. The stove polish should be rubbed into the surface of the steel regularly after the stove has been used to slow corrosion.

Wood Stoves: How to Make and Use Them, is recommended for those wishing to improve traditional sheet steel stoves.

## **Ceramic**

Many societies use fired clay pots as cooking vessels. The pots are made by local craftspeople. However, with the introduction of steel and aluminum pots, the need for these craftspeople is diminishing. Another source of revenue for them could be provided by the production of fired clay stoves.

Pottery is not a material that withstands uneven heating or constant heating and cooling. When designing a pottery stove, care must be taken to:

- . Make the clay very open. This can be achieved by adding sawdust, or material fibers and crushed brick, or discarded fired pottery (grog).
- . Use clays that can withstand heat.<sup>2</sup>
- . Reinforce the outside of the stove with steel wire or sheet.
- . Line the inside of the stove with a heat resistant lining.

Pottery stoves heat up very quickly, are portable, and do not take nearly as long to construct as mud stoves.

## **Mud and brick**

"Mud" stoves are traditional in many areas. The mud is usually soil with a high clay content, mixed with cow dung, straw, sand, etc.

---

<sup>2</sup>At present this is generally ascertained through trial and error. However, work is being carried out by ITDG and collaborating organizations to develop materials that can be added to clay to improve its refractory properties. The results of this work will be published in the near future.

Different soils have different properties. Before a mud stove is made, the local soil should be tested. If it does not have the right proportion of clay to sand (about 20 to 30 percent clay and 70 to 80 percent sand), then extra clay or sand must be mixed in.

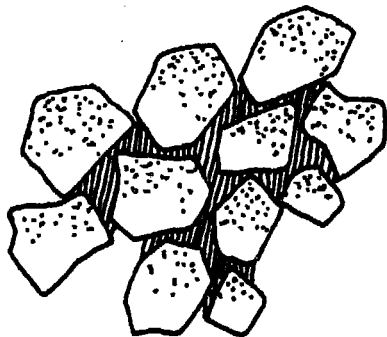

Figure 30

The Lorena stove described elsewhere in this manual is made of a mixture that is mostly sand. Sand does not shrink when it dries because the individual grains of sand are rigid and hold each other apart (see Figure 30). The clay is the glue needed to hold the sand grains together. Clay and sand must be mixed together very thoroughly, as unmixed clay balls weaken the mix and prevent it from holding together.

The lorena mix needs only three ingredients:

- . a lot of sand to form the mass of the stove
- . a little clay to glue the sand mass together
- . water

If a pure clay soil is used, a lorena mix that is 75 to 85 percent sand must be made. When soils with less clay are used, less sand must also be used, especially if there is already sand in the soil. If the soil is of the clay-silt type, the silt does not help much, so the sand percentage should remain high (see Figure 31).

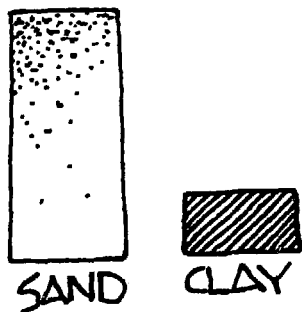

Figure 31

Lorena ideally needs a fairly coarse sand and a soil with a high percentage of clay. More



than 60 percent clay is ideal. Avoid silty soils and soils without clay (such as volcanic ash soils and sandy soils), since these will have little or no glue power to hold the sand mass together.

One formula (Flickinger, 1979) was recently developed in Indonesia for soils low in clay:

1/2 to 1 part wood ash }  
 1 part clay } mix together with a little water

2 parts sand

3/4 part grain chaff

1 pan constarch or cassava starch

Soils with less than half clay can be used if they are already mixtures of clay and sand rather than clay and silt. Organic matter (leaves, twigs, straw or husks) in the soil creates problems, so use subsoil whenever possible. The soil used is from at least 20 to 40cm (about a foot) beneath the surface (see Figure 32).

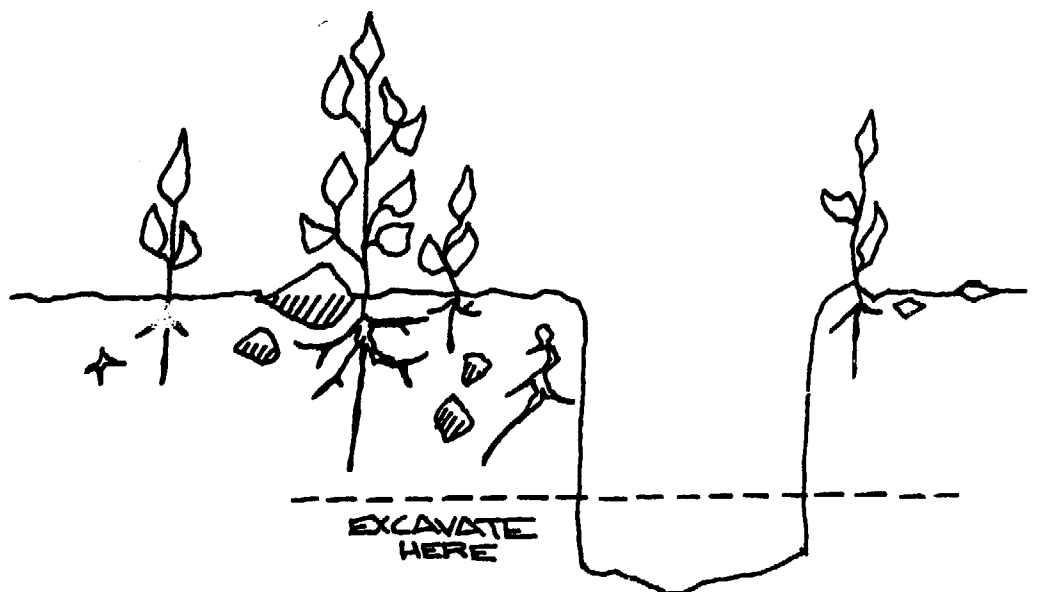

Figure 32

Making the correct lorena mix is very important.

With too much clay the lorena mass, as it dries, shrinks unevenly and cracks the stove.

With too much sand the lorena is too soft and the mass will fall apart.

With too much silt the sand/clay mix is diluted, causing interior tunnel surfaces to flake away in the heat of a cooking fire.

Stove builders using unfamiliar soils should first talk with a local brick or adobe maker to determine what the soil is like. One test is to make mud balls about the size of a chicken egg. Fire them in a hot fire. Check which mixture gives the hardest ball without cracking. In addition, it is recommended that a small test stove be built if the soils are unfamiliar. Test the small stove with fires for about a week and watch carefully for cracks, especially around the firebox. If there are no cracks after a week of use, it is fairly certain that it will not crack later.

If there is very little clay in the soil, another material will have to be found to glue the sand mass together. Experiments have been carried out with raw sugar (it is used in building Mexican bread ovens), but more experiments with suitable glue materials are needed.

Remember that although a 1:4 lorena mix (one portion soil mixed with four portions sand) may be necessary in one place, a short distance away a 1:2 or 1:1 lorena mix may be necessary. Even two layers of soil right next to each other may have very different clay contents.

Use the following lorena mix chart as a guide for soil/sand proportions. Watch carefully for cracks in the first stove produced, and be prepared to change the mix.

	<u>Soil</u> <u>(Percent)</u>	<u>Sand</u> <u>(Percent)</u>	<u>Proportion</u>
Pure clay soils	15-25	75-85	1:5 to 1:3
Clay/sand soils	25-35	65-75	1:3 to 1:2
Clay/silt soils	25-35	65-75	1:3 to 1:2

To test to find out how much clay is in a soil, take a small handful of soil, add water to make a stiff mud, then mix it well in your hand. Open your hand and make a flat mud cake on your palm (see Figure 33). Slowly close your hand. The cake should shine as your hand begins to close. (If not, add water and try again.) If the shine goes away when your hand is opened out flat again, it means that the soil probably has a high proportion of sand or silt in it. If the shine does not go away, it probably means that the soil contains a lot of clay.

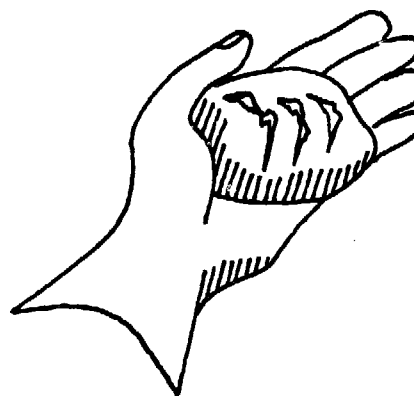

Figure 33

Wet the soil until it becomes a stiff mud (thoroughly moist but not watery). Roll the stiff mud into a pencil-thin worm of soil about 10cm (4") long. The palm of your hand can be used to roll out the worm on a flat, hard surface. Carefully pick up the worm of stiff mud at one end with just two of your fingers (see Figure 34). Hold the worm parallel to the ground. If the worm breaks off, it contains a lot of silt or sand. If it bends or sags but does not break off, it contains a lot of clay.

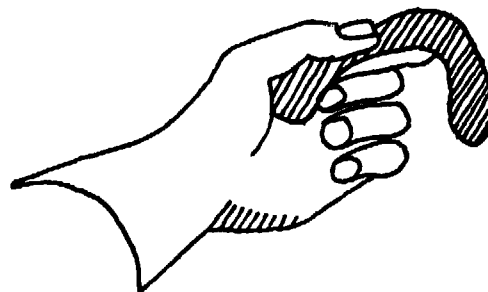

Figure 34

### Preparing bricks for stove construction

If the stove is to be constructed with sun-dried or kiln-fired bricks, use clays that have very little sand. For sun-dried bricks, a mixture is made of 50 percent by volume of clay, 40 percent by volume of sawdust, and 10 percent by volume of a binder--ash or cow dung being preferred. These materials are mixed with water, placed in a mold, and left to dry in the sun. The bricks are joined together using mortar, lime and sand, or clay and sand as mortar.

The inside of these stoves can be further protected from the hot corrosive gases by plastering with a mixture of water, clay (kaolin), and powdered quartz. If the latter is not available, cow dung mixed with a small amount of clay can be used. Material from an ant hill, crushed fine and mixed with clay, also provides a heat-resistant coating.

If these clay bricks are fired in a kiln, they will last much longer. The bricks that are to be closest to the heat in the stove should be slop-molded. This involves mixing the clay with sawdust, 50 percent by volume. Water is added until the mixture is very wet. The mixture is then poured into a mold. When the brick is fired, it has a very open structure that can withstand high temperatures. This type of brick also provides insulation for the combustion chamber. However, these bricks are not very strong and must either be surrounded by sturdier bricks, or have an outer coating of lime or cement mortar.

## 4. HOW TO BUILD FOUR STOVES

This chapter outlines general construction procedures for four types of wood conserving cook stoves:

1. The Lorena stove
2. The smokeless chula
3. The Singer stove
4. A simple metal stove

All of the stoves have been built and used successfully. Some modification may be necessary to adapt the designs to local conditions. Complete construction references are found in the Bibliography.

### Lorena stove

The Lorena stove (see Figure 35) was developed in Guatemala. It resembles an improved Indian chula. It can reduce wood consumption by 25 to 50 percent if used properly.

An active program in Guatemala promotes the lorena design as widely as possible. It has become very popular there and elsewhere. Small businesses now build the stove for local families who do not want to build their own.

There are many reasons for this popularity. The stove can be built by unskilled workers using local materials. Its size can be changed for different families. Only simple hand tools are needed. Most important, the basic technology can be adapted broadly to different conditions and traditions.

The stove also offers these technical advantages:

# LORENA STOVE

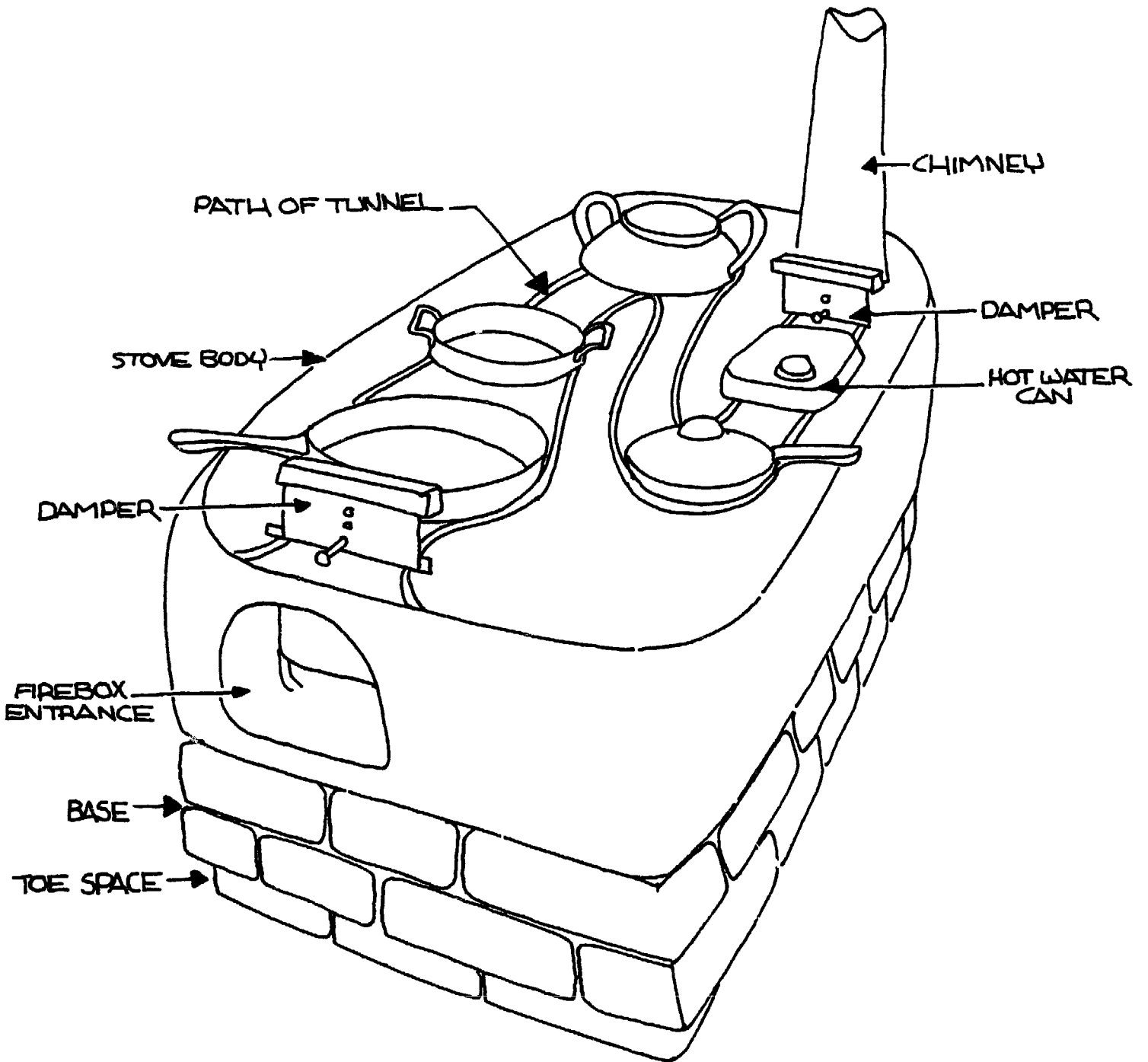

Figure 35

1. The long tunnel system extracts heat from the flue gases. This heat would otherwise be lost up the flue.
2. The high stove mass stores heat for cooking and baking even after the fire has died out.
3. The high mass of the firebox walls insulates the fire. This results in higher temperatures and more complete combustion.
4. The damper system allows better control of the fire.
5. Pots fit deeply and tightly into the stove. They are insulated from outside air. No smoke escapes.

The stove is built from a mixture of sand and soil. This mixture is called loreña. The word comes from the Spanish words for mud (lodo) and sand (arena). The loreña is applied in layers to form a solid block. The chimney hole, pot holes, tunnels, and firebox are then excavated before the loreña hardens.

Construction takes from six hours to several days. It depends on the size of the stove, weather conditions, and the skill of the builder.

## **Materials**

1. Clay or clay-soil. About 120 buckets are needed for one square meter.
2. Sand. About 120 buckets are needed for one square meter.
3. Water.
4. Sheetmetal.
5. Chimney pipe.
6. Material to make a base if one is desired. Some cultures prefer to cook as closely as possible to the ground. Others prefer to cook while standing. If so, a base is needed. Concrete blocks, adobe, rammed earth, bricks, or large rocks can be used. The best choice depends on local materials and the individual stove design.

## ***Tools and equipment***

1. Shovel
2. Spoon
3. Bucket
4. Machete or other large knife

## ***Construction***

### DESIGN

The size and shape of the stove can be changed for different families or cultures. Local traditions are very important. So are individual household patterns. Families use their cooking fires in different ways. Cooking pots may vary. Some cooks may prefer to cook food quickly at high heat. Others may prefer to cook more slowly at lower heat.

Information must therefore be collected on cooking patterns, the type of pots to be used, and the size and type of firewood or other cooking fuels. The best people to provide this information are those who will actually use the stove. The stove will not be used effectively unless they participate.

Here are some things to keep in mind during the design process:

1. Pots that need the most heat should be placed over the firebox. Pots needing less heat can be placed further down the tunnel system.
2. One pothole may fit more than one pot.
3. Try to keep the hot gases under the pots for as long a time as possible. This can be done by bending the tunnel sharply as it passes beneath each pot (see Figure 36).
4. The cook should be able to reach the pots and damper easily.



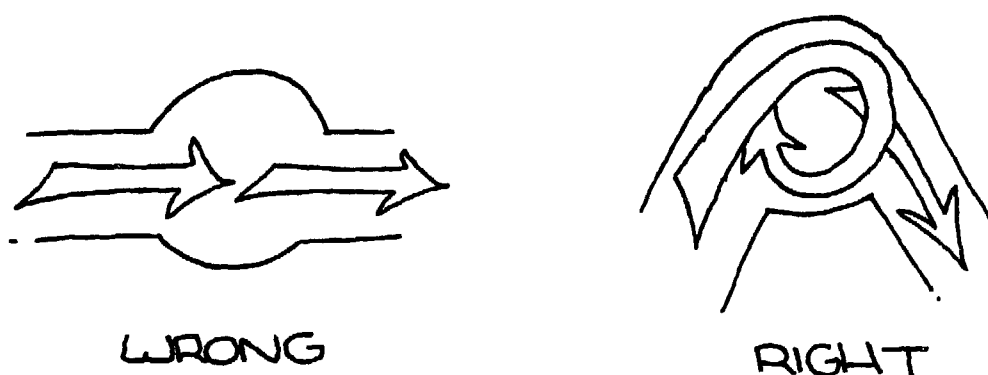

Figure 36

5. The size of the firebox should fit the amount of fuel that is needed.
6. The dimensions of the different stove parts should follow the guidelines in Figure 37.
7. Lorena melts in the rain. Provide for rain cover if the stove is built outside.
8. Long rectangular stoves crack more easily than other shapes.

### 1. The Lorena Mix

The lorena stove is made from a mixture of sand and clay (or clay-soil). Sand forms the main mass of the stove. The clay holds it together. Water is used to help the process.

Almost any type of sand will work. Coarse sand is best. Sand that is very coarse or that has gravel in it should be sifted through a screen with a 5mm (1/4") mesh. Ocean sands should be washed to remove salt.

It is more difficult to get the right kind of clay. Pure clay is best. Clay-soil can also work well. Clay-soil must be excavated to avoid top soil and organic matter (see Figure 32, page 51). Local potters and adobe makers can help you find the best local clay.

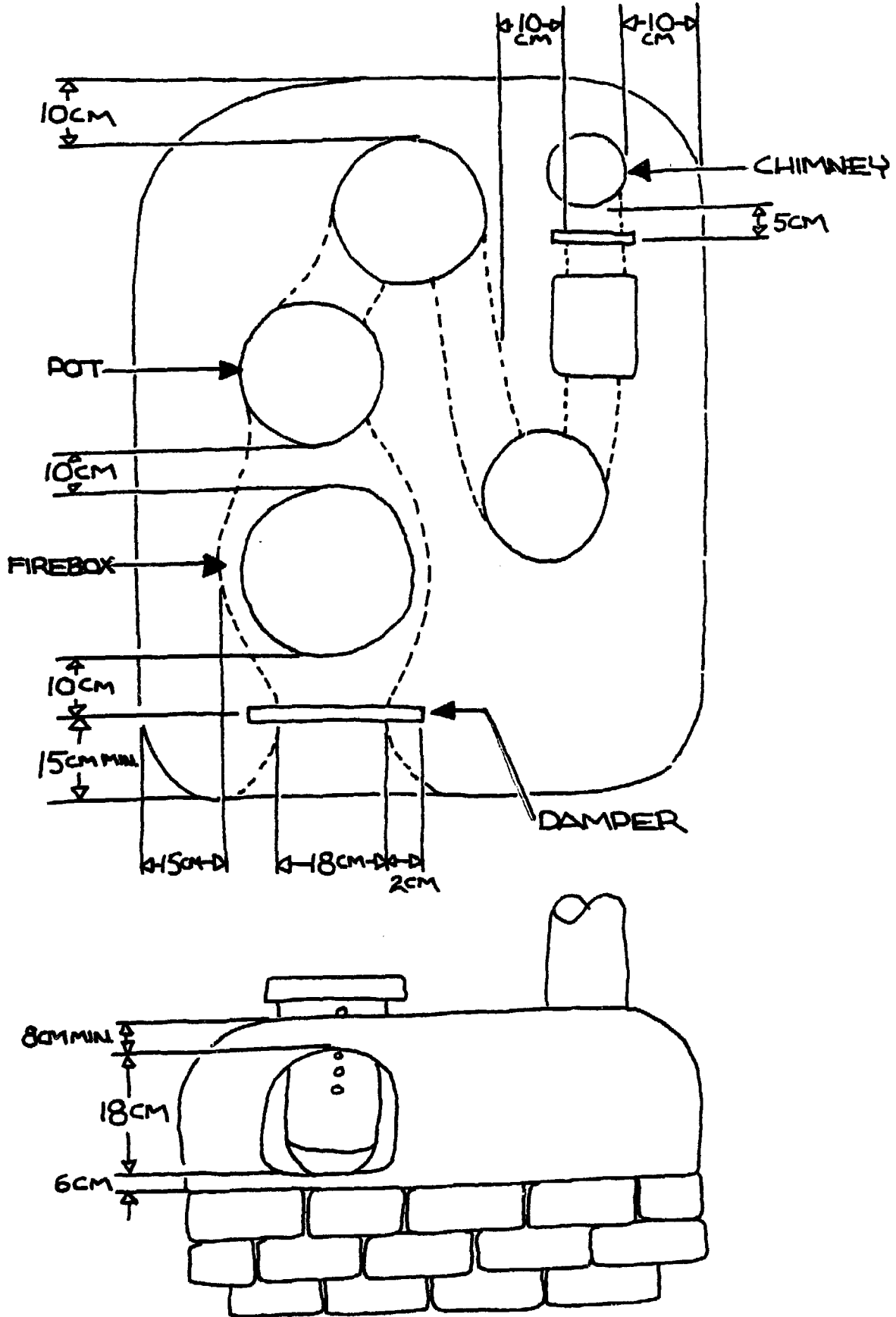

Figure 37

Soils can also be judged by the way they feel. Clay feels greasy. Sand feels gritty. Silt has a powdery feel. Try to avoid silt. It offers neither structure nor bonding.

There is an easy way to test a clay sample. First wet the sample until it becomes a stiff mud. It should be moist, but not watery. Roll the sample so that it resembles a 10cm long pencil or worm. Pick up this "worm" at one end with two fingers. Hold it parallel to the ground. It contains a lot of clay if it bends or sags without breaking.

The next step is to test whether the clay can stand a firing. Make a ball of damp clay. Place it in hot coals for an hour. Rub its surface with your thumb after it cools. It is no good if it flakes.

The next step is to find the best ratio of soil to sand. Test batches made with different ratios. The ratio for soil to sand should be between 1:1 and 1:3. The ratio for pure clay to sand should be between 1:3 and 1:5. Some clay soil will have a lot of silt. The silt does not help the clay hold the stove together. The clay may also have many lumps. If so, sift it first through a 5mm screen. You can also grind it with your feet.

It is best to mix the sand and clay when they are dry. Add water only after the mixing is finished. The water does not have to be clear. It can be murky. But it should not be salty.

An average stove with a top surface of one square meter requires about 1/2 cubic meter of lorena mix. Approximately 200 litres of water will be needed for the mixture. This quantity of water will probably fit into a 55-gallon drum.

There is a quick way to test whether the mix has the right ratio of sand to clay. Take a handful of the mix. Add enough water to make a patty in your hand. Press the patty slightly against the hand. Turn your hand over, palm down, with your fingers closed. Open your fingers slowly. The patty should fall away cleanly. If it sticks to your hand or leaves a lot of mix behind, there is too much clay. If it drops too quickly or

falls apart, there is too much sand. Adjust the ratio of sand and clay in the mix to adjust for the test results.

Another way to test the ratio in the mix is by making a series of test blocks. First check whether each mix has the right amount of water. Do this by making a hard packed ball in your hand. It should measure about 5cm (2") in diameter. Throw the ball 1m (approximately 3') in the air. Let it fall and hit your hand hard. Don't cushion it. The ball should stay intact. It is too dry if it cracks. It is too wet if it comes apart. Be sure that all the mix samples have the right amount of water. Next make the test blocks. Each block should be a rectangular form approximately 30-1/2 X 13 X 10cm (1' X 5" X 4"). Pound the blocks until each is good and hard. Use a rammed earth technique, if available. Remove the frame. Let the blocks dry completely. Test for strength, as shown in Figure 38. The strongest block makes the best stove.

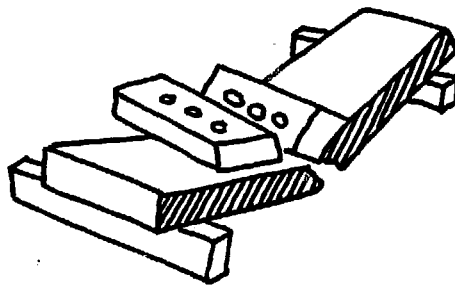

Figure 38

Another test is to make a small stove, start a fire, and watch for cracks.

## 2. Make the Base

A base is needed if people cook their food while standing. It can be made from a variety of materials so long as it is solid and does not shift. Concrete blocks, adobe, or bricks can be used to form a box. This is then filled with compacted earth. Other materials that have been used successfully include mortared rock, tree stumps, and even a heavy table. The base

should be designed with toe space. This lets the cook work closer to and more easily with the stove (see Figure 39).

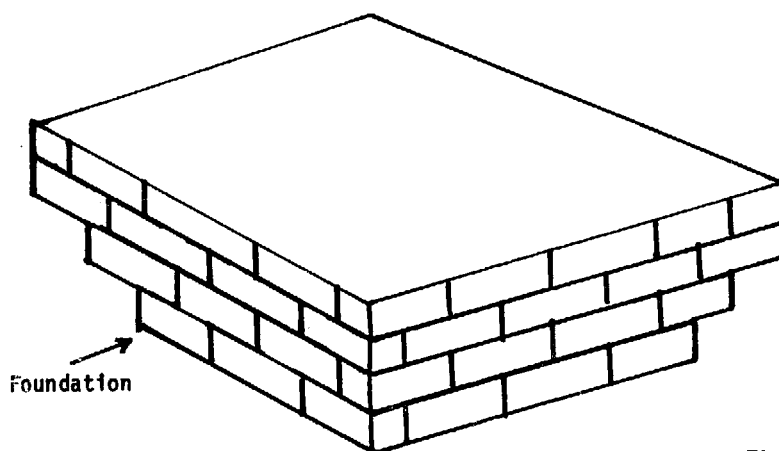

Figure 39

Mark the full size of the stove on the ground. Put the first layer of adobe blocks 10cm (4") in from the mark on the sides where the cook will stand (see Figure 40). The foundation can be laid using any cement or lorena mixture to hold the blocks together.

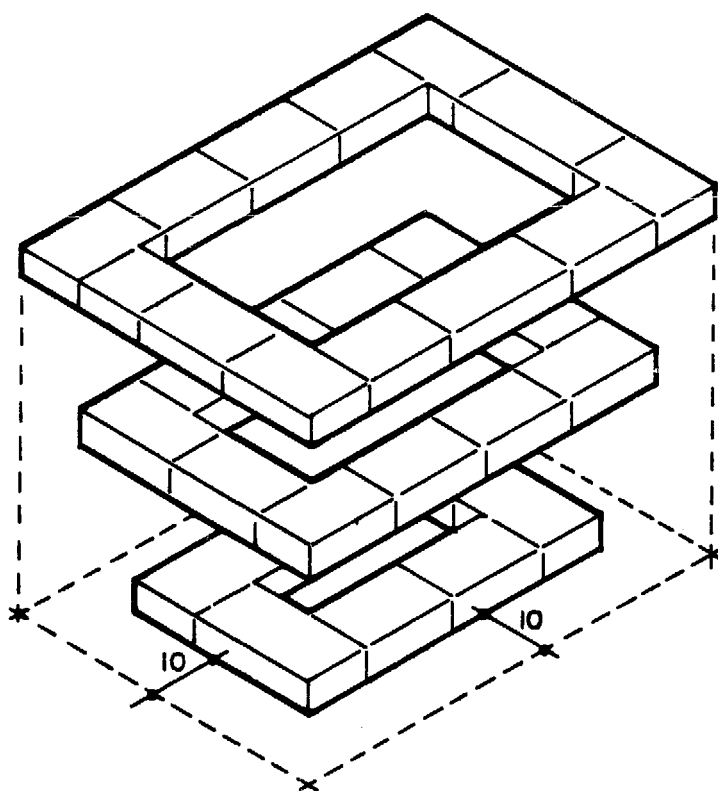

Figure 40

The upper layers should overhang by a total of 10cm (4") on the cook's sides to allow foot space for comfort while cooking. Build the foundation 40-45cm (16-20") high if the cook will be standing up (see Figure 41).

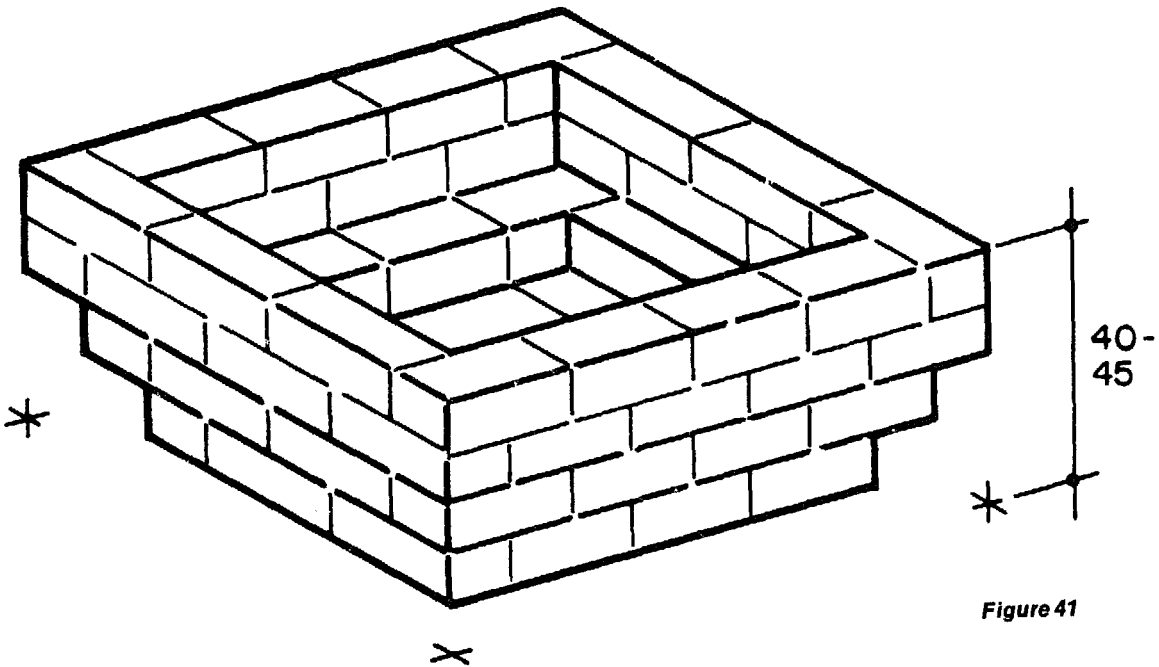

Figure 41

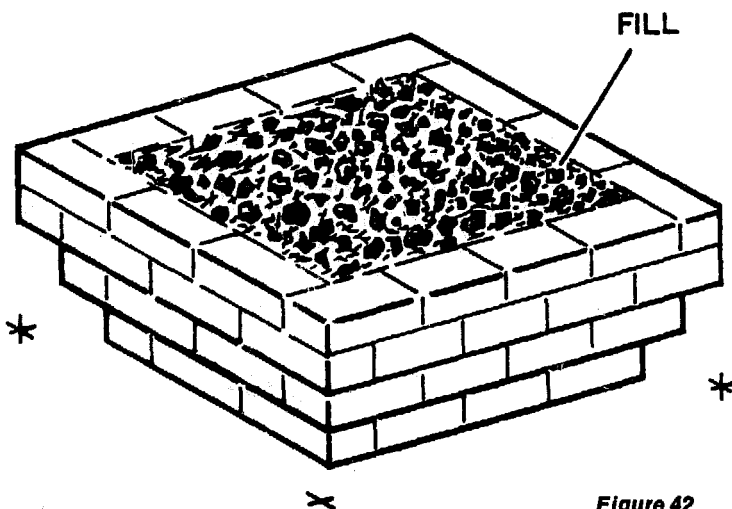

Figure 42

Fill in the center of the foundation (see Figure 42) with soil, rocks, broken adobe blocks, or debris. Pack the material down and allow the foundation to dry overnight.

### 3. Make the Stove Body

Mix and lay one layer at a time onto the base (see Figure 43). Use the tested mix. Pound the lorena in firmly with your hand, rocks, or a piece of wood.

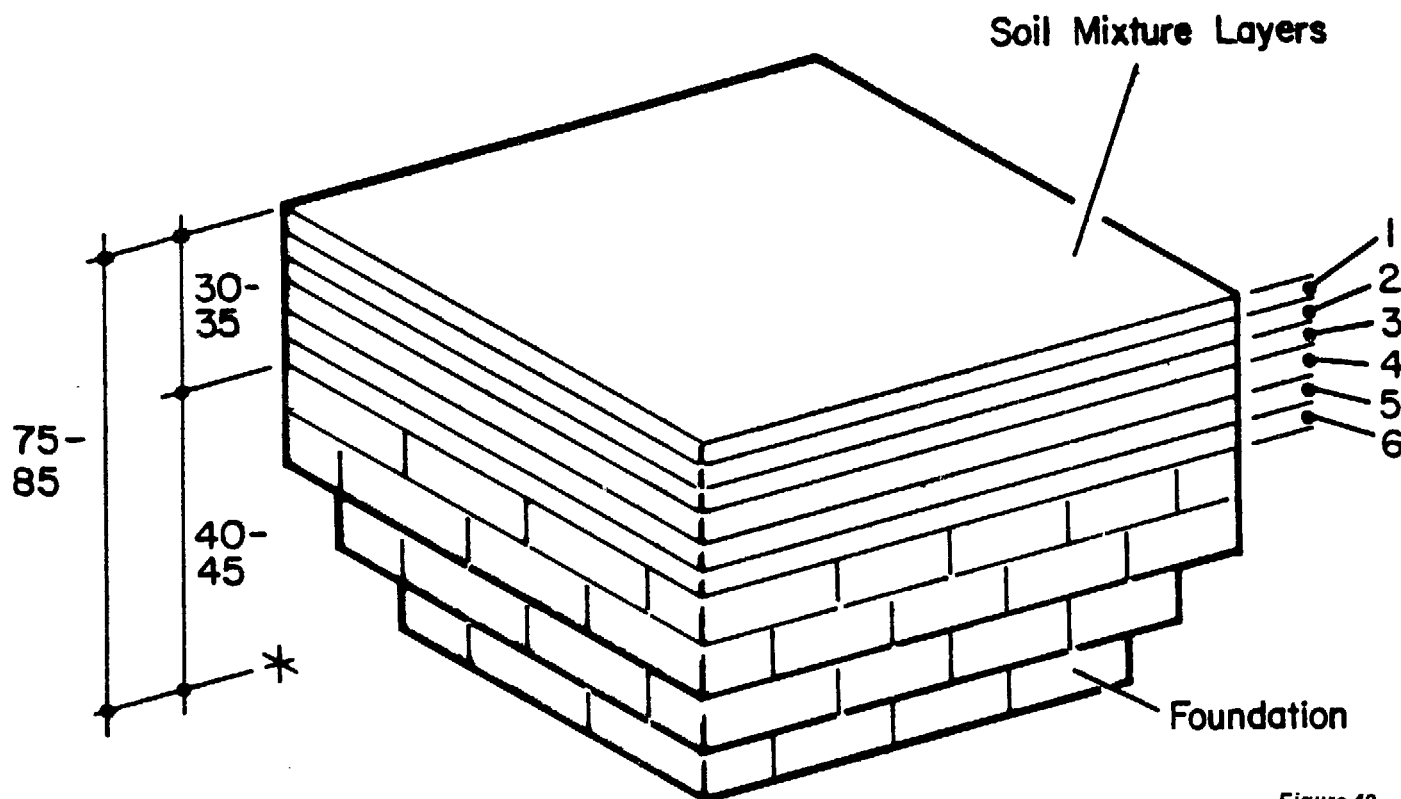

Figure 43

A finger pressed into the layer should go no deeper than 1cm (1/3"). (Use only the strength of the finger, not of the whole hand.)

Brace the side with your hand or a board when working near the edge (see Figure 44). Compress the edges well. These are areas that can cause trouble.

Allow each layer to dry and firm until you cannot push your finger in more than half the fingernail depth before adding the next layer. It may take as long as one day per layer if the stove is constructed indoors.

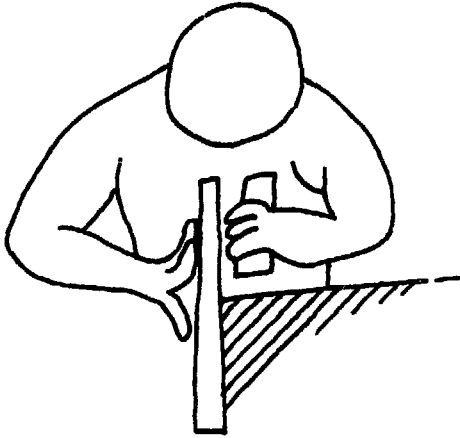

Figure 44

Watch each layer carefully. Add more sand to the next layer if cracks appear. Record any changes made.

Try to keep each layer level. Work a wetted board across the top of the completed stove in a zigzag motion. Cut away the high parts. Fill the small holes (see Figure 45). Use the machete or knife to even and smooth the sides.

If the lorena should crack as the pot holes and tunnels are dug, fill the cracks with wet lorena. If cracks appear all the way down through the stove, demolish the stove. Break the lorena up and start again. (Cracks are due either to overworking the lorena when the layers are applied, cutting the tunnels when the layers are too wet, or to too much clay in the mix which causes uneven shrinkage of the layers as they dry.)

#### 4. Mark Stove Layout

Draw the outline of the desired layout on the stove body. Make the outlines slightly smaller than the hole needed. Figure 37 (on page 60) shows one possible stove layout. Local conditions may demand different designs.



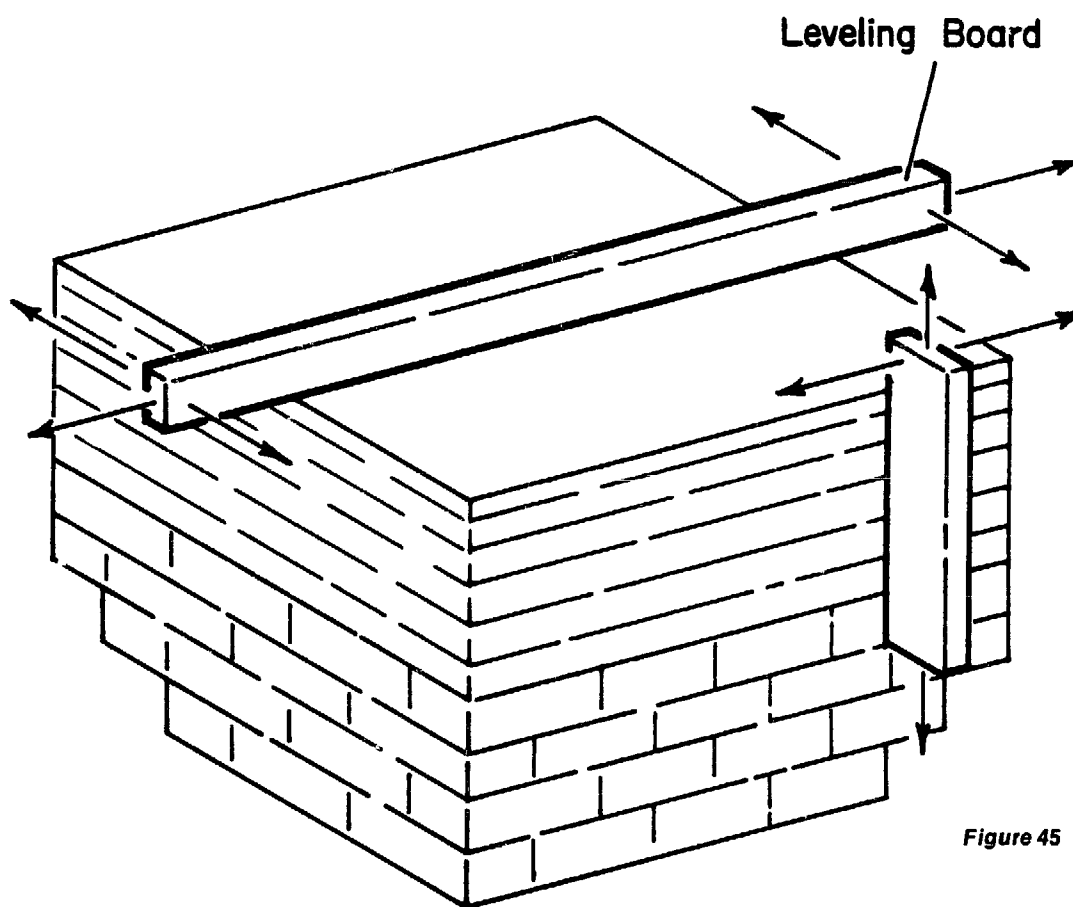

Figure 45

### 5. Excavate Stove Holes

First make sure the stove body is dry enough. If you cannot push your finger in more than 1cm (1/3") (see Figure 46), the stove is dry enough to cut.

All tools used from now on must be wet. Holes made in the lorena should be sliced, not stabbed. Holes under the pots should go about halfway through the stove.

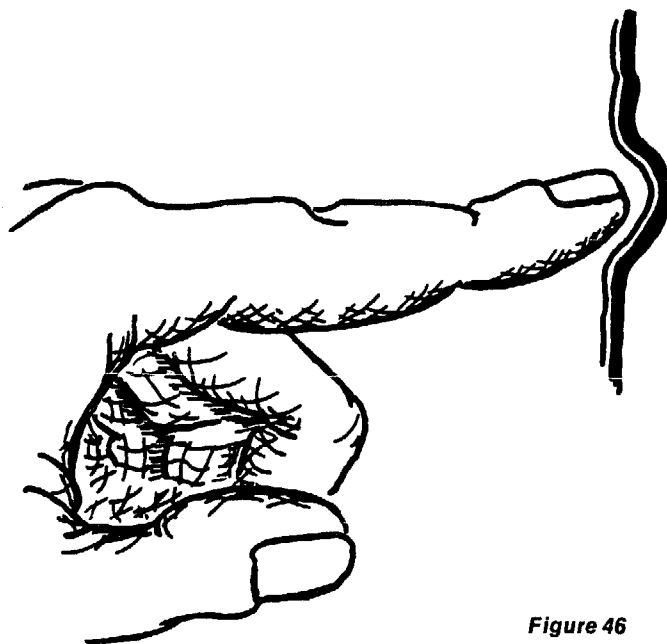

Figure 46

Slice small holes down the center of each pot hole and the chimney hole. Use a spoon or knife for digging. Keep all cutting tools wet.

Cut the damper slots with a machete or large knife. One damper is the firebox door. The other two are located on either side of the waterbox hole (see Figure 37 on page 60). Cut perpendicularly into the stove surface, straight down into the block. Each cut should be about 1cm (1/3"). Let the water on the blade loosen the lorena before cutting.

Let the stove dry until the stove body is very firm throughout.

#### 6. Complete Cooking Holes

Plan carefully: one hole can be made so that several pots may be used on it (see Figure 47). Use a spoon and the pots themselves to enlarge and shape the hole. Work carefully.

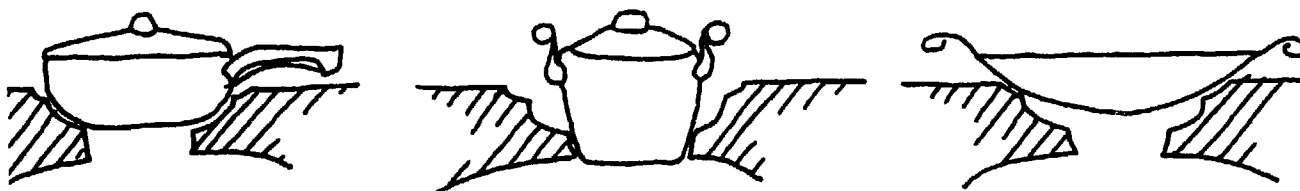

Figure 47

Begin cutting with the spoon. Then wet the sides of the pot to be used on that hole. Twist the pot back and forth without any downward pressure. Look at the pattern made by the movement of the pot to see where the hole should be enlarged. Work slowly and carefully, until the pot fits down snugly into the hole.

#### 7. Complete Firebox

Shape the entrance in the form of an arch. The arch should be higher than it is wide, but not more than 20cm (8") wide. Also arch all tunnels and the top of the firebox. This helps distribute the weight and prevents lumping or cracking.

Flare the firebox entrance so that wood can be loaded more easily.

#### 8. Complete Waterbox Hole

Use a machete and a pot or empty can to dig out the waterbox hole. Dig the hole about the same height as the container you will use for water.

#### 9. Excavate Tunnels

Use the spoon to dig out tunnels connecting the firebox and the pot holes (see Figure 48). The tunnels must allow the hot air inside the stove to circulate as freely as possible.

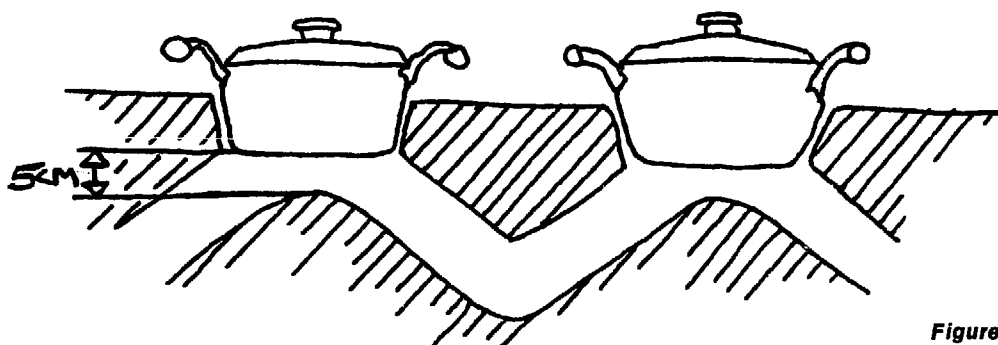

Figure 48

Make the tunnels at least large enough to accommodate a hand holding three chicken eggs. The tunnels should rise to the pots. Make the section of the tunnel below each pot hole shallow enough for only three fingers to fit between the pot and the tunnel floor. After finishing the tunnels, build up the floor beneath the pots using clay that was dug out when making the tunnel.

#### 10. Add Chimney

Make sure the hole for the chimney is deeper than the tunnel inside the stove. This gives added space so that the air passage is less likely to get clogged up with fallen debris.

Place a chimney pipe into the chimney hole. Sink it 15cm (6") into the block. If the chimney needs support, put nails into the lorena where the chimney should rest inside the stove. The nails may not be necessary if the chimney fits very tightly and remains steady.

Add another chimney pipe. The higher the pipe, the better it draws air to the stove. Lorena stoves seem to need at least 183cm (6') of chimney to operate efficiently.

If the stove is constructed inside a building, the chimney should be at least 80cm (32") higher than the highest point of the roof to ensure good draft.

#### 11. Make the Dampers

Use scrap sheet metal and make the dampers as shown in Figure 56 on page 81. Each damper should be a little wider than the tunnel so that it can be used to control the flow of air through the tunnel.

Rounding off the bottom edges of the dampers will allow easier movement of the dampers inside the stove.

#### 12. Finishing Touches

Fill cracks with fresh lorena that is pounded in well.

Complete the body of the stove by lightly splashing water on the sides and top and running the machete, knife, or scrap metal over the surfaces until they are smooth.

When dry, apply whitewash, plaster, or varnish, as desired.

### **Use of the stove**

1. Put pots in place. Make sure all the pot holes are covered and waterbox pot is filled and in place.

2. Open damper doors.
3. Place kindling just inside the firebox damper door and light.
4. Close firebox damper and adjust waterbox dampers for draft. The stove is now ready for cooking.
5. Slow fire down and conserve heat by lowering damper doors.

For slow cooking:

1. Pull coals forward and add a large piece of firewood.
2. Pour in a bucketful of sawdust.
3. Close damper doors and begin to cook.

The lorena stove is easy to maintain. If the stove stops drawing, the tunnels or chimney pipes need to be cleaned.

## **Smokeless chula**

This chula (see Figure 49 on the following page) is based on the findings of S.P. Raju and the Hyderabad Engineering Research Laboratory. Raju's book, "Smokeless Kitchens for the Millions," was first published in India in 1953. Since then his chula, and variations on the basic design, have undergone extensive testing and are in widespread use.

The chula is virtually smokeless, and cuts firewood use by as much as 40 percent over an open fire. The materials--clay and sand and bits of scrap metal--are generally abundant and usually free. Construction is simple enough that almost anyone could build the stove. This particular model has three pot holes, and provides for hot water without the use of additional fuel.

# SMOKELESS CHULA

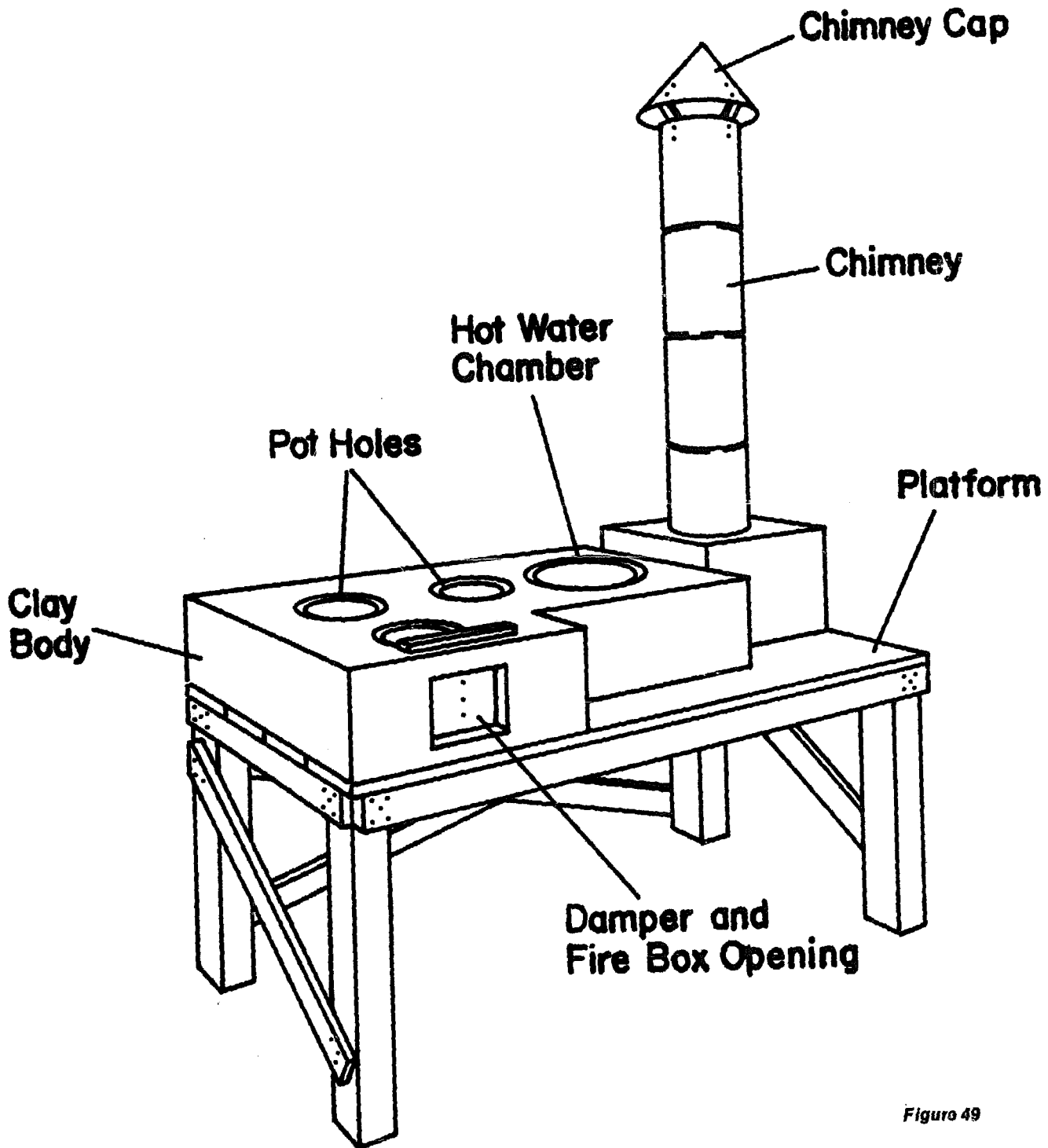

Figure 49

The stove can be built on the floor in the traditional manner, but many cooks are finding that they prefer the convenience and safety of a stove that is about waist high.

A stone, brick, or concrete platform can be used to hold the stove. A table may be convenient, but remember that the chula may weigh more than 200 pounds so be sure the table is very sturdy. Space under the table or platform can be used to store fuel wood, cooking utensils, or other goods.

## **Materials**

- . Clay--about 200 lbs.
- . Sand, sawdust, and cow dung (proportions vary, but a 3:1 clay/sand mixture has worked well)
- . Lumber--for the platform and forms (if desired)
- . Scraps of tin, bailing, pieces of wire--to reinforce various parts of the stove and to make dampers
- . Drain tile, round roofing tile, tin cans, or commercial stovepipe--for the chimney
- . Brick or stone--for the platform portions of the stove, and for the chimney if necessary

## **Construction**

### **1. Make the Platform or Stand**

If you choose to construct a platform or stand, the following directions may prove practical (see Figure 50). Dimensions here are given in rough metric, followed by inches in parentheses.

Prepare four thick pieces of wood 10cm X 10cm X 60cm (4" X 4" X 24-1/2") for the legs.

# PLATFORM

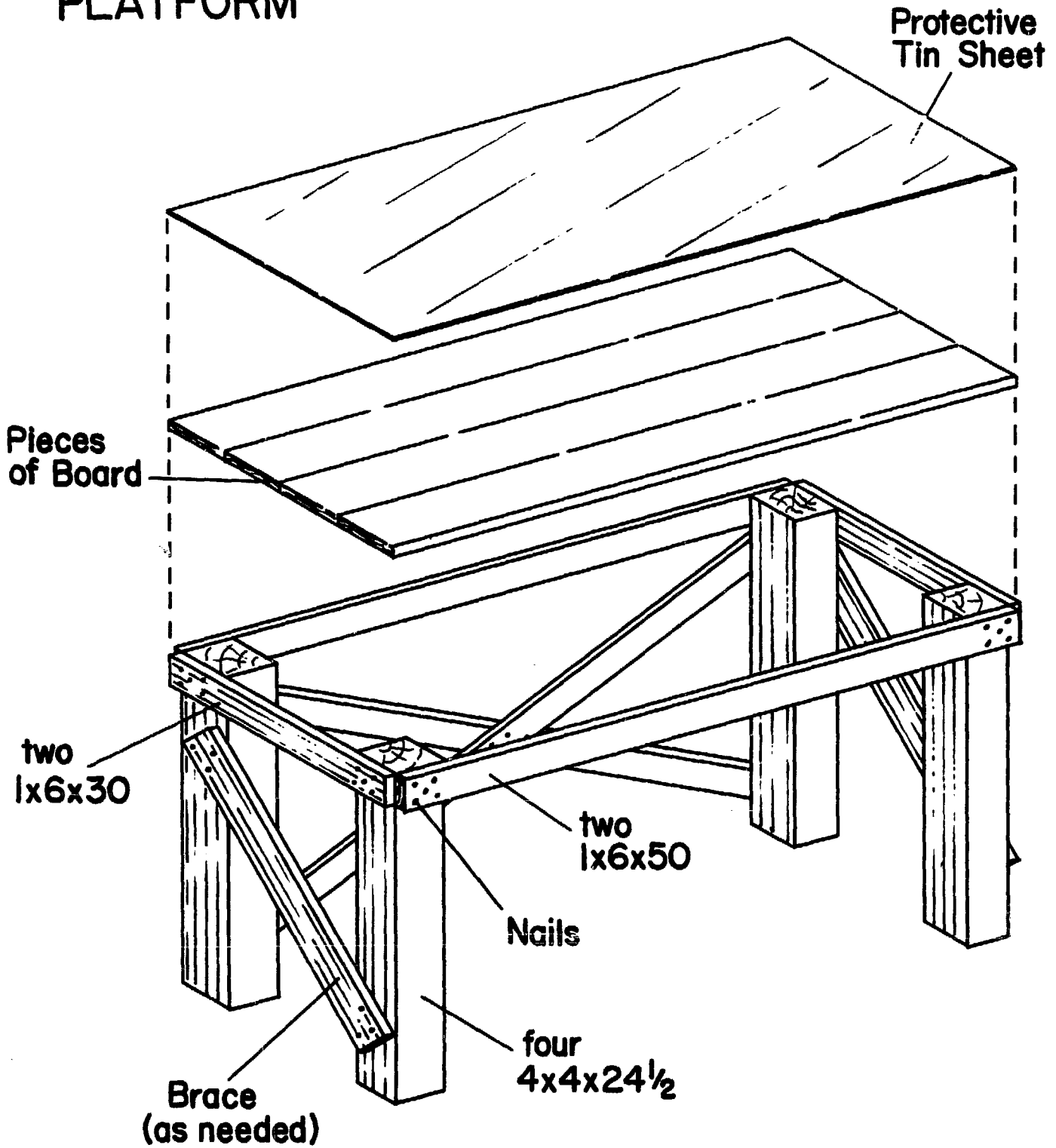

ALL DIMENSIONS IN INCHES

DO NOT SCALE DRAWINGS

Figure 50



Get two long boards 2-1/2cm X 15cm X 125cm (1" x 6" X 50") and two short boards 2-1/2cm X 15cm X 75cm (1" X 6" X 30").

Nail the first two legs to the extremities of each short board.

Connect these two structures with the long boards, nailing them well to each side. This will form the structure for the stand. Brace table legs with diagonal boards as shown.

Prepare pieces of board to fit the dimensions of the table top. Nail them firmly to the frame. This platform or stand may be covered with a tin sheet for more protection against the heat of the stove.

## 2. Make the Form

The clay will be easier to work with, and the finished chula will look better, if a form is made to mold the clay. If lumber is unavailable or expensive, the form can be eliminated.

The chula itself will be 15cm (6") high, the chimney base will be 20cm (8") high. For the form for the chula use boards that are 15cm (6") wide; for the chimney base use 20cm (8") boards.

Following the dimensions in Figure 51, fasten the boards together firmly enough to hold the weight of the clay, but loosely enough to be removed easily.

## 3. Make the Chimney

Make the chimney before beginning the stove (see Figure 52). Round tin cans, 15cm (6") in diameter, can be fitted one on top of the other, or may be soldered together to form the chimney. Drain pipes or round roofing tiles can also be used. In some places it may prove practical to pack prepared earth around a pipe of suitable diameter, which is withdrawn afterwards. Galvanized sheets, asbestos, or cement pipes can also be used.

The chimney should be about 3/4m (2-1/2') higher than the highest point of the roof. A cowl or cap on top of the chimney

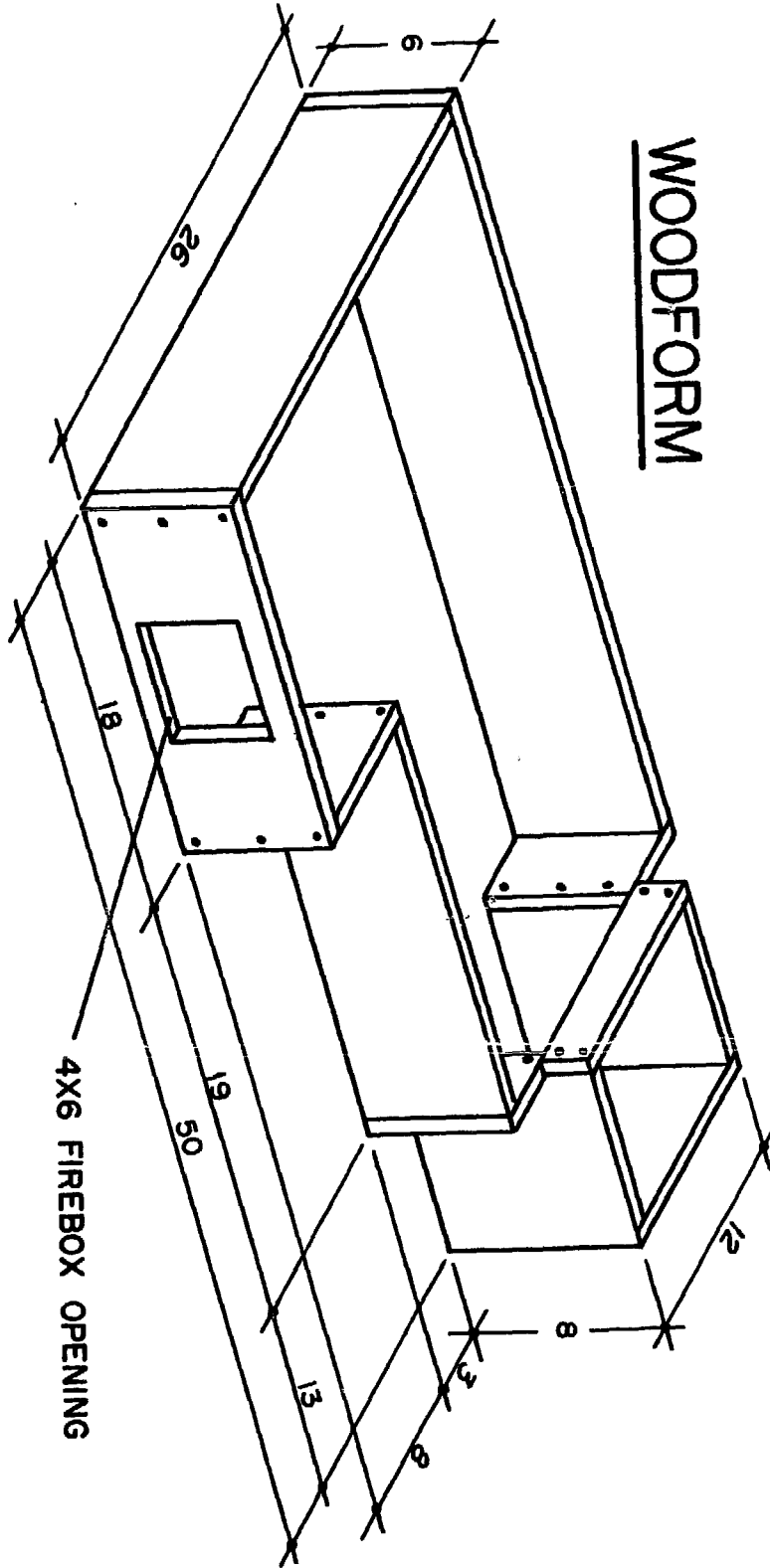
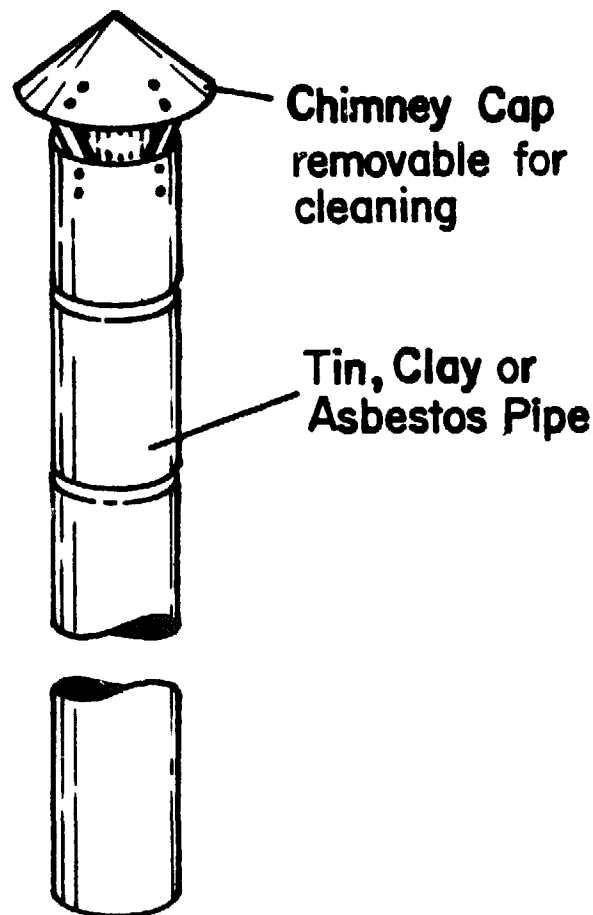

Figure 51



Chimney

Figure 52

to prevent the entry of rainwater may be made of tin for pipe chimneys, or of flat stone or flat asbestos for masonry chimneys. The cowl must be removable for cleaning the chimney.

4. Draw the Stove Plan

Put the form in place on the stand and draw a plan of the stove directly on the stand. Use the dimensions in Figure 53 as a guide.

5. Prepare the Clay

Soak the clay in water overnight.

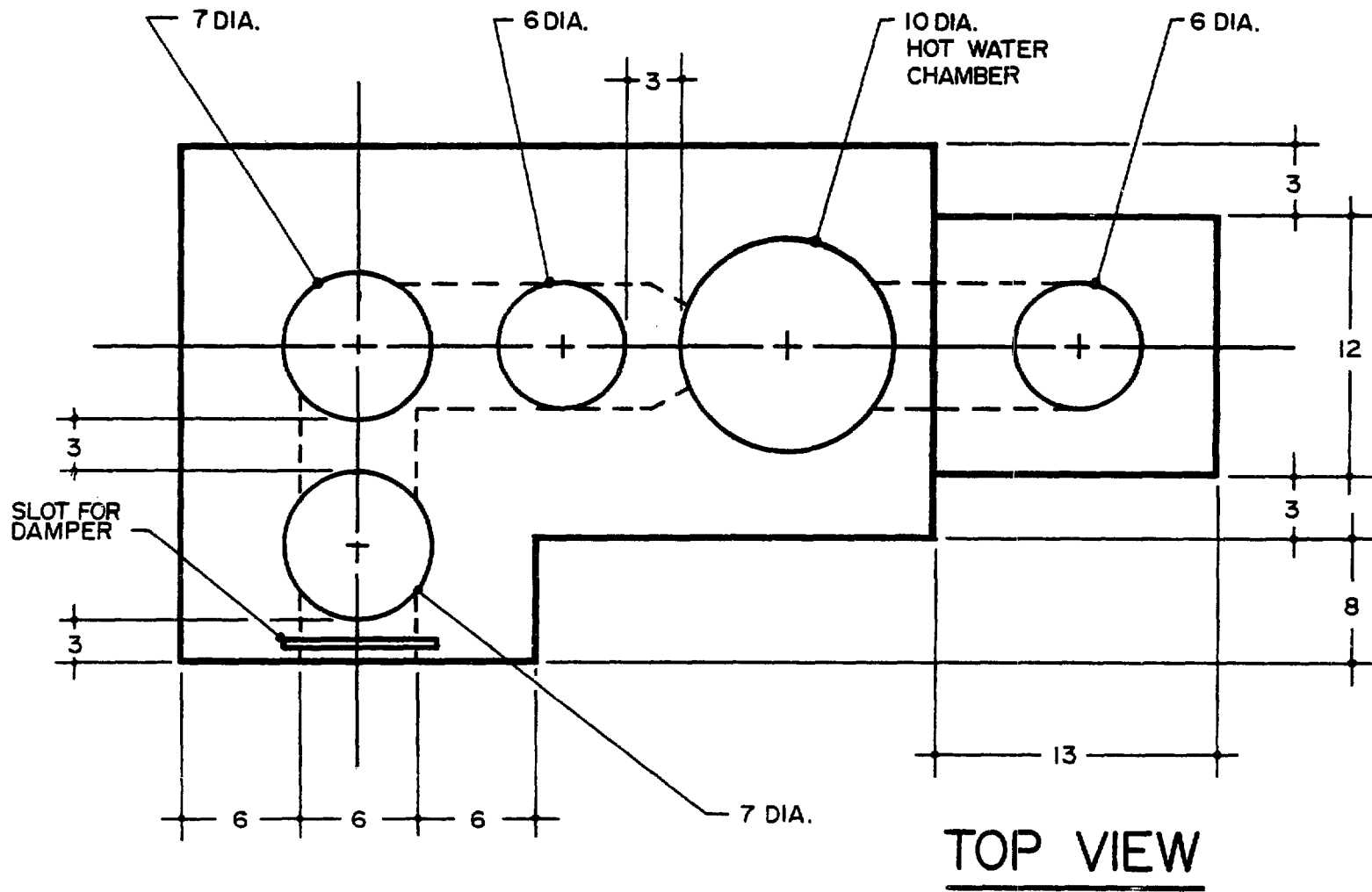

Next day, take off the water and mix the clay well with sand, sawdust, or cow dung. Three parts of clay to one part of sand has proved a good mixture.

Knead it very well and cover with moist sacks.

Let it stand overnight.

(Bricks can be used in building the walls of the stove. In this case, less clay will be needed.)

#### 6. Make the Stove

Start with the base of the fire duct (channel for heat and air), by putting down a layer of clay. The base slopes from 2.5cm (1") thick at the front to 7.5cm (3") thick at the last pot hole (see Figure 54). Beneath the hot water chamber and at the base of the chimney, the floor of the duct drops to 2.5cm (1") thick again.

Build the walls around the duct 12.7cm (5") high. Start building the wall to hold the chimney. Continue building up the clay around the fire duct to a depth of 12.7cm (5"). Place a block of clay in the center of the hot water chamber. This will support the hot water pot without blocking the duct.

Fill the fire duct space with sand. If you are not using a wooden form, cover the firebox opening with a piece of wood, cardboard, or metal to keep the sand from spilling out.

Set the chimney in place. Be sure it does not slip down and block the duct.

Put down a 2.5cm (1") thick layer of clay for the top of the stove. Scrap metal strips or heavy wire may be used to reinforce the stove top between and around the pot holes (see Figure 55). Cut out the pot holes with a wet knife. Shape the pot holes to fit the pots. This can be done by setting a wet pot in place and gently turning it back and forth until the pot hole conforms to the bottom of the pot. Remove the pot.

# CLAY BODY

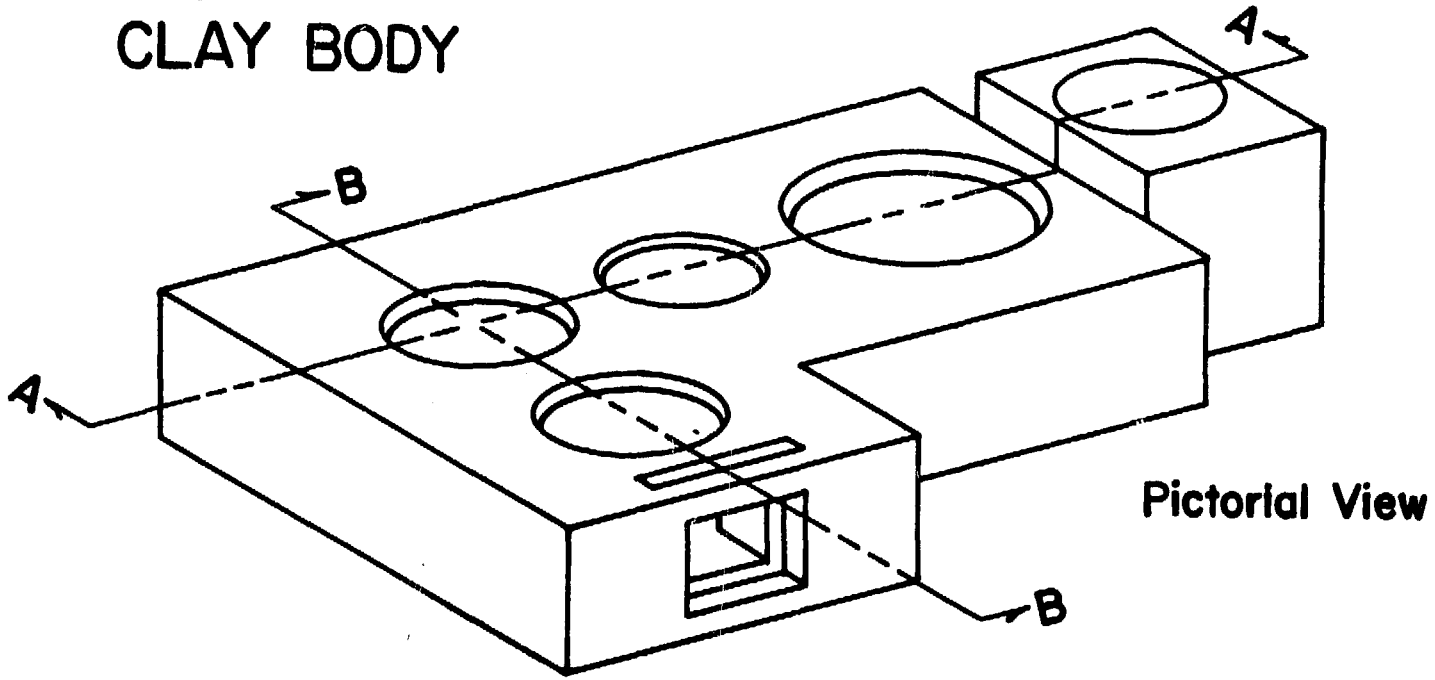

See Detail "A"

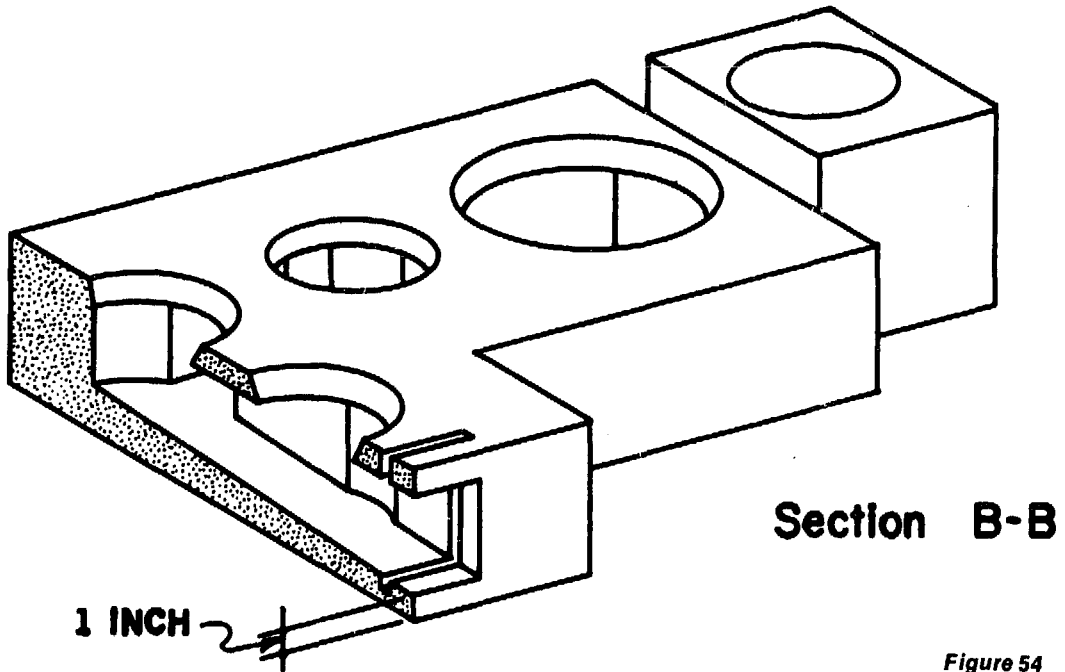
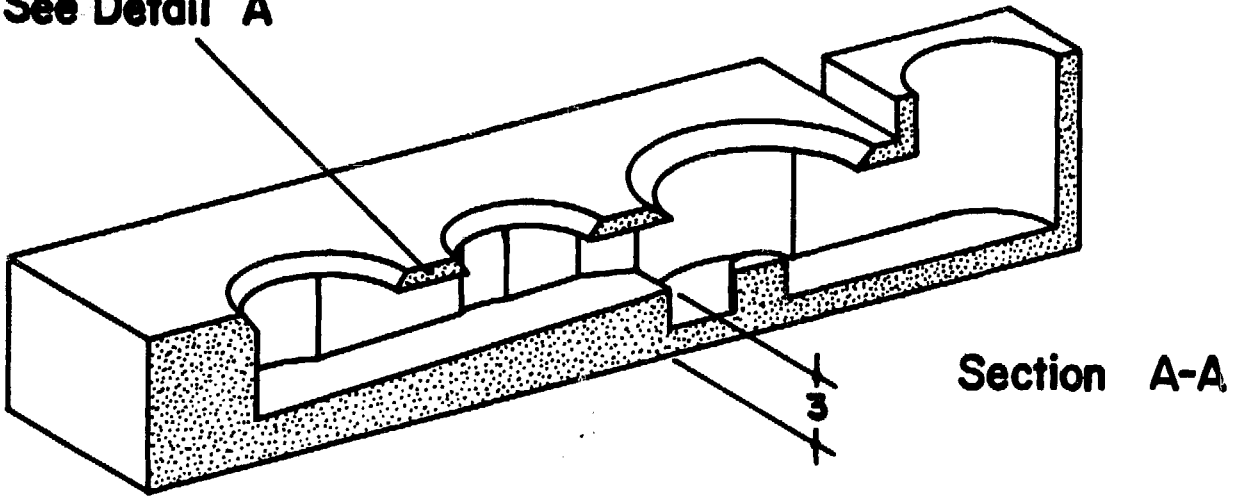
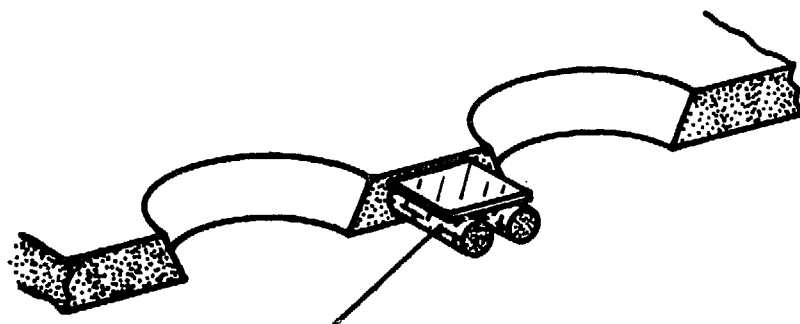

Figure 54



**Reinforce Roof  
With Hard Material  
(Iron, Tile, etc.)**

*Figure 55*

Cut a slot for the damper with a wet knife. Make the slot just a little wider than the fire duct (about 1.25cm [1/2"] on either side).

To make the damper (see Figure 56), cut a 15cm X 17.5cm (6" X 7") rectangle out of sheet metal. Nail thin wooden strips along

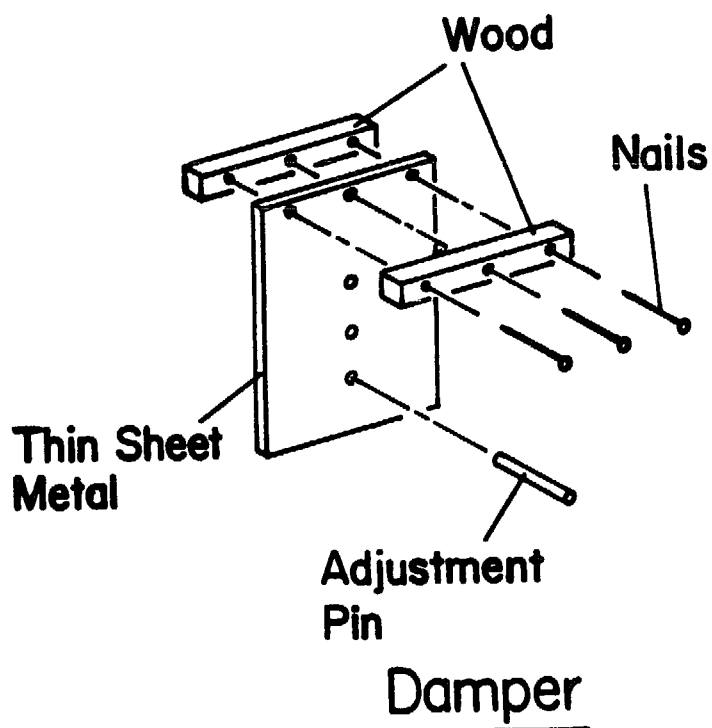

*Figure 56*

one short edge as shown. Punch two or three holes in a vertical row down the center of the damper.

To use the damper, slide it into the slot. Adjust the opening by inserting a nail through the appropriate hole. (Be careful. The nail will get hot.)

Build up the chimney base to a depth of 20cm (8"). Smooth the surface of the clay with water. Cover the chula with damp sacks and allow it to dry. When the stove is dry, remove the wooden forms and sweep out the sand.

Mend cracks that have developed during the drying process by moistening the surface of the cracks and filling in with the clay mixture.

### **Use of the stove**

To lay the fire, first make a base of wood shavings, other available tinder or crumpled paper, and then add small pieces of wood. Put larger wood, chopped to size, on top. Light the fire, and leave the firebox open until the fire is going well. For higher heat, open the damper. To lower the heat, half close the damper. To put out the fire, close the damper completely.

Pans should fit the cooking holes closely. The base of the cooking utensil should be 3-5cm (1-2") below the surface of the hole. Be sure all pot holes are covered when the stove is in use. Use a pot lid or a piece of metal.

Keep the stove clean. Cover all pot holes before removing ashes from the firebox. From time to time it may be necessary to coat the stove with a thin slurry of clay and water to clean it. Cracks and chips can be mended with the same kind of clay/sand/water mixture that the stove was made of.

Clean the chimney regularly--about every four to six months. This lessens the danger of chimney fires due to creosote buildup, and prevents the chimney from clogging.



## **Singer stove**

The Singer stove (Figure 57) is an efficient, relatively smokeless cooking stove similar to the smokeless chulas of India. It can be molded in clay, or built of either sun-dried or burned bricks. The molded stove has a life expectancy of about a year; the sun-dried brick construction will last much longer. A burned-brick stove is the most expensive alternative, but will last for many years. Because the sun-dried brick construction is more durable without being much more costly, directions are given here for using this material.

The stove can be built to any height and with two or more pot holes. The stove can also be built with either a straight or bent flue. With a straight flue, the stove requires somewhat more room, but it is cheaper and easier to build.

Careful consideration should be given to the position of the stove. Even the smaller versions are quite heavy and difficult to move once in place. Because the stove is virtually smokeless it can be used indoors. With suitable protection from the rain, it can also be used out-of-doors.

Detailed instructions are given for the construction of a waist-high stove with three pot holes and a straight flue.

### **Materials**

- . Clay
- . Ashes or sand
- . Sawdust, rice hulls, straw (if desired)
- . Water
- . Lumber and nails for the forms

Approximately one-half cubic meter of material will be required for a waist-high cooker with three pot holes.

The proper proportion of dry materials will depend on the type of soil in a given area and the local manufacturing methods. It

SINGER STOVE

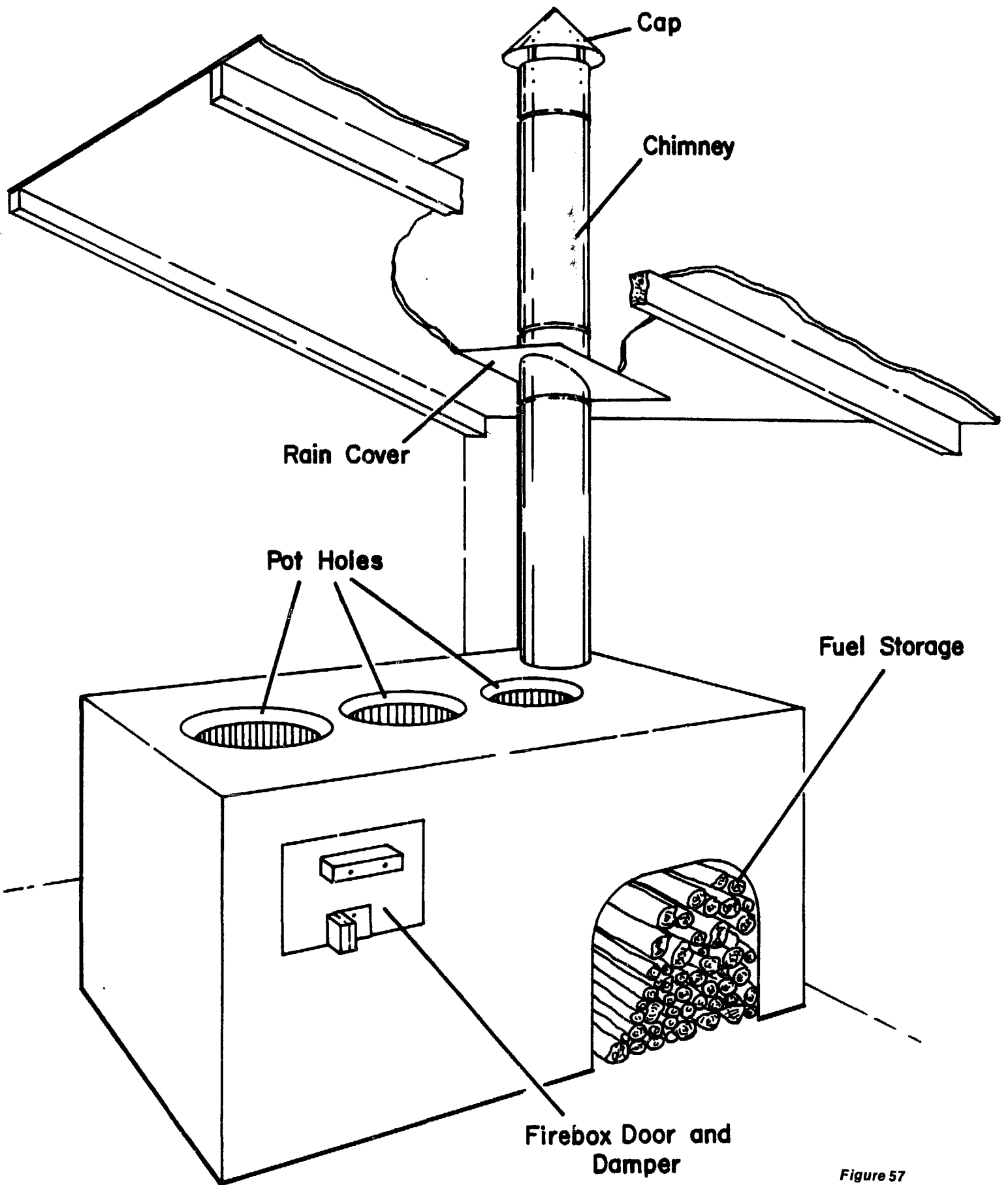

Figure 57

may be best to experiment with several mixtures to see which one will make the best blocks. In some areas a mixture of three parts clay to one part sand is used. In other areas, ten parts of clay are mixed with one part of finely cut straw. When experimenting, be sure to keep careful records so that a good mixture can be duplicated easily.

The clay should be broken up and crushed, and sifted through a wire screen to remove large rocks, sticks, and other material. Mix the dry ingredients thoroughly before adding the water. Add just enough water to make a mix that is pliable enough to be worked easily but firm enough to hold its shape. Mixing can be done with a special mixer, a heavy wooden paddle, or by treading on the mixture.

## **Construction**

### 1. Make the Forms

With straight, smooth lumber construct a form for the plates for the cooking surface (see Figure 58). Suggested dimensions for a finished plate are 5.5cm (2") thick X 34cm (13-1/2") long X 27cm (11") wide, but these may be adjusted to suit special requirements. The form consists of a base plank, the central form, and a top plank. The form may be fitted with hand grips to assist in lifting it away after the plate is made. Before the clay mixture is put into the form, sprinkle the inside with ash dust to ensure that the finished plate will slide out easily without sticking.

Press the clay mixture into the form. Allow to dry slightly.

Carefully mark the cooking hole and cut it out with a wet knife or other sharp tool. The suggested diameter of the hole is 20cm (8"), but this may vary according to special requirements, such as the size of the pots to be used. It will be necessary to make two or three burner plates depending on the style of stove you choose. The holes for the pots can all be the same size, or can be different sizes to accommodate a variety of pots.

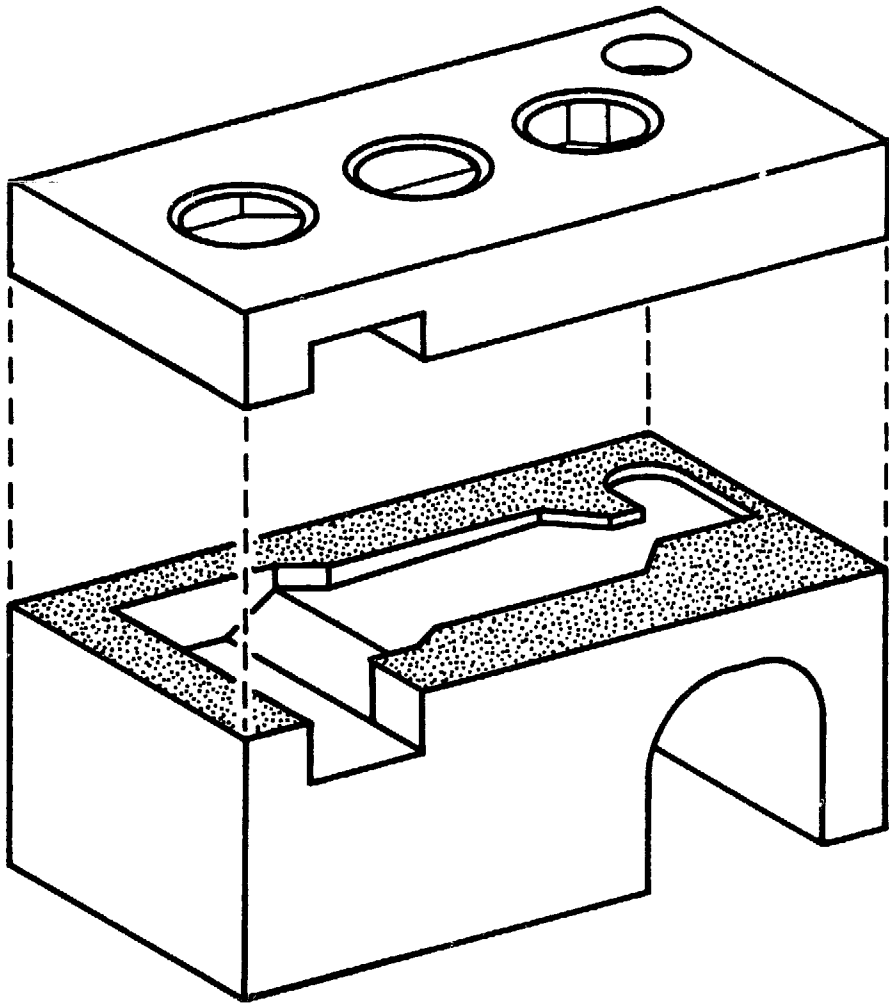

Plan View

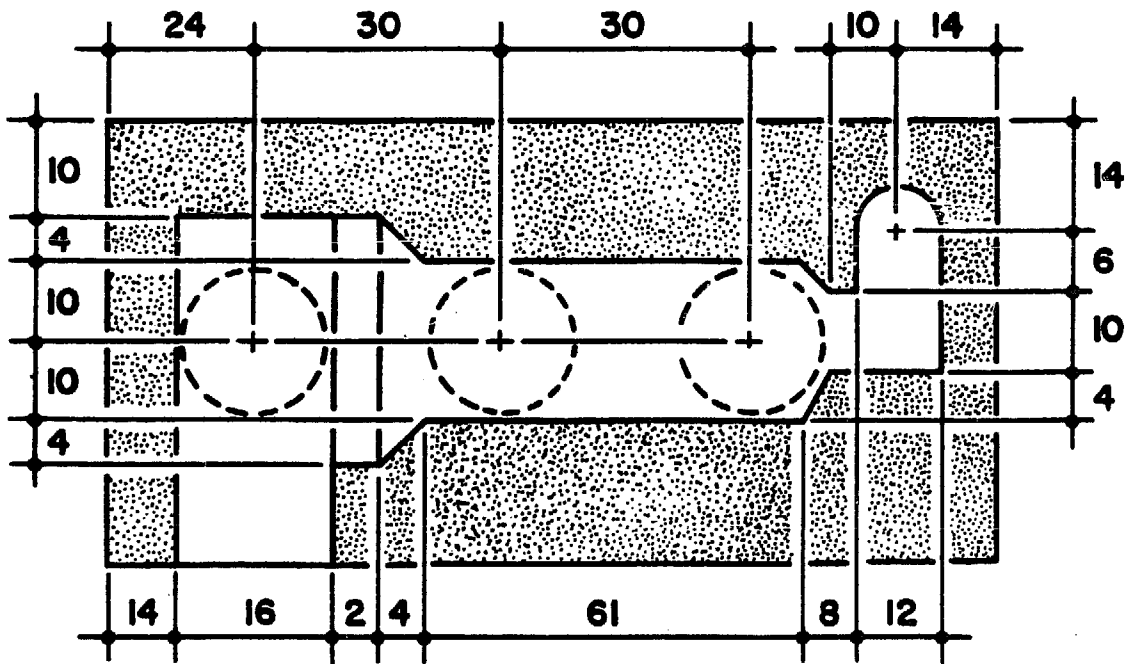

All Dimensions in Centimeters

Do Not Scale Drawing

Figure 58

Construct a form to make the bricks, similar to the plate form described above. Suggested dimensions for a finished brick are 5cm (2") thick X 10.5cm (4-1/4") wide X 22.5cm (9") long, but the dimensions may be adjusted to suit special requirements. Approximately 300 bricks of this size will be needed. The process for forming a brick is the same as that for forming a plate.

A form will also be needed for the firebox door (see Figure 59). Make it so that the finished block is 14cm X 15cm X 5cm (5-1/2" X 6" X 2"). There should be an opening 4cm high X 6cm wide (1-1/2" X 2-1/2") along one 15cm (6") edge. This opening is for the damper. See the section Make the Firebox Door for directions for finishing this block. The damper must be attached while the clay is still damp.

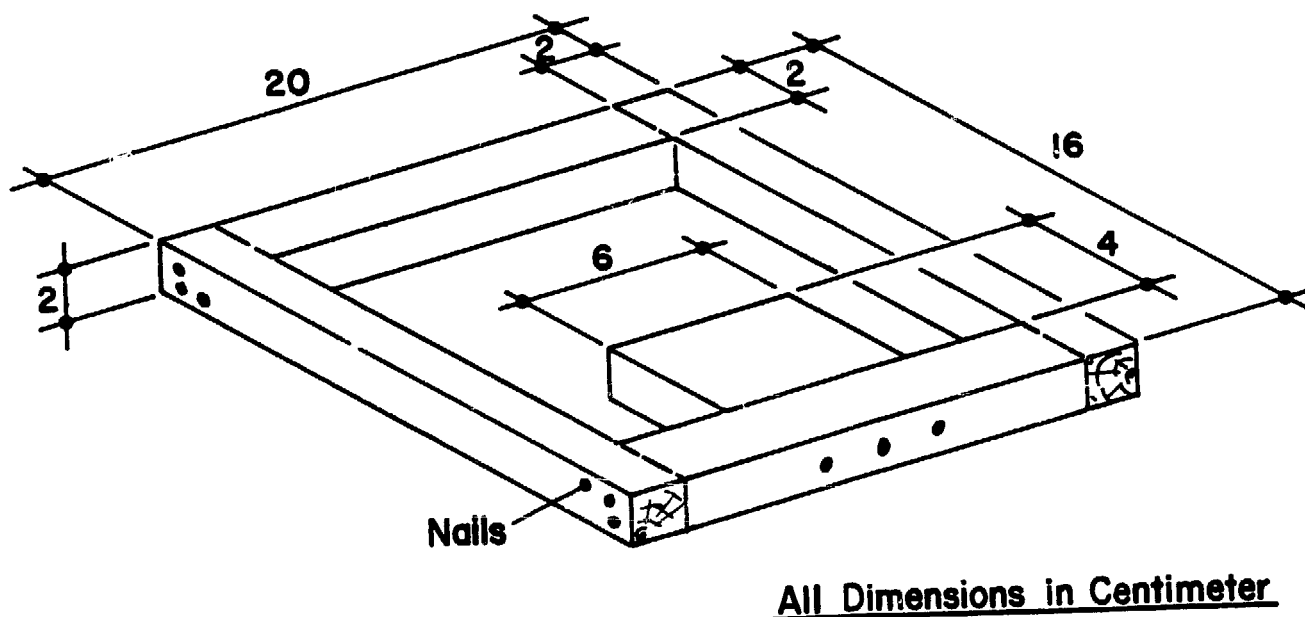
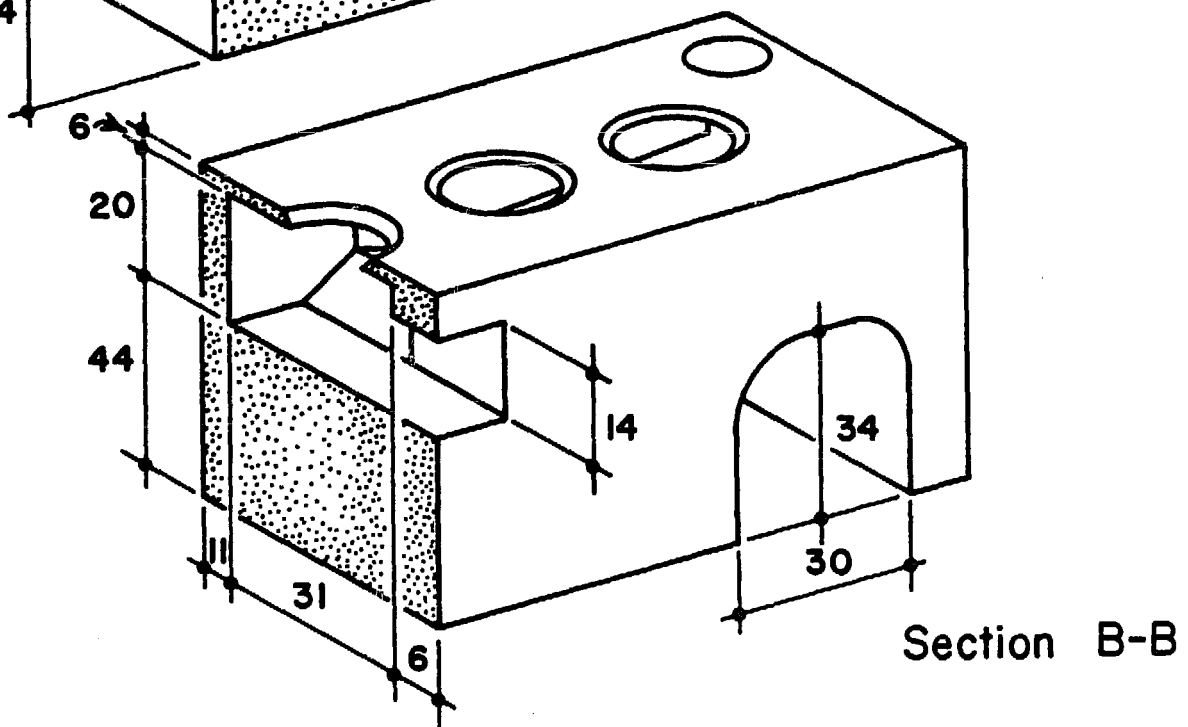
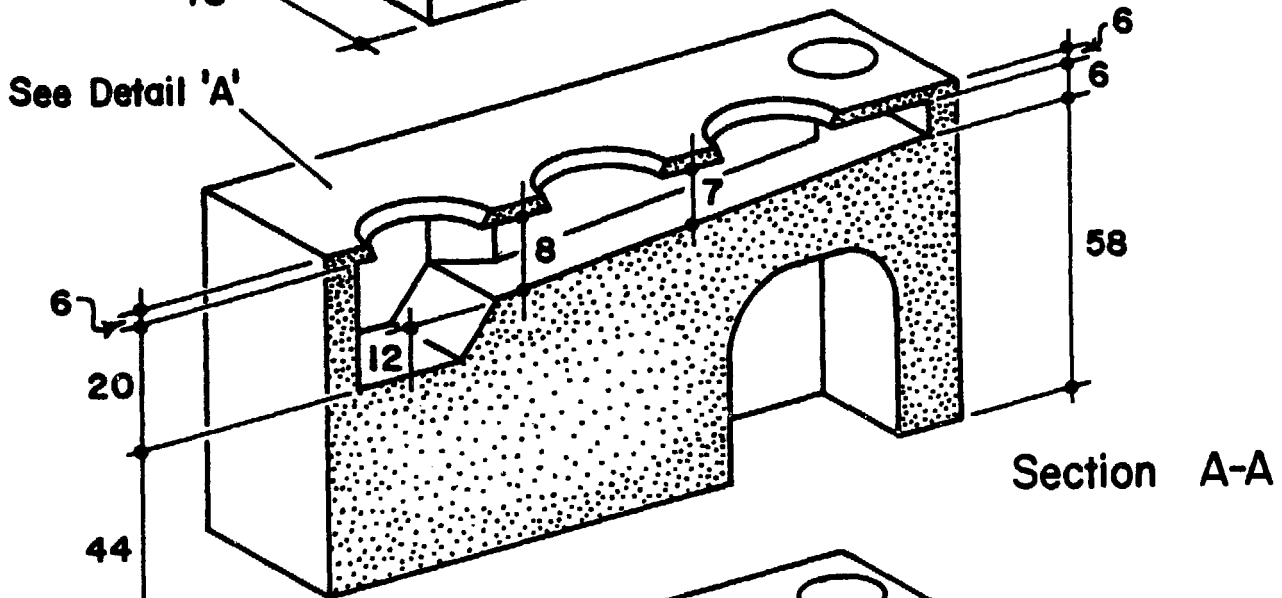
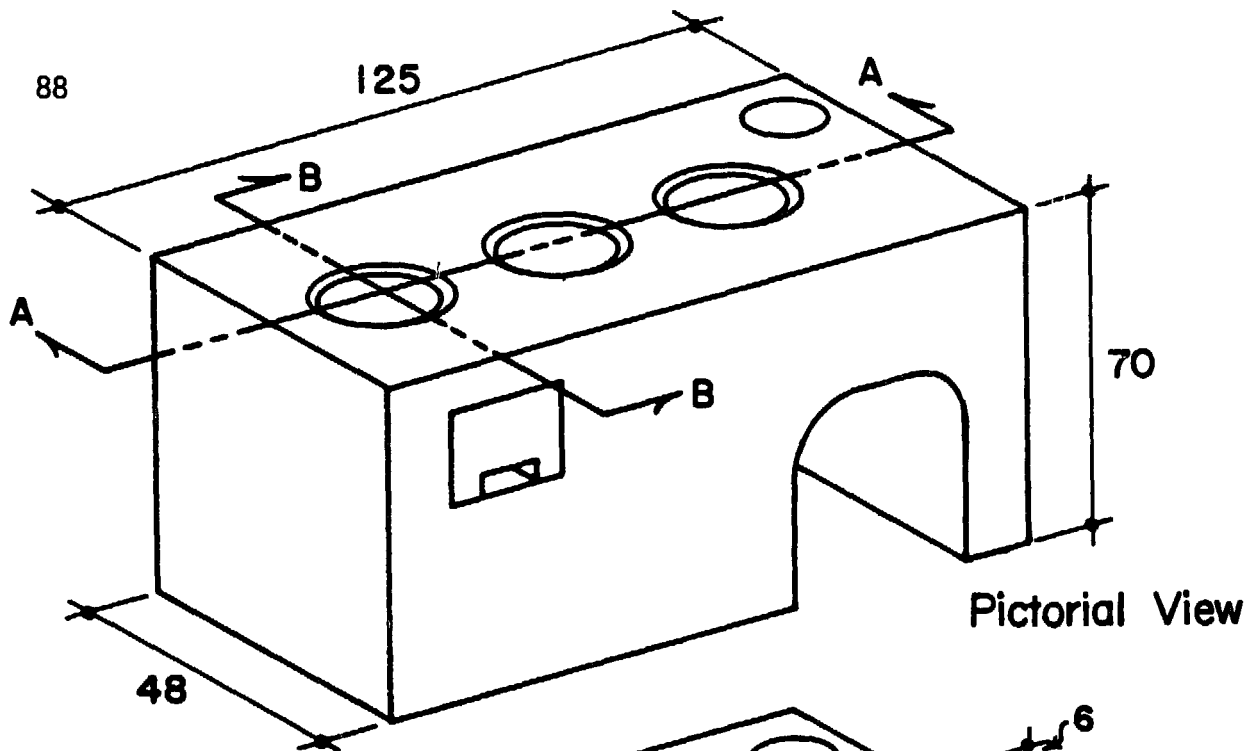

Figure 59

## 2. Make the Stove

Mark the outline of the base of the stove. Use the measurements in Figure 60 as a guide. Begin to lay the bricks, using any good mortar.



All Dimensions in Centimeters

Do Not Scale Drawings

Lay the bricks a layer at a time, overlapping joints where possible. The fuel storage space can be spanned by brick, heavy plank, or sheet metal. The next layer of brick is laid directly over this span.

The dimensions of the firebox and flue have been carefully designed to provide maximum heat and minimum wood consumption. Follow these dimensions carefully when building the stove, cutting or shaping the clay bricks if necessary. (Note: For a small business enterprise, it might be desirable to make the bricks to size instead of cutting them to fit.)

Mortar the cooking plates into place in the same way as for a layer of bricks.

### 3. Make the Chimney

Build the chimney (see Figure 61) of clay tile, brick, or masonry. Masonry is better, safer, and lasts longer than clay tile, but it is more costly.

With masonry, the inside dimensions should be 15cm X 15cm (6" X 6") or 20cm X 20cm (8" X 8") depending on the height of the chimney.

The diameter of the chimney pipe (of hard-baked clay tile) depends on the size of the hearth and the height of the chimney. For chimneys up to 4m (13') high, pipe with a 12cm (5") internal diameter is normally satisfactory. For longer chimneys the pipe diameter can be reduced to 10cm (4"). The minimum recommended chimney height is 2.5m (8') from the cooking surface to the top of the last tile. The top of the chimney should be at least 80cm (32") higher than the highest point of the roof. The chimney must be air-tight. The tiles should be assembled with care, the joints mortared, and a cover provided to prevent rain from entering. The cover should be removable to make cleaning the chimney easier. A tin or zinc finishing plate is provided just below the roof rafters. The space between the metal piece and the roofing must be made watertight by applying a waterproof material such as roofing tar or other available mastic.

# CHIMNEY AND RAIN COVER

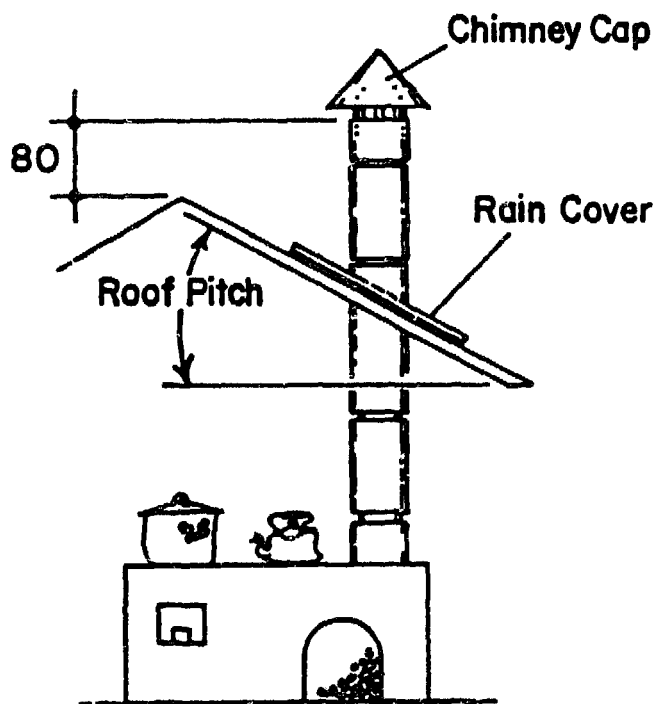
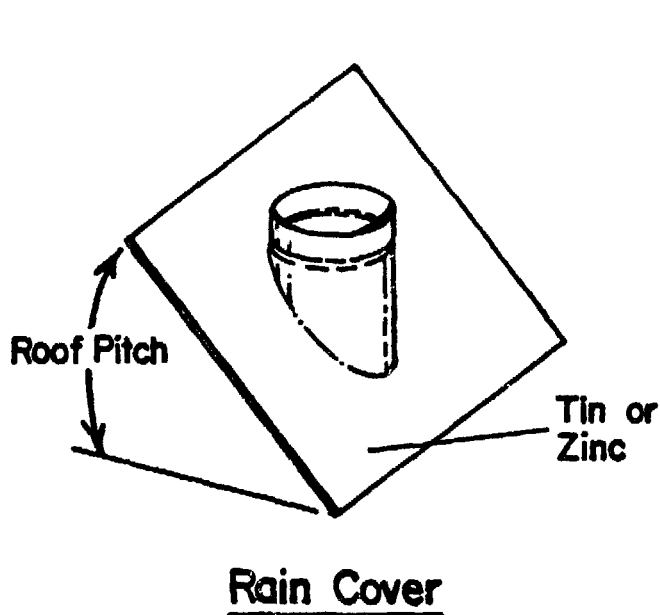

## Cap

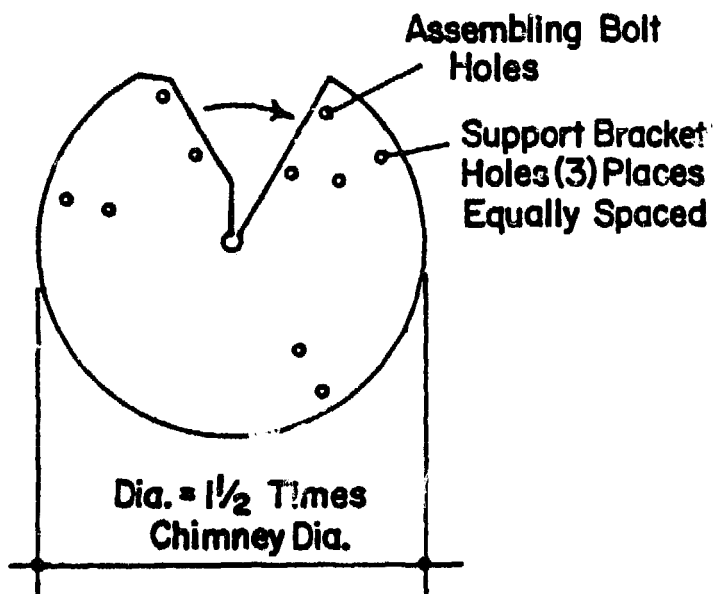
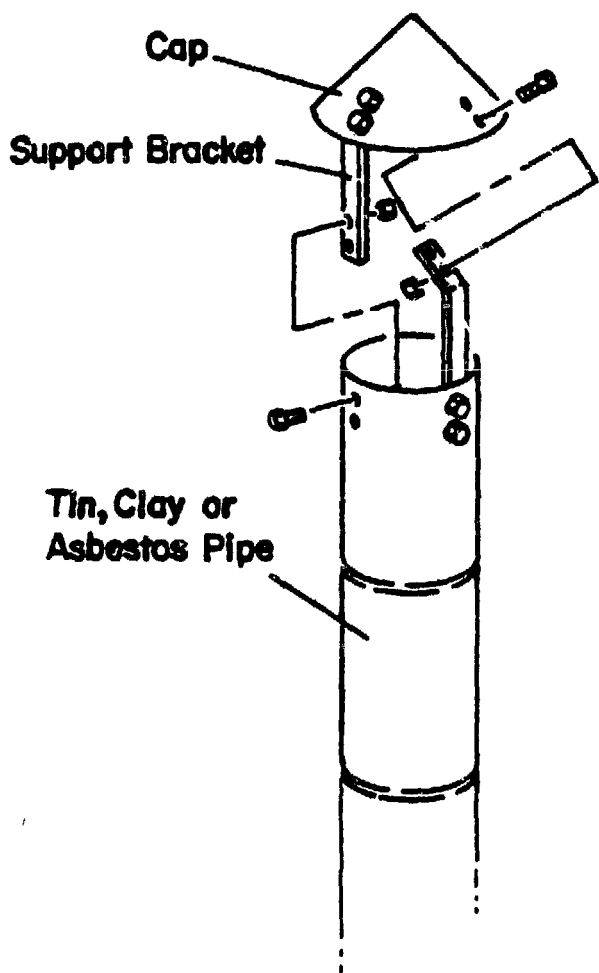

## Support Bracket

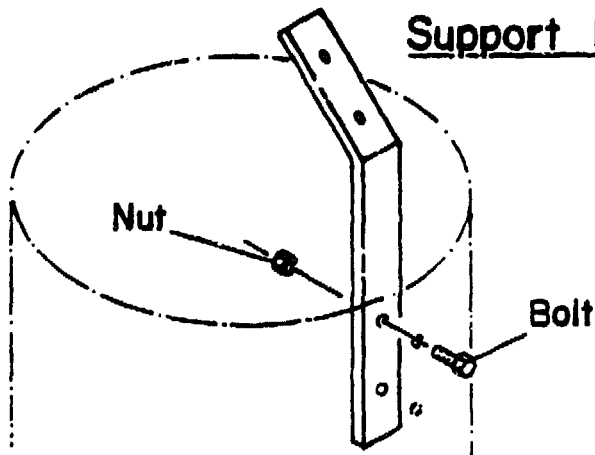

Figure 61



#### 4. Make the Firebox Door

Pour the clay into the special form for the firebox door. While the clay is still damp, finish the door as follows.

Cut a piece of sheet metal into a rectangle approximately 8cm X 10cm (3" X 4"). Smooth the edges. This will be the damper (see Figure 62). Bend the metal on one side as shown to form a hand-grip. The damper will get hot so, if desired, nail thin wooden strips on either side of the 2cm (3/4") fold to protect the fingers.

With a heavy nail, punch a hole in the damper near the top edge. Press the nail into the damp clay so that the damper completely covers the opening in the firebox door. The damper

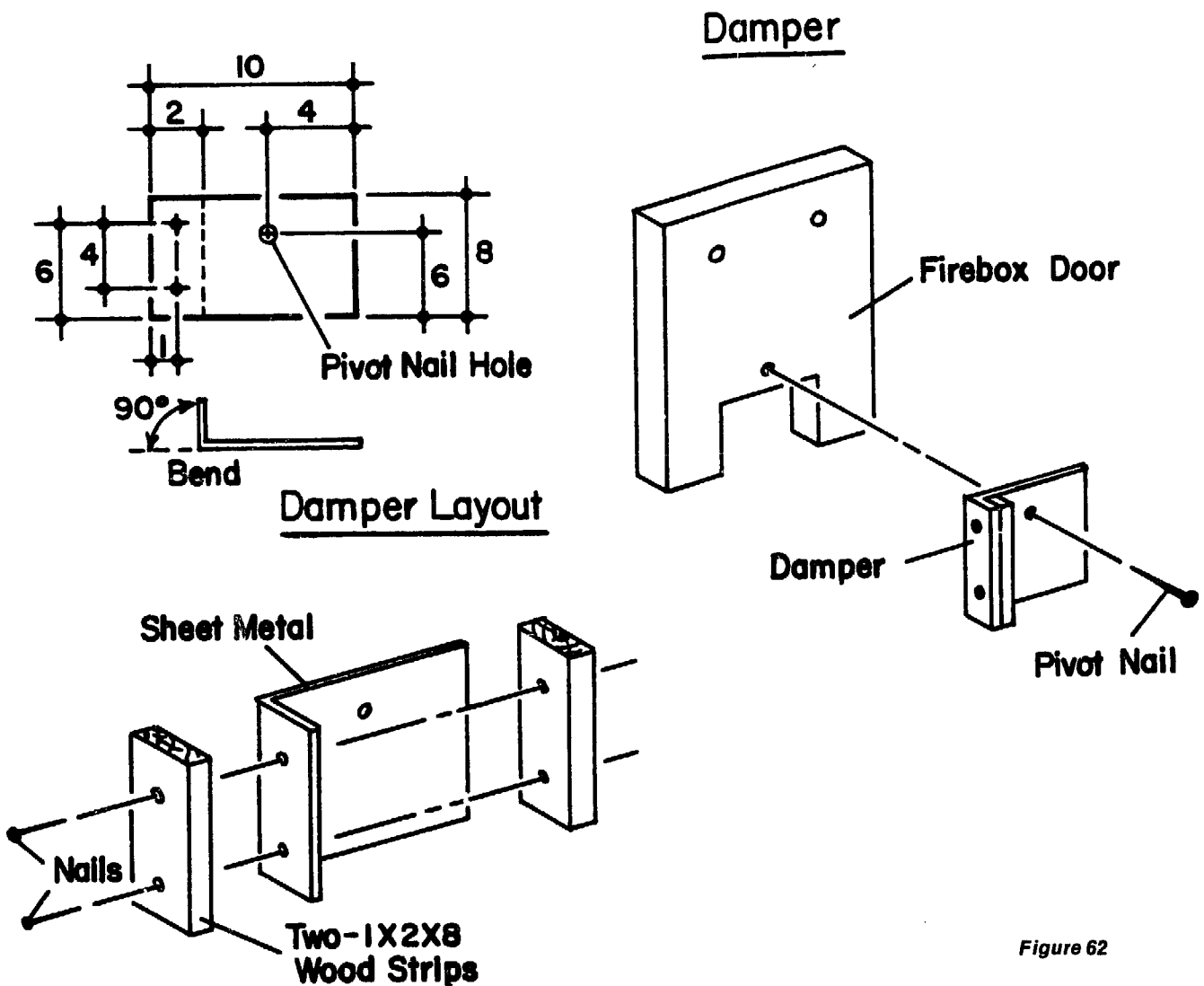

Figure 62

should pivot on the nail, yet fit snugly against the clay block to prevent the passage of air and smoke.

Instead of the metal damper, a snug-fitting block of clay or brick may simply be placed in the opening of the firebox door.

While the clay is still damp cut two holes halfway through the firebox door as shown in Figure 63. These holes will accommodate the handle for the door and should be made to fit it. The handle can be a smooth, forked, hardwood stick, or made of coiled wire. It should be easily removed so that it will not be in the way when the stove is in use. For a permanent handle, make two bolt holes all the way through the door. When the clay has dried hard, attach a wooden or bent metal handle with bolts. (Wood will be easier to handle when hot.) Be sure the handle is placed high enough on the block to clear the damper when it is pivoted into the open position.

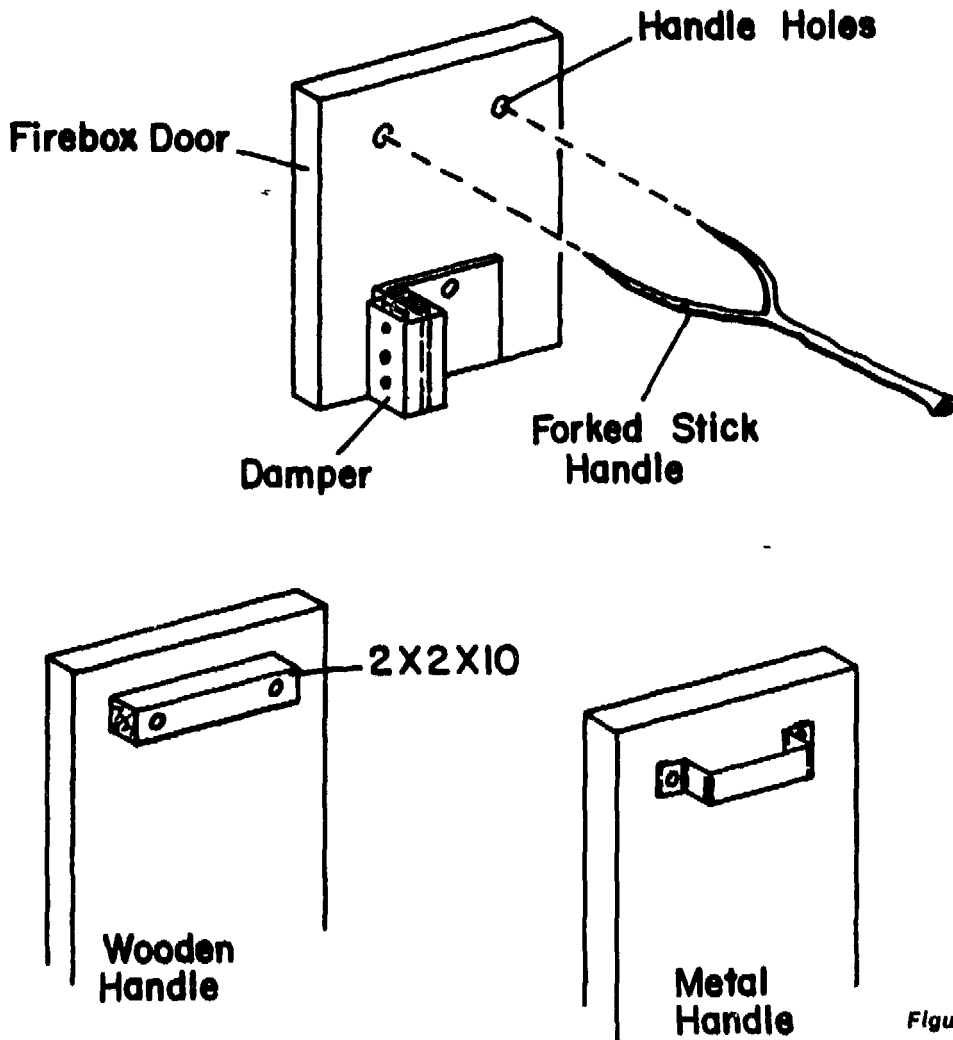

Figure 63

The firebox door must fit snugly into the opening of the firebox. If the block is too large, it may be necessary to sand the edges with rough sand paper. Be careful not to take too much off.

### ***Use of the stove***

To lay the fire, first make a base of wood shavings, other available tinder or crumpled paper, and then add small pieces of wood. Put larger wood, chopped to size, on top. To increase the heat, close the fuel door with the damper open. To lower the heat, half close the damper. To put the fire out, close the damper completely.

Pans should closely fit the cooking holes. The base of the cooking utensil should be 3cm-5cm (1"-2") below the surface of the hole.

An unused hole should always be covered. For pans smaller than the hole, rings/platewashers can be used.

The stove should be cleaned regularly and all damaged places patched immediately. To clean, first cover all pot holes and remove ashes from the firebox.

To clean the chimney, first cover all the pot holes. Remove the chimney cover and sweep the chimney clean, removing all the soot. The chimney should be cleaned at least once every six months.

The use of wet or damp wood causes damage to the chimney through the accumulation of creosote, which leads to risk of fire. Chimneys heavily coated with creosote should therefore be replaced by new ones. If a chimney should catch fire, the passage leading to the chimney should be blocked and the fire extinguished.

## Sawdust cook stove

A sawdust-burning cook stove can be built easily by converting a square 5-gallon (20-liter, roughly) can of the kind used to package paint or vegetable oil. The stove will require a base of brick, stone, or metal, and a fairly heavy metal cover to allow proper draft and to support a cookpot. The chimney can be made of commercially available stovepipe or ducts, or custom fabricated of sheet metal. A 2kg (4-1/2 lb) charge of sawdust will give four to five hours of good cooking fire.

The stove is fueled by packing sawdust into the can around four upright wooden rods (broomsticks are good). The sticks are carefully removed, leaving four holes in the sawdust. A bit of fuel oil is sprinkled on the sawdust around the holes and lighted. When the fire is burning well, the cover is placed on the stove and cooking can begin. Most of the smoke and fumes will be carried away from the cooking area through the chimney.

The stove is not totally smokeless, nor is it 100 percent efficient. The stove's paint can firebox may burn out and have to be replaced regularly. However, the stove does make good use of a fuel source that is frequently overlooked--and often free--and it is smokefree enough to make a significant difference in the cook's environment. If the firebox does have to be replaced, another discarded can is usually available at little or no cost. The chimney and stove top--parts that will probably have to be purchased or specially built--should last indefinitely.

Construction directions given here include the use of commercially available ducting for the chimney. The chimney can be easily made to order in the approximate dimensions of the ready-made parts.

### Materials

- . 1 5-gallon or 20-liter can
- . 1 sheet metal "grill" to cover top of can

- . 4 wooden rods (broomsticks), 5cm (2") diameter, length equal to can depth
- . Base--as desired and as materials are available (stone, brick, or metal)
- . 1 reducer fitting, 10cm X 18cm to 8cm X 16cm (4" X 7" to 3" X 6-1/4")
- . Chimney (ready-made ducting)
- . 1 reducer fitting, 10cm X 18cm to 7cm X 15cm (4" X 7" to 2-3/4" X 6")
- . Duct: 10cm X 18cm X 45cm (4" X 7" X 18")  
           10cm X 18cm X 70cm (4" X 7" X 28")  
           10cm X 18cm X 57cm (4" X 7" X 23-1/2")  
           10cm X 18cm X 107cm (4" X 7" X 42-3/4")  
       (sizes may vary according to installation)
- . Suction exhaust hood
- . Chimney cap
- . Reinforcing rod to support chimney (depends on installation)

### **Tools and equipment**

- . Tin snips
- . Soldering equipment

### **Construction**

#### **1. Make the Stove**

Decide where the stove will be used. It can be used indoors or outside. In some areas cooking is done outdoors in an enclosed patio or courtyard. Be sure to place the stove at least one meter (one yard) away from the walls for safety.

Arrange a flat, level base out of brick, stone, or metal braces. Allow about 15cm (6") clearance between the ground and the bottom of the stove. Set the can on the base, making sure it will not tip or wobble.

See Figure 64 for assembly guidelines.

Cut the top off the can.

Cut or punch four holes in the bottom of the can so that each hole is about one-third of the can's width in from each corner. The wooden rods should fit snugly into these holes.

Cut an 8cm X 16cm (3" X 6-1/4") rectangle out of one side of the can, approximately 3cm (1") from the top.

Fasten the 10cm X 18cm to 8cm X 16cm (4" X 7" to 3" X 6-1/4") reducer around the opening in the can. This can be done by soldering or bolting.

## 2. Make the Chimney

Assemble the rest of the ducting to form the chimney. Sizes given in the parts list are approximate, depending on the installation. They should serve as a guide, however, to the overall height of the chimney, the location of the suction exhaust hood, and the clearance from the surrounding walls. Angles between ducts should be as wide as possible (135° or more) to obtain a better flow of combustion gases. The top of the chimney should be at least 80cm (32") higher than the highest part of the roof.

The suction exhaust hood provides an opening in the chimney which adds enough draft to prevent smoke and gases from backing up into the stove and cooking area. In some places it may be possible to purchase one ready-made, but more likely it will have to be made to order.

Separate two of the vertical sections of chimney duct so that there is a space of about 10cm (4") between them. Bolt or

# SAWDUST COOKSTOVE

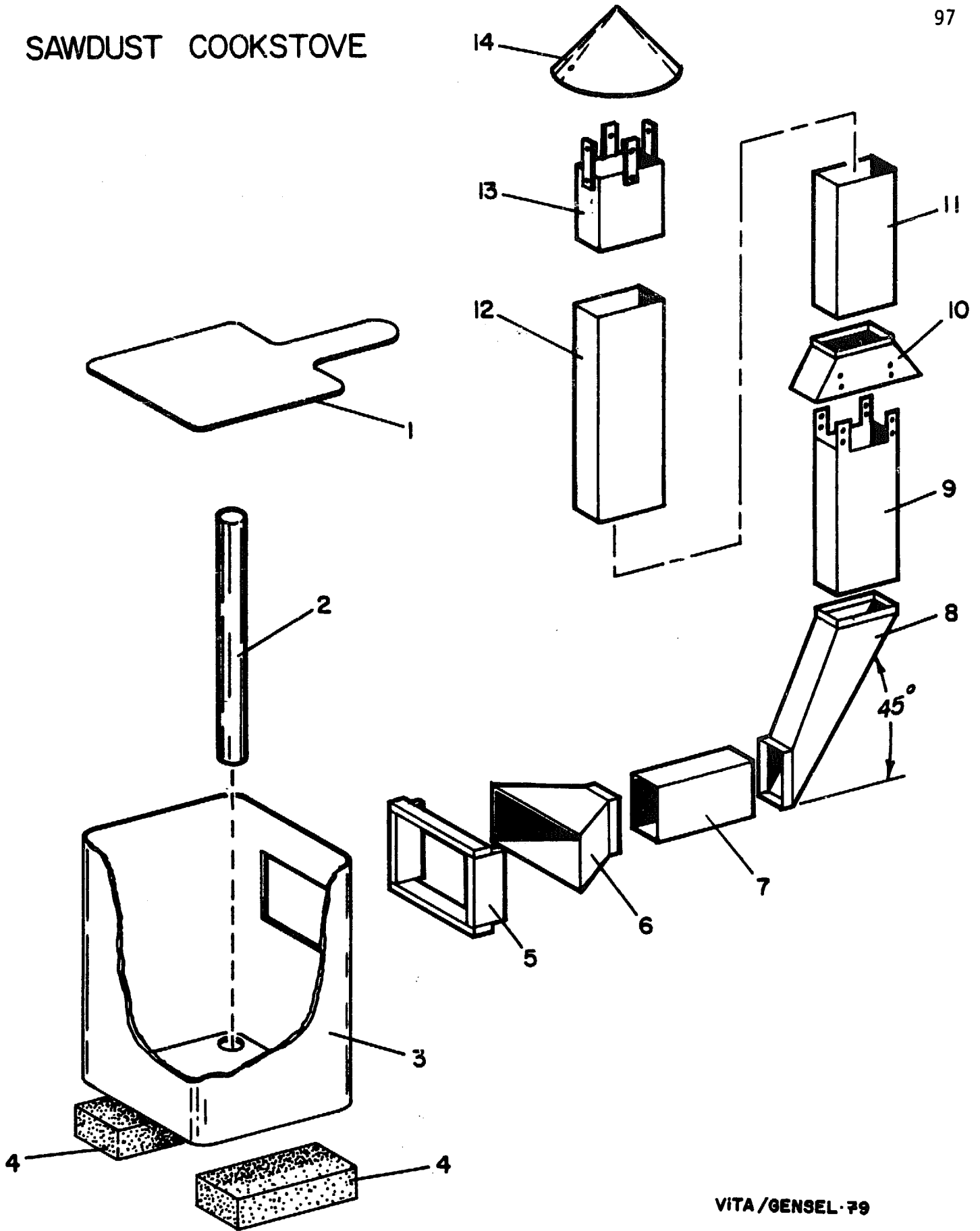

VITA / GENSEL · 79

Figure 64

solder four equally spaced rigid metal strips between the two pieces of duct. To the edge of the upper section attach a flared hood that reaches down far enough to shield the opening, but is wide enough at its lower edge to allow plenty of draft. The flared section can be improvised by using a reducer, or can be cut from the bottom of a chimney cap or a large funnel.

The chimney will require support, depending on how and where the stove is installed. If the stove is used in a courtyard, the chimney can be attached to the wall with guy wires or metal straps. In this case, the chimney should have about a 30cm (12") clearance from the wall to avoid a fire hazard and to provide adequate draft for the suction exhaust hood. Additional support for the semi-horizontal sections may also be necessary.

The end of the duct that fits into the stove requires its own support, wherever the stove is used. This allows the firebox portion to be moved easily for fueling and/or replacement.

### **Use of the stove**

Put a wooden rod firmly into each hole in the bottom of the can. Be sure the rods stand straight.

Add sawdust to a depth of about 16cm (6"). Pack the sawdust with a wooden block and a few sprinkles of water. The sawdust should be packed firmly, but it should not be so wet that it will not burn.

Carefully remove the rods, leaving four holes in the compacted sawdust.

Add a small quantity of fuel oil to each hole and light it with a large wick. It may take some practice to learn the technique of lighting the stove easily.

Once there is a flame in each hole, cover the can to force the smoke and gases out of the chimney.

A 2kg (4-1/2 lb) charge of sawdust will give four or five hours of good cooking fire.



## 5. HOW TO USE STOVES EFFICIENTLY

The choice and use of fuel directly affect the efficiency of a stove. Type and condition of the wood, and the way it is placed in the firebox all contribute to how well the stove will operate.

### Choosing wood

Some fires are more difficult to light and produce less heat than others. The characteristics of the fuel--in this case, wood--and how it is placed in the firebox determine the amount of heat the fire will produce, and the rate at which heat will be given off.

The most important physical characteristic of wood that affects the amount of heat that is released is the amount of moisture and material like resin or sap the wood contains.

Some of the other factors that are important in affecting the heat of the fire are the density of the wood, the size of the wood, how the wood is stacked, the temperature of the area in which the wood is burning, and the amount of air entering the area.

Considerable energy is used to evaporate excess water and other forms of moisture from wood with a high content of moisture. The greater the moisture content of wood, the lower is its heating value, and the harder it is to ignite. Part of the chemical energy of the wood must be used to boil off the water. As the water is released, it dilutes the volatile gases and lowers the temperature of the gas mixture, making ignition more difficult (see Figure 65).

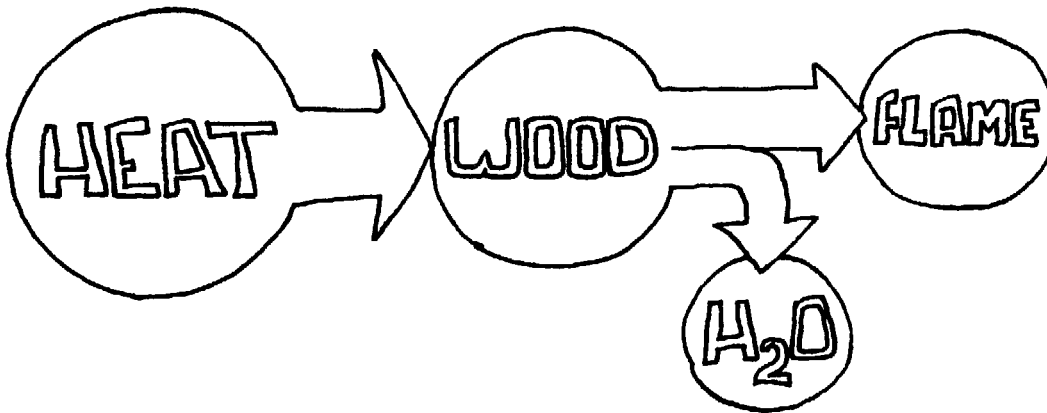

Figure 65

The denser the wood, the harder it is to ignite and the longer it takes to burn. Dense wood also produces relatively more

coals. In the case of less dense wood, more of the charcoal is burned while the gases are still burning. Thus softwood and coconut husks produce less charcoal and more tars, and evolve more gases at a lower temperature than hardwoods. However, since dense wood produces more heat per unit volume, smaller fireboxes are needed to produce the same heat output (Figure 66).

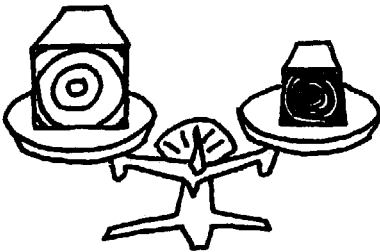

Figure 66

Pieces of wood under 1-1/4cm to 2-1/2cm (1/2" to 1") diameter will usually sustain their own flame, whereas larger pieces of wood will not, unless there is an external source of heat such as charcoal or kindling (see Figure 67). Large pieces of wood may continue to burn without flames, if sufficient air is available and if the wood is not too damp. These smoldering

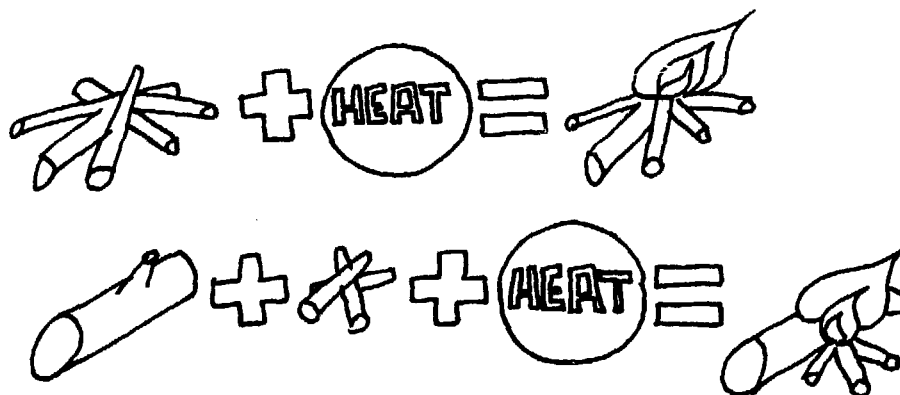

Figure 67

logs give out considerable heat and are often used to keep a 'pot on the boil.'<sup>1</sup>

In choosing wood which will burn efficiently, the type of wood is important. Some wood burns quickly, giving out a lot of heat over a short period of time. Other wood is slow burning, giving out more even heat for a longer time. Different kinds of wood may therefore be appropriate for cooking different kinds of food.

Different varieties of wood are capable of producing different amounts of heat per unit volume. This is due to such factors as the moisture content and the density of the particular type of

---

<sup>1</sup>An ingenious and efficient method of providing energy both for heating and cooking is the fire stick used by the Australian Aborigines. The fire stick is a piece of hardwood 5-10cm (2-4") in diameter that has been ignited at one end. Once ignited, it is pulled away from the center of the fire and left to smolder slowly in the sand. When camp is moved, the person holds the fire stick in front of his body during the journey. The smoldering stick gives out sufficient heat to protect the person from the freezing desert nights but does not go into flames for two reasons:

1. the wood gases are blown away from the hot surface before they can ignite, and
2. since the stick has a diameter greater than 2-1/2cm (1"), the glowing end is not able to sustain its own flame.

On arrival at a new camp the smoldering end of the stick is held against some dry grass or leaves and a new fire is started.

wood. However, many users of wood stoves have little choice about which type of wood to use. This table shows the heating value of some different varieties of wood. It assumes that all the wood is thoroughly dried.

Type of Wood Tropical Species	Basic Heat Value (dry) BTUs/lb
Ash (white) .....	8900
Beech .....	8760
Birch (white) .....	8660
Cedar (white) .....	8400
Cypress .....	9850
Elm .....	8810
Fir (Douglas) .....	9000
Hemlock .....	9700
Hickory (Shelback) .....	8680
Maple .....	9140
Oak (black) .....	8180
Oak (red) .....	8670
Oak (white) .....	8820
Pine (pitch) .....	1135
Pine (white) .....	8880
Pine (yellow) .....	9600
Poplar .....	8920
Spruce .....	8700
Tamarack .....	8780

## Using wood

A stove is being operated inefficiently when too much or too large a piece of wood is used for a short cooking time, or when the air inlet damper is set too low for good combustion efficiency.

Efficient use of the stove begins with the placement of wood in the fire. Crooked pieces of wood stacked unevenly channel air between the pieces and allow the air to mix with the volatile wood gases. If you blow at the base of a smoldering fire that has been well stacked, the wood will ignite. However, if you blow at a point where air cannot circulate, the fire will not ignite and your blowing on it may put it out. In this case, the air has blown the flammable gases away from a hot area too cool for them to ignite. It is essential that air enters the fuel in the fireplace or stove so that it can circulate and mix well with the gases produced in the burning process (see Figure 68).

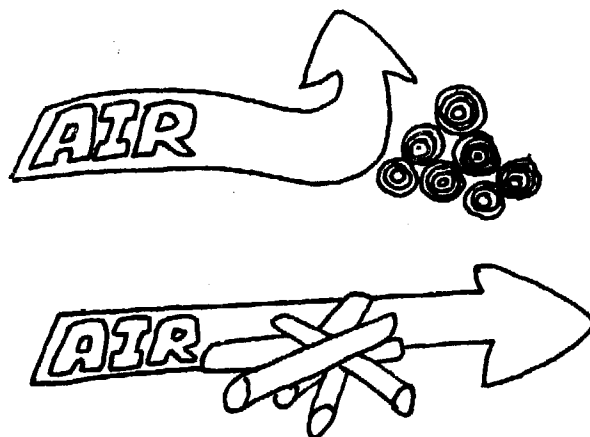

Figure 68

To obtain efficient combustion of wood, the area around the wood's surface should be at a temperature above that of the ignition point of the volatile gases, and should have enough air to cause the gases to ignite.

# Dictionary of terms

**BAFFLE**--Used to redistribute heat, to redirect the flow of exhaust gases so they can be better used. In stoves discussed in this book, baffles are usually a mound or step in the tunnel.

**BINDERS**--Materials that hold things together, such as glue or cement.

**BRITISH THERMAL UNITS (BTUs)**--One type of heat value measure, a BTU is the quantity of heat required to raise the temperature of one pound of water by one degree Fahrenheit.

**COMBUSTION**--Burning, the burning process.

**COMPACTED**--Packed until solid.

**CONDENSATION**--The liquid that forms when a gas cools.

**CONDUCTION**--The transfer of heat through the air between the fire and the pot. In a traditional open fire, heat is lost into the open air; in the improved stove, passages or ducts leading from the fire to the cooking pots are sealed so that only air controlled by the dampers reaches inside the stove.

**CONSERVE**--To keep from loss or waste; to save.

**CONVECTION**--The transfer of heat by circulatory motion: hot gases rise and cooler gases sink, creating a turbulence. In a traditional, open wood fire, convection is uncontrolled and the wind can disperse the hot gases and prevent them from reaching the pot. In an improved stove, passages for the flow of air and gases are constructed in such a way (for example, by adding baffles) that convection is

increased. The turbulence ensures that the hot air is bounced directly up against the bottom of the pot, rather than being carried openly across the bottom of the pot.

CREOSOTE--A burnable liquid or tar-like substance that sometimes forms in chimneys. It forms when unburned firebox gases cool. It can cause dangerous chimney fires.

DAMPER--A sliding door that controls the gas and air flow in a stove.

DOWN-DRAFT--Air that flows down the chimney and into the room.

DRAFT--An air current in a stove.

EFFICIENCY--In stoves, this is a measure of how well fuel is used, or the economy of fuel use. Efficiency is a measure of the amount of heat actually used, as compared to the amount of heat which was available. The better the efficiency of the stove, the more of the available heat is actually used for cooking. To a user, the only meaningful measure of a stove's efficiency is whether it burns less wood and gives at least as much satisfaction as the previous method.

FIREBOX--The chamber in which fuel is burned.

FLUE--A duct or passage for gas or air.

GRATE--A frame for holding burning fuel.

INLET--Opening that allows air or gas to enter.

KINDLING--Small pieces of wood, dry leaves, etc. Used to start fire.

LORENA--A sand and clay mixture. (From the Spanish words lodo [mud] and arena [sand]).

MACHETE--A large knife from South America.

MASONRY--Something made from stone, brick, or hard material.

MOISTURE CONTENT--The moisture content of fuel is the amount of water contained in a given unit of that fuel. Recently cut wood can obtain significant amounts of water; this moisture lowers heat value (in other words, the number of BTUs available) obtained from a fire in two ways. First, the water represents a good portion of the weight in the total mass of wood but does not add to the heat value of the fire. Second, what heat is available when the wood is burned must be used first to dry the wood.

NATURAL DRAFT--A flow of air that is not man-made.

OUTLET--An opening that permits air or gas to exit.

PERFORATED--Full of holes.

POT HOLES--The holes on the top of a stove where pots are placed.

RADIATE--To give off heat.

RADIATION--Heat from a hot object that can be felt at a distance.

RAKE--To stir or move around.

SILT--Sediment deposited by water; fine sand.

SMOLDER--To burn or smoke without flame.

STOKING--Adding more fuel.

SUBSOIL--The bed of earth or earthy material under the surface soil. It usually has little organic matter.

SUCTION--Pulling air through.

THERMOCOUPLE--Metal device used to measure temperature accurately.



TOE SPACE--Space at the bottom of a stove for a person's feet.

TOXIC--Poisonous.

TROWEL--A hand tool used for spreading and smoothing.

WARMER BASIN--A hole cut into the top of the stove in which food can be warmed but not cooked. There is no direct contact with hot gases from the firebox.

WATERPROOF--Not letting water through.

# Bibliography

- Ahula, B.D., Gupta, O.N., and Srinivasan, K.S., A Study on the Efficiency of Chulas, Technical and Research Report #17, National Buildings Organization and UN Regional Housing Center/ECAFE. (UDC 643.332) (New Delhi: n.d.).
- Azbe, Victor J., Theory and Practice of Lime Manufacture, A Collection of Articles 1923-1926, June 1946.
- de Lepelriere, Guido and Ki-Zerbo, Jacquelin, Improvement of Fireplaces for Domestic Use of Firewood: Its Potential and Impact on the Sahel, report to the Club du Sahel through a joint consultancy for CILLS and the UNFAO, May 1979.
- Earl, D., Forest Energy and Economic Development, Clarendon Press, Oxford, Massachusetts USA, 1975.
- Evans, Ianto, edited by Kalin, Jim and Darrow, Ken, Lorena Owner-Built Stoves, Appropriate Technology Project/Volunteers in Asia, (Stanford, California USA, 1979).
- Frieire, P., Education: The Practice of Freedom, London and Readers Publishing Co-operative, 1974.
- Goldemberg, J. and Brown, R.I., Cooking Stoves: State of the Art, Institute of Physics, University of Sao Paulo, Brazil (n.d.).
- Harahap, Dr., a comprehensive survey on step grate cookers, forthcoming; Development Technology Center, Bandung, Indonesia.
- Harris, M., "The Cultural Ecology of India's Sacred Cattle," Current Anthropology #7, 1966.
- Hiskinger, personal correspondence, 1979.

- Karki, A. and Coburn, B. The Prospect of Biogas as One of the Sources of Energy in Nepal, 10th World Energy Conference, Istanbul, Turkey, 1977.
- Lamb, Bruce, personal correspondence to ITDG, 1979.
- Lee, C.K., Chaiken, R.E. and Singer, J.M., Charring Pyrolysis of Wood in Fires by Laser Stimulation, 16th Symposium on Combustion, 1976.
- Makhijani, A. and Poole, A., Energy and Agriculture in the Third World, Ballinger Publishing Co., Cambridge, Massachusetts USA, 1975.
- Martin, L.H., The Economy and Economics of Cooking Fuels in Ghana, Washington University, Washington USA.
- Mukhopadhuau, T.K. and Maheshhwari, R.C., Husk Fired Domestic Stoves for Rural Communities, 16th Annual Conference, ISAE, Kharagpur.
- Nuruzzman, Bangladesh Council of Scientific and Industrial Research, personal correspondence, 1979.
- Odend'hall, S., "Energetics of Indian Cattle in Their Environment," Human Ecology #1.
- Openshaw, K., The Gambia: A Wood Consumption Survey and Timber Trend Study 1973-2000, unpublished report to the ODA/LRD Gambia Land Resource Development Project, Midlothian, Great Britain, 1973.
- \_\_\_\_\_. "Wood Fuels in the Developing World," New Scientist, 61:883, 1974.
- \_\_\_\_\_. Results of test on the Thai Stove, personal correspondence, 1979.
- Overhaarte, J.C., Family Cooker, Technische Hogeschool, Eindhoven, The Netherlands, 1977.

- Raju, S.P., Smokeless Kitchens for the Millions, Christian Literature Society, Madras, India, 1961.
- Reddy, A., "Simple Energy Technologies for the Rural Family," Village Technology in Eastern Africa, UNICEF, Nairobi, Kenya, 1976.
- Richards, A.I., Land, Labour and Diet in Northern Rhodesia--An Economic Study of the Bamba Tribe, Oxford University Press (first published 1939), 1960.
- \_\_\_\_\_, Hunger and Work in a Savage Tribe, Routledge and Kegan, Paul, London, England, 1932.
- Richolson, Jerry, Department of Forestry, Fiji, personal correspondence, 1979.
- Shaller, Dale V., A Sociocultural Assessment of the Lorena Stove and Its Diffusion in Highland Guatemala, March 1979.
- Singer, H., Report to the Government of Indonesia on Improvement of Fuelwood Cooking Stoves and Economy in Fuelwood, Food and Agriculture Organization, Rome, Italy, 1961.
- Siwatibau, S.A., A Survey of Domestic Rural Energy Use and Potential in Fiji, Center for Applied Studies, Fiji, 1978.
- Thomas, B., Two Studies in African Nutrition: An Urban and Rural Community in Northern Rhodesia, Rhodes-Livingstone Papers #24, International African Institute, 1954.
- Walton, J.D., Roy, A.H. and Bomar, S.H., A State of the Art Survey of Solar Powered Irrigation Pumps, Solar Cookers and Wood Burning Stoves for Use in Sub-Sahara Africa: Final Technical Report, Georgia Institute of Technology, Atlanta, Georgia USA, January 1978.
- Wike, Ole, Wood Stoves: How to Make Them, Northwest Pubs, Anchorage, Alaska USA, 1977.

## USER'S QUESTIONNAIRE

This manual was published to help those worldwide who want to use improved stoves to save fuel. VITA needs your help to keep this technical information up to date. We want to know how the ideas in this book worked for you. Please--will you take a minute to answer the questions below?

Please send your answers to:

Woodstoves  
Volunteers in Technical Assistance  
3706 Rhode Island Avenue  
Mt. Rainier, Maryland 20822 USA

Name \_\_\_\_\_ Title \_\_\_\_\_

Organization \_\_\_\_\_

Address \_\_\_\_\_

\_\_\_\_\_

Write your answers under each question. Tear out and mail the whole page.

1. Was the information in this book easy to understand?

2. Was the information complete?

3. Did you use the book as part of a training program? How might it be improved for teaching about stoves?
  
4. Have you built any of the stoves presented in this book? If so, which stoves did you build?
  
5. What did your neighbors and people in the area think of the new stove? Were you able to encourage others to try it? Why?
  
6. What specific changes do you suggest for the stove designs? How can this book itself be improved?
  
7. In the space below, please give details about your stove:
  - a) construction details
  - b) changes from the designs in this book
  - c) changes for your location
  - d) test results
  - e) other details

(Use extra pages if necessary.)

THANK YOU FOR YOUR HELP!