

AT MICROFICHE REFERENCE LIBRARY

A project of Volunteers in Asia

Brief Notes on the Design and Construction of
Woodburning Cookstoves, with Particular Reference
to the CETA System

by: Roberto Lou Ma

Published by:

Centro de Experimentacion en Tecnologia
Apropiada
15 Avenida 14-61, Zona 10
Guatemala City
Guatemala

Paper copies are \$ 2.00.

Available from:

Centro de Experimentacion en Tecnologia
Apropiada
15 Avenida 14-61, Zona 10
Guatemala City
Guatemala

Reproduced by permission of the Centro de
Experimentacion en Tecnologia Apropiada.

Reproduction of this microfiche document in any
form is subject to the same restrictions as those
of the original document.

roberto lou ma

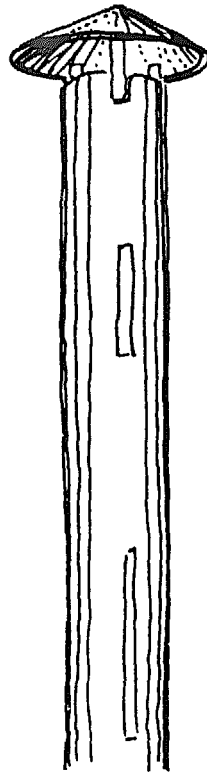

brief notes on the design and construction of woodburning cookstoves, with particular reference to the ceta system

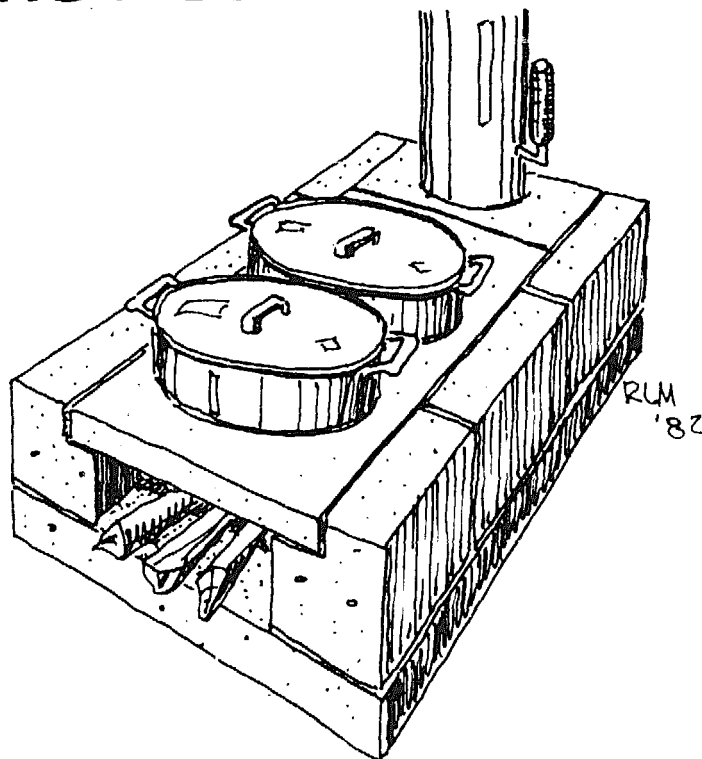

CETA
june 1982

roberto lou ma

**brief notes on the design and
construction of woodburning
cookstoves, with particular
reference to the ceta system**

U.S. \$ 2.00

Centro de Experimentación en Tecnología Apropriada
15 Ave. 14-61 Zona 10
Guatemala, Central America

CETA
june 1982

BRIEF NOTES ON THE DESIGN AND CONSTRUCTION OF WOODBURNING COOKSTOVES,
WITH PARTICULAR REFERENCE TO THE CETA SYSTEM

By Roberto Lou Ma
June, 1962

I. GENERAL STOVE DESIGN CONSIDERATIONS

Black beans and tortillas constitute the basis of the Guatemalan diet. Rural people customarily do their cooking in pots and hotplates resting on stones over an open woodfire. This method is not only wasteful in fuelwood but the smoke indoors is a nuisance and a threat to health.

By enclosing the fire in a stove, thermal losses to the environment are reduced and a greater proportion of the combustion heat is able to reach the cooking vessels, thus lowering wood consumption. Smoke is also diverted off the kitchen through the chimney.

Many types and designs of fuel saving cookstoves have been proposed for use by the poor of the third world, and are being promoted with varying degrees of success in several countries.

Some stove types are built monolithically from a single material, for example earth. Others are assembled by parts, combining various materials and often involving some prefabrication.

Most woodburning cookstoves can be regarded at, in ultimate analysis, as simple tunnel structures, with holes on top to accomodate the cooking pots. Firewood is fed at the frontal opening. Flame, hot gases and smoke flow through the tunnel and under the pots, to be eventually evacuated up the chimney installed at the end.

CETA has been active in cookstove research and development since 1979. As a result of experimental work done, a number of practical and techinal features, considered to be essential for simple and fuel efficient stove design have been

identified (References 1 & 2). The following guidelines are based on these findings:

- 1)- General. Design, regarding concept, geometry and use of materials, shall be kept as simple and direct as possible.
- 2)- Pots and Potholes. The stove shall have two or at the most three closely spaced potholes, in sizes appropriate to the intended cooking. All pots shall have lids. Metal pots are to be preferred to earthenware, because of higher thermal conductivity. Maximum exposure of pot surface to combustion heat and minimum exposure to the environment shall be propitiated by sinking the pots deeply into the potholes whenever possible.
- 3)- Firebox. Firebox dimensions shall be the minimum compatible with the size of fire required by the proposed culinary tasks. For ordinary domestic cooking, and taking into consideration the sizes of firewood commonly used, a height of 12 to 15 cm (from floor to bottom of pot); a width of 60 to 90 percent the diameter of the first pothole; and a length of 30 to 45 cm, have been found to be adequate.
- 4)- Dampers and Baffles. Means shall be provided to control draft, and thus govern the rate of combustion as required. In this respect, a damper placed at the entrance or at the exit of the stove duct is all that is needed. Chimney mounted butterfly dampers prove to be very convenient, as they are simple to install and operate.

Means shall also be provided to direct the maximum possible of the generated heat to the pots. For this purpose, a simple baffle block, placed after the firebox as to step up the duct floor to within 2 to 3 cm of the bottom of the second (and third) pot, will generally suffice.
- 5)- Use of Materials. For construction, maximum choice of thermal insulating materials shall be made. If for some reason a metal deck is indicated, its surface area shall be kept as small as possible, in order to minimize radiations losses.

CETA has experimented with many kinds of stoves and has found that, regardless of stove type or concept, high efficiency can generally be achieved if the above re-

quirements are met in the design.

Some design refinements to further improve completeness of fuel combustion and general performance are presently under study (use of grates, firebox doors, etc.).

In addition to being fuel efficient, a cookstove shall be of simple construction, operation and maintenance; durable, esthetically appealing, cost attractive, and susceptible of being mass produced with simple local technologies, skills and resources.

II. THE CETA SYSTEM OF STOVE CONSTRUCTION

What began as a quick and simple means for assembling experimental woodburning cookstoves for testing (References 1, 2 & 3), has been developed into a system for building cookstoves from mass produced prefabricated elements.

According to this system, the stove body is conformed by the BASE (A), the SIDES (B) and the DECK (C) (see drawings). Each of these main components can be manufactured onepiece or in sections, and, in assembling the stove, all elements are laid together dry, that is, without any binding mortar. Other essential parts of the stove are the CHIMNEY (E), BAFFLE (F) and DAMPER (G).

For the sides, blocks are preferred, as they are simpler to produce and easier to handle than large pieces. Because the joints between deck and sides are rabbeted, the stove is airtight enough for adequate functioning, and also holds well its shape under use.

The system offers great flexibility in regard with geometric aspects, such as size and shape of the firebox; number, size and distribution of potholes; size and shape of hotplate; number, type and position of baffles and dampers; etc., as to satisfy the varying needs and conditions of any specific application. And also allows for a great variety of materials in the prefabrication of the stove components:

- 1)- For the base, reinforced concrete has been more commonly used. The base can be omitted though, and the sides laid directly on the kitchen

floor or on a masonry, adobe or earth working platform.

- 2)- Blocks for the sides can be produced from earth, ceramic, soil-cement, concrete, pozzolans, etc. For example, CETA has employed a hand operated block press to produce up to 60 soil-cement side blocks per hour, enough for ten stoves.
- 3)- Decks can be manufactured from sheet iron, iron plate, ceramic, reinforced concrete, soil-cement, cast iron, etc. Some decks provide large flat surfaces usable as hotplates, an indispensable element in the Guatemalan kitchen. The position of the deck sections are interchangeable as required by use. One stove version uses rectangular pots and hotplate as deck, which offers maximum heat collecting pot surface area (see drawings).

Other advantages of using small prefabricated elements for stove construction in accord with the proposed method are:

- 1)- The elements can be mass produced from local materials and by artisan means, in small village plants, at low cost.
- 2)- With centralized or semicentralized production, good control can be exercised, and high quality in materials and workmanship obtained.
- 3)- Being light and compact, the elements are easy to handle and store.
- 4)- They are simple to use. A stove can easily be assembled by the proposed user, with little or no assistance, in about 10 minutes.
- 5)- Because there is no need to bind them with mortar, these components are easy to remove and replace when necessary.
- 6)- Their small size makes them less vulnerable to fracture from heat expansion.
- 7)- With a small investment, an adequate stock of spares can be maintained locally.
- 8)- As parts are standardized, each unit built is an exact replica of an original and well proven design.

- 9)- Prefabrication and mass production facilitates the implementation of large scale testing, promotion and dissemination programs.

Optatively, but not necessarily, the stove components can be assembled together binding them with mortar or mud.

Stoves built by the CETA system have a neat and handsome appearance. In comparative tests with traditional cooking methods, fuel economies in the order of 50 to 67 percent have been attained in performing ordinary Guatemalan cooking tasks, with stove models that fulfill the design requirements above mentioned.

At the present, CETA is engaged in the development of simple facilities (tooling, shop procedures, materials, etc.) to mass produce stove parts in small village plants.

III. REFERENCES

- 1)- Roberto Lou Ma, August 1979, *ENSAYOS DE EFICIENCIA EN COCINAS DE LEÑA*, Informe general a William G. Mathews Associates Limited, unedited.
- 2)- Roberto Lou Ma, January 1981, *EVALUACION DE LA EFICIENCIA Y UTILIDAD DE PEQUEÑAS COCINAS A LEÑA PARA EL AREA RURAL*, Centro de Experimentación en Teconología Apropiada y Centro de Investigaciones de Ingeniería USAC, Guatemala.
- 3)- David Cappaert, August 1981, *STOVE TESTING IN GUATEMALA*, Cookstove News, Vol. 1, No. 2, August 1981, The Aprovecho Institute.

REFERENCES TO DRAWINGSSTOVE COMPONENTS

- (A) BASE
- (B) SIDES
- (C) DECK
- (D) CHIMNEY PLATE
- (E) CHIMNEY
- (F) BAFFLE
- (G) DAMPER

DECK OPTIONS

- (1) Sheet iron, 1/8" thick
- (2) Plate iron, at least 1/4" thick
- (3) Ceramic
- (4) Reinforced concrete
- (5) Strap iron frame and hoops, filled with concrete, soil-cement or sand clay
- (6) Cast iron
- (7) Rectangular pots and hotplate. Possible combinations:
 - a)- Two pots and small hotplate
 - b)- One pot and large hotplate

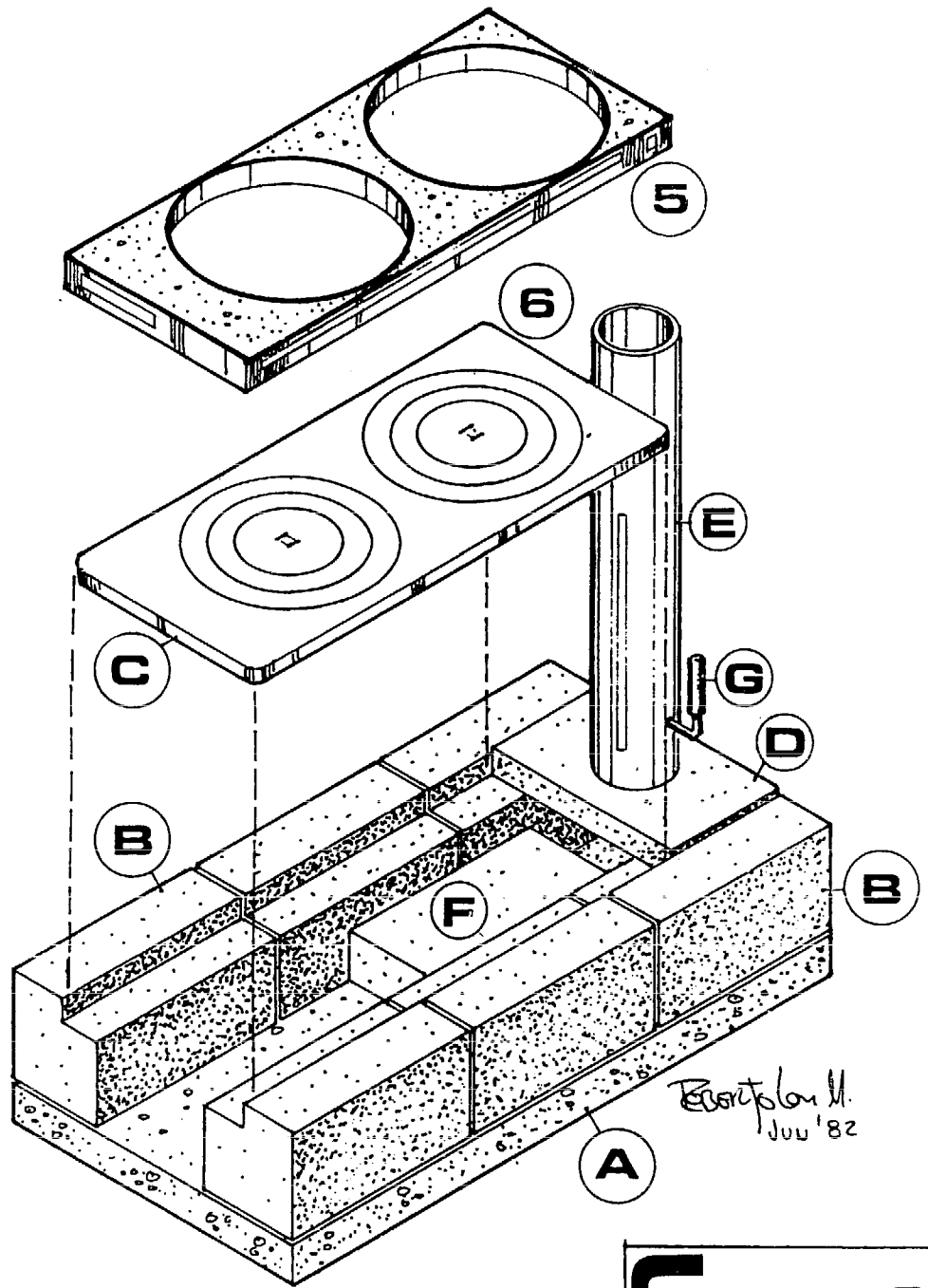
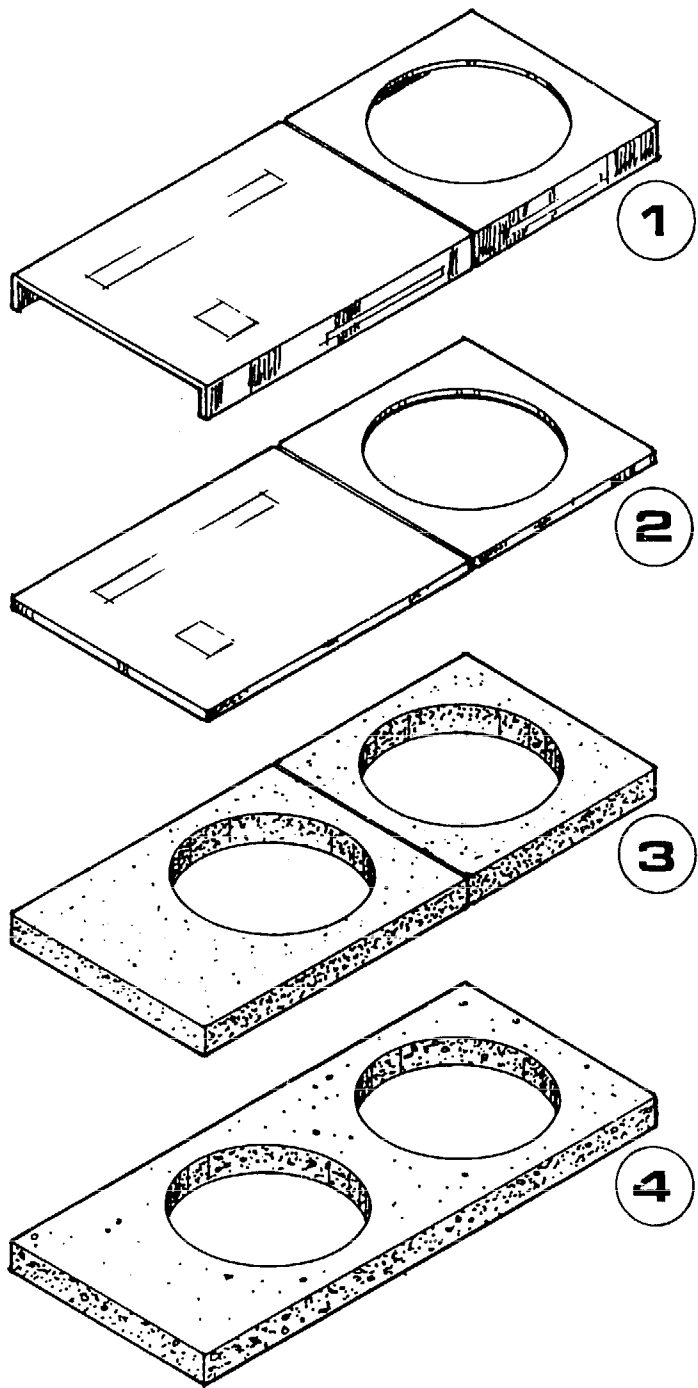

*Basilio M.
JUN '82*

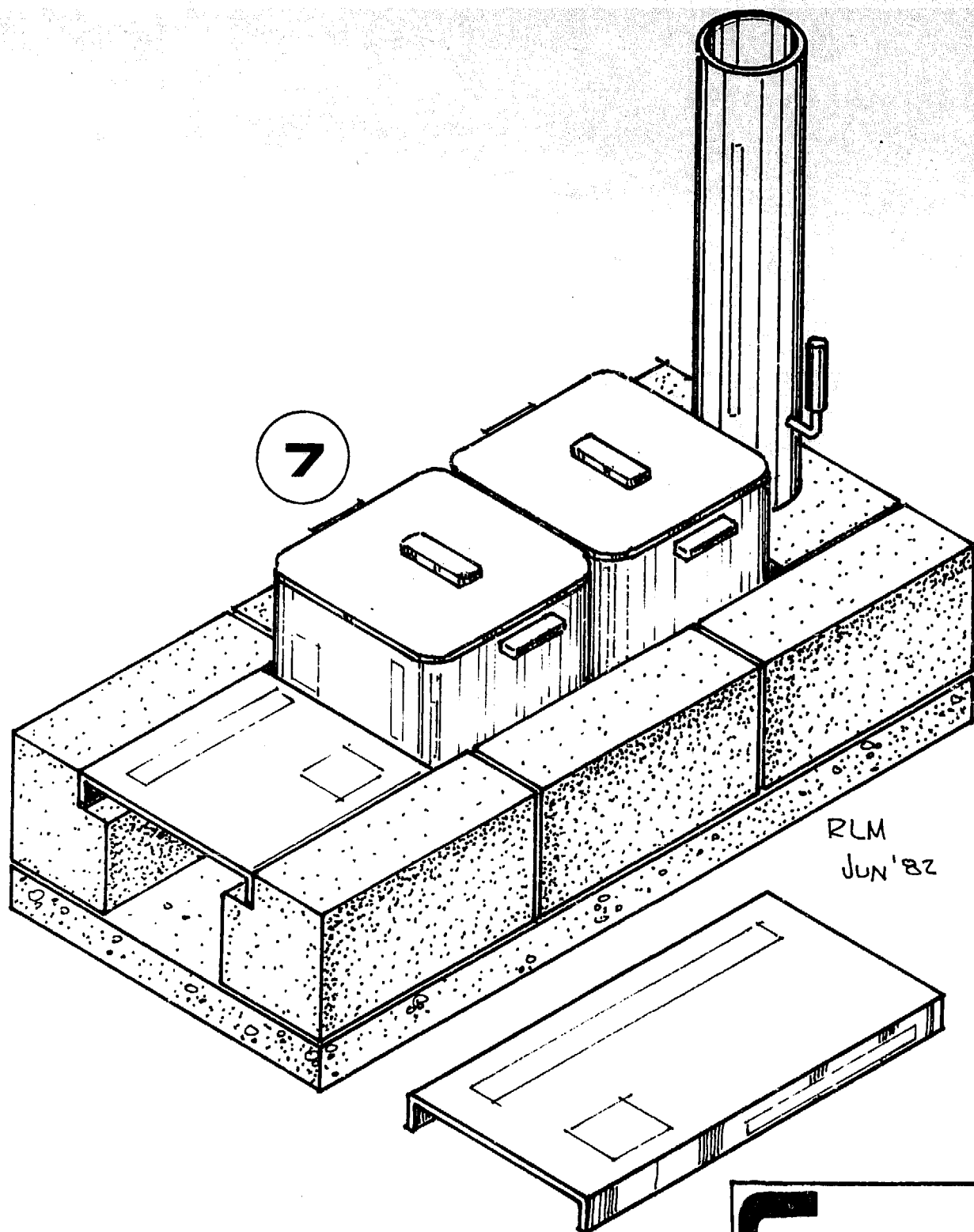

10

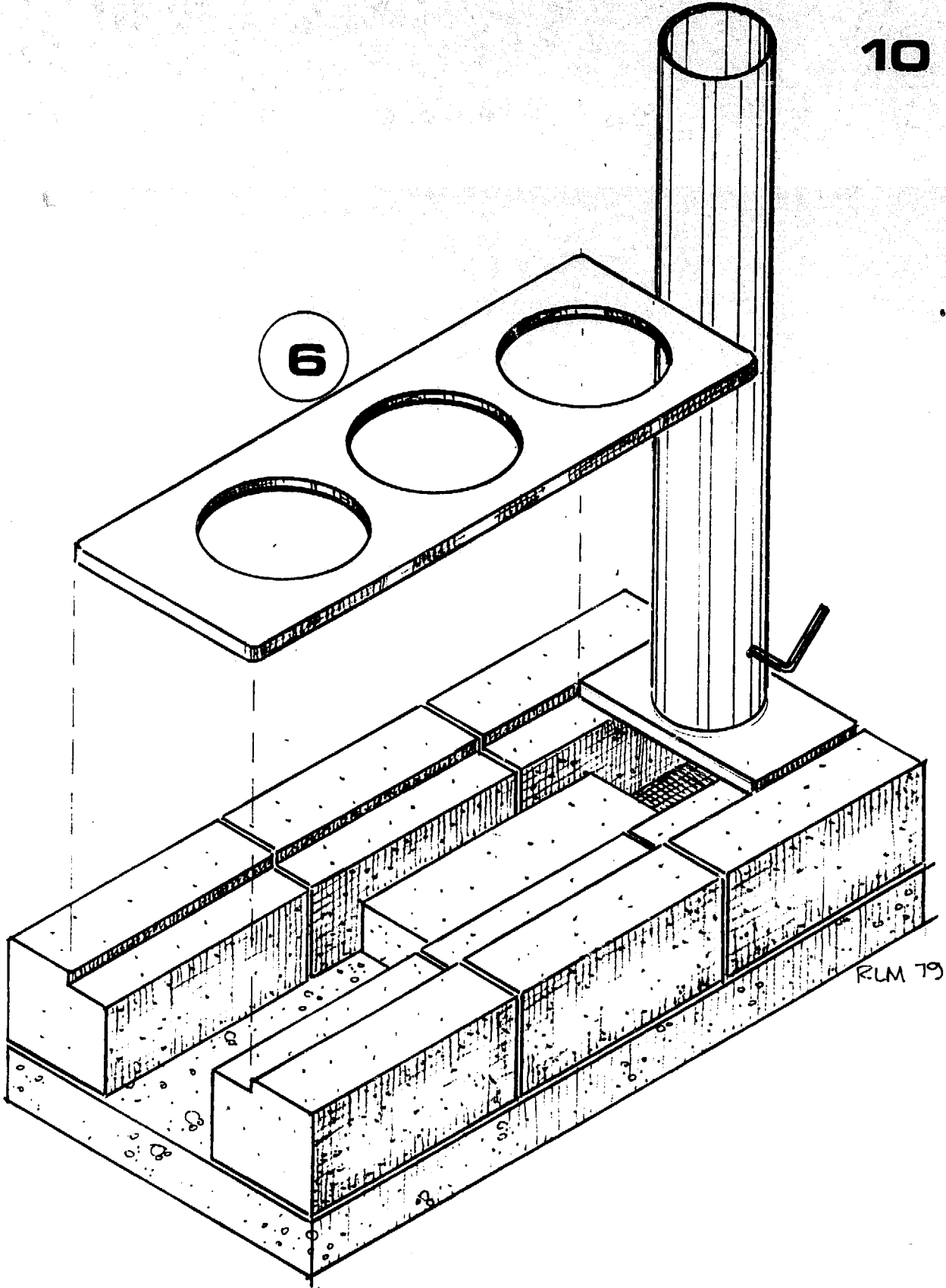

RLM 79



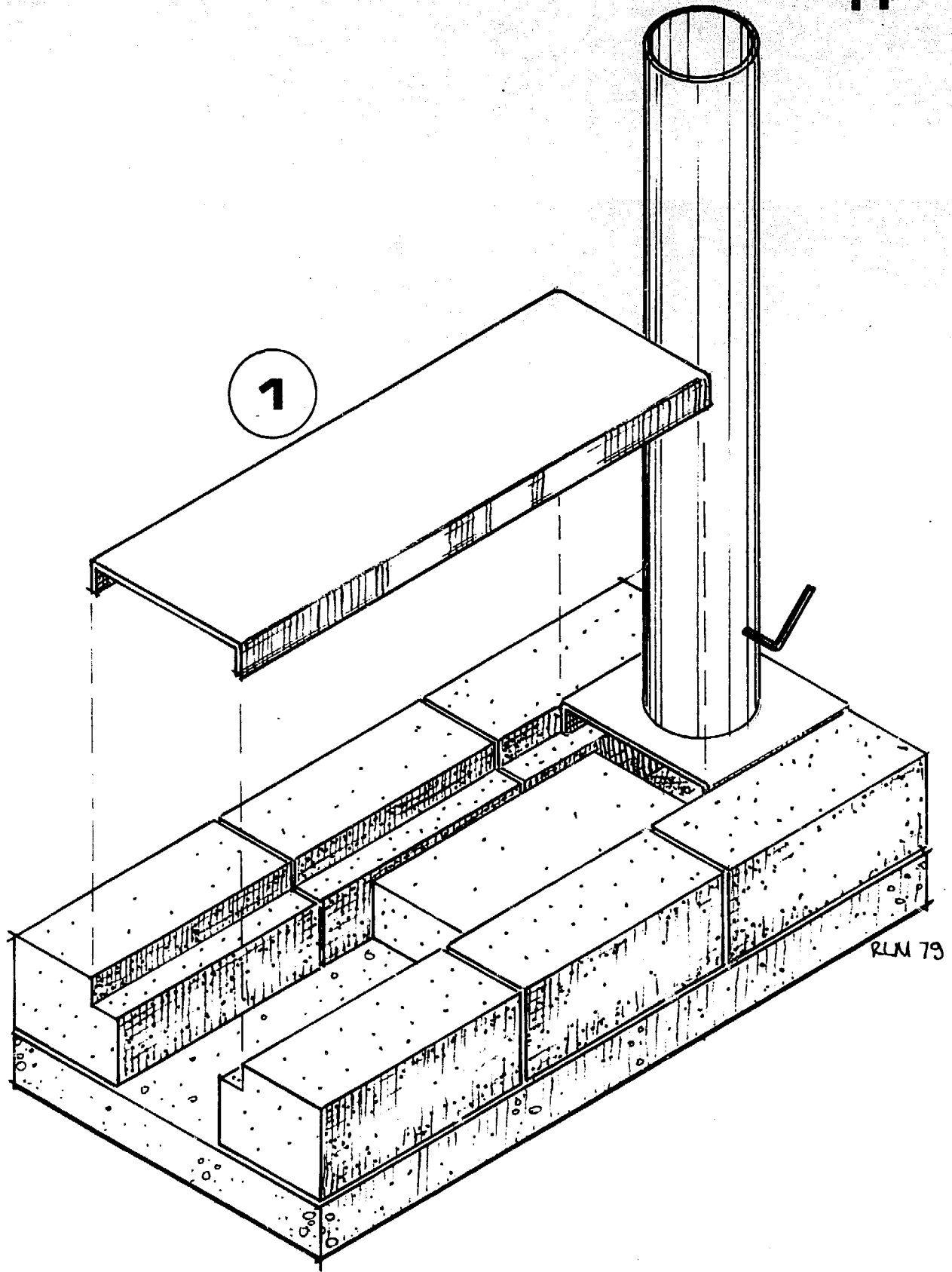

RLM 79

