

**AT** **MICROFICHE  
REFERENCE  
LIBRARY**

A project of Volunteers in Asia

Calculation of Check Dams

by Bernhard Hiller

Published by:

Swiss Association for Technical Assistance  
P.O. Box 113  
Kathmandu  
NEPAL

Available from:

same as above

Reproduced by permission.

Reproduction of this microfiche document in any form is subject to the same restrictions as those of the original document.

7512

DEPARTMENT OF SOIL AND  
WATER CONSERVATION

SWISS ASSOCIATION FOR  
TECHNICAL ASSISTANCE

**Manual**  
*for*  
**Calculation**  
**of**  
**Check Dams**

Kathmandu, Nepal  
September 1979

Prepared by  
BERNHARD HILLER

## S U M M A R Y

---

This manual gives an instrument to engineers to calculate and to design check dams for torrent control under Nepalese conditions. Locally available construction material, the lack of contractors' skill and know-how and the total absence of machinery require a special type of structure: the gravity check dam. This manual shows step-by-step how to proceed in the construction of such a check dam.

C O N T E N T

	<u>Page</u>
Summary	1
Content	2
List of Figures	3
List of Tables	4
0 Introduction	5
I Survey	6
II Estimation of Surface Run-Off	17
III Calculating the Dimensions of Check-Dams	26
IV Construction Materials	49
V Preparation of Control Proposals	59
VI Procedures	62
VII Maintenance	65
VIII Suggestions	68
IX Bibliography	70
 <u>APPENDICES</u>	
1 Estimation of the Largest Stone Size Transported by Water	A1
2 Example of Survey Calculation	A2
3 Example of Run-Off Calculation	A3
4 Example of Check-Dam Design Calculation	A4
5 Example of Cost Estimation	A5
6 Site Instruction for the Assembly and Erection of Gabions	separate

L I S T   O F   F I G U R E S

---

	<u>Page</u>
Fig. 1 The Geometry of Reading Instruments	10
Fig. 2 The Four Readings of the Theodolite	11
Fig. 3 Situation, Fix Points and Instrument Stations	13
Fig. 4 Rainfall Intensity as a Function of the Time of Concentration	19
Fig. 5 A Heavy Storm	20
Fig. 6 Catchment Forms	21
Fig. 7 Nomenclature of Check-Dams	27
Fig. 8 Strain Cases for Check-Dams	28, 29
Fig. 9 Water Pressure Upstream	30
Fig. 10 Scourhole	36
Fig. 11 Placement of Check-Dams in a Bent Torrent	39
Fig. 12 A High Sole Lift with several Check-Dams	41
Fig. 13 Basic Forms of Cross Structures	42
Fig. 14 Basic Forms of Cross Sections	43
Fig. 15 Variation of Cross Section Form	44
Fig. 16 Symmetrical Spillway Sections	45
Fig. 17 Spillway Sole Improvements	45
Fig. 18 Foundation Depths	47
Fig. 19 Construction of a Gabion	56
Fig. 20 Stabilisation of a Gabion by Cross Ties	57
Fig. 21 Filling of a Gabion	58
Fig. 22 Situation, Cross-Sections and Longitudinal Section of a Control Proposal	61
Fig. 23 Network Diagramm of Construction	64

CORRIGENDUM

---

Pages No. 40 and 50 have been  
deleted because the photos  
intended for these pages were not  
available.

L I S T   O F   T A B L E S

	<u>Page</u>
Tab. 1    Stadia Survey	15
Tab. 2    Field Notes and Calculation for Stadia Survey	16
Tab. 3    Intensity Constants	18
Tab. 4    Return Period Conversion Factors	18
Tab. 5    Run-Off-Coefficient	23
Tab. 6    List of some n-Values	24
Tab. 7    Coefficient of Friction	34
Tab. 8    Admissible Bearing Pressure	34
Tab. 9    Specific Weights	35
Tab. 10   Proportions in Concrete Mixtures	54
Tab. 11   Cement Required for Concrete	54

## O I N T R O D U C T I O N

---

The present 'Manual for Calculations of Check Dams' is my final work after 3 years in the 'Department of Soil and Water Conservation' (DSWC) as a technical assistant provided by the 'Swiss Association for Technical Assistance' (SATA).

During the first two years I constructed torrent control check dams with my counterparts. I learnt the local techniques and procedures. With my counterparts and other engineers of the Department I often discussed the problems of check dam construction: local conditions, deep gullies, huge active landslides, bad local construction material, insufficient know-how and skill of the contractors and labourers, the remoteness, the lack of machines, precipitation data and guidelines and the restrictions of small budgets. All this made it difficult or even impossible to construct good permanent check dams.

In the 1978-79 winter I visited all the project areas of the DSWC and made evaluations of check dams ('Evaluation of Check Dams'). This evaluation was a good preparation for writing this manual and to become aware of the separate points.

During their studies in India the engineers received no specific training in the construction of check dams. The available handbooks and reports (see bibliography nos. 3,6,7,8,9 and 10) are not specific enough for Nepalese conditions.

This present manual is one of the guidelines foreseen in the DSWC's 25 year programme.

With this manual I want to give a guideline to the engineers on how to calculate and how to construct check dams. Each chapter is a step in the procedure. A calculated example is shown in the appendix.

The manual is based on the dry masonry - and gabion-check dams with some improvements. It does not treat cement-masonry-, concrete-, R.C.C.- or brush-wood check dams.

In chapter I a general introduction into the survey is given, in chapter II the estimation of surface run-off is shown. Only in chapter III starts the calculating of the dimensions of check dams. In the following chapters the construction material, the preparation of control proposals, the procedure, the maintenance are treated. The manual ends with suggestions, a bibliography and different appendices.

I hope this manual will help to construct good, permanent check dams, for the welfare of Nepal!

Kathmandu, the 12th September, 1979

B. HILLER



1 INTRODUCTION

The reader finds a short general introduction on the theodolite and on tacheometry. In tacheometry you find also the main calculation formulas, in the practical notes a lot of hints for work in the field and in the office. In table 1 you find a chart for the calculations step by step in which all formulas are repeated. You may use this table to make your own chart or to programme your own calculator.

2 THE THEODOLITE

The Theodolite is used to measure horizontal and vertical angles. It is without doubt the most important instrument for exact survey work, and many types are available to meet varying requirements of accuracy and precision, ranging from say the Wild TO Compass Theodolite, with a horizontal circle reading to 1 min, to precision instruments which read directly to 0.5 sec and 0.1 sec. There is thus a wide selection from which to choose to satisfy the surveyor's needs.

Setting Up and Levelling the Theodolite

The instrument must be correctly levelled (thereby making the vertical axis truly vertical) over the station, and in setting up, the footplate should be kept approximately horizontal to prevent excessive movement of the footscrews. The tripod legs can be moved inwards or outwards and sideways, and if a centring device is fitted to the theodolite these legs are moved so as approximately to centre the instrument over the station as indicated. Final centring is carried out using the plumb bob, and the device, which is then clamped. The tripod legs must be firmly pressed into the ground so that no movement can occur in the instrument as the surveyor moves round or when traffic moves nearby, and the wing nuts clamping the legs must be tight. If a centring device is not fitted then more patience will be required in the actual positioning of the tripod legs. Small movements of legs, in pairs at a time, must be made to secure final centring of the plumb bob over the station.

When the instrument has been centred, it must be levelled. Assuming three footscrews only, and using the bubble on the horizontal vernier plate, the procedure is as follows -

(a) Rotate the inner axis so that the bubble tube is parallel to two of the footscrews. Turning these footscrews, the bubble is brought to the centre of its run. The footscrews are turned simultaneously with the thumbs moving towards each other or away from each other. The left thumb movement gives the direction of the consequent movement of the bubble.

(b) Rotate the inner axis so that the bubble tube is at right angle to its former position, when it should be parallel to a line joining the third footscrew to the mid-point of the line joining the other two. Bring the bubble to the centre of its run using the third screw only.

A correctly-adjusted instrument will now be levelled, and as the vernier plate rotates and takes the bubble tube round, then the bubble should remain at the centre of its run. In practice, the above procedure is carried out at least twice, the telescope being wheeled successively through  $90^\circ$  back to position (a) and then after checking with the two screws, to position (b).

The instrument is now set up ready for the measurement of horizontal angles.

### Measurement of Horizontal Angles

To measure angle ABC, the instrument is set up over station B in the manner described, and carefully levelled by means of the footscrews. The face of the instrument must be checked at this stage. Most telescopes have sights similar to those on a gun, fitted on top of the barrel, to assist in sighting the target. With these sights on top and the telescope pointing to the target, the vertical circle, which is known as the face of the instrument, will be left or right of the telescope. Suppose it is to the left; the theodolite is said to be in the face left position. By rotating the telescope through  $180^\circ$  in the vertical plane (i.e. about the trunnion axis), and then through  $180^\circ$  in the horizontal plane, the telescope will again be pointing at the signal, but the gunsights will be on the underside of the barrel, and the vertical circle to the right - i.e. the theodolite is in the face right position. Starting with all clamps tightened, then -

(a) The lower plate will now be unclamped and the telescope directed so that A appears in the field of view; turning the telescope moves the scales. Exact coincidence of the vertical crosshair upon A is obtained by means of the lower tangent screw. The readings may now be taken. It is helpful, if this first reading is near zero.

(b) With the lower clamp fixed, the upper clamp will be freed, and the telescope directed towards C, a rough setting being obtained by hand, the upper clamp is then applied, and coincidence on the vertical hair is obtained by means of the upper tangent screw.

(c) The readings are again noted and the angle value is found. In theodolite traverse surveying other readings will be taken to increase the accuracy of the measurement. The face of the instrument may be changed so as to obtain several values for the same angle and a mean is then computed. Taking the mean of face left and face right readings will eliminate the errors caused if the permanent adjustments 2 and 3 have not been carried out correctly.

It is advisable to sight the intersection of the cross-hairs as near as possible to the bottom of the observed signal to reduce to a minimum any effects due to that signal, perhaps a ranging rod not being vertical. Ensure that the lower clamp or tangent screw is not disturbed after setting the instrument in position, otherwise the scale plate maybe moved and a false reading obtained.

### Measurement of Vertical Angles

The angles of elevation or depression are measured with respect to the horizontal plane containing the trunnion axis of the instrument. Assuming, as in the previous section, that the permanent adjustments have been checked, then

the instrument will be set up and levelled, over the station, using the plate bubble. The altitude bubble on the vertical circle should now be nearly, if not quite, central. Level up this bubble using the levelling screws, and wheel through  $180^{\circ}$  to see whether the bubble "traverses". If it does not, take out half the bubble displacement on the clip screws and the other half on the levelling screws. Repeat until the bubble traverses.

The telescope is now directed to one of the signals and the exact coincidence on the mark obtained, using both horizontal and vertical slow-motion devices. The reading of the vertical plate will now give the angle subtended by the signal at the instrument relative to the horizontal plane. If the telescope is directed to the other signal, obtaining coincidence as before, the reading to the other will give that vertical angle which the two signals subtend at the instrument. It is immaterial whether the signals are in the same vertical plane or not, as long as the instrument is in adjustment.

### Permanent Adjustments of the Theodolite

The following adjustments may be required -

- (1) To set the vertical axis of the instrument truly vertical and to adjust the plate bubble.
- (2) To set the telescope sighting line at right angles to the horizontal or trunnion axis of the instrument.
- (3) To set the horizontal axis at right angles to the vertical axis.
- (4) To adjust the altitude bubble and the vertical circle zero.

An analysis of the errors caused by failure to make these adjustment correctly may be found in the literature.

### Modern Instruments

This section gives a brief outline of some instruments now being manufactured which are somewhat different from the ordinary theodolite described earlier in the chapter.

The Centesimal System. In this chapter so far angular measurements have been referred to circles with major graduations from  $0^{\circ}$  to  $360^{\circ}$  with secondary graduations which subdivide each degree into 10 minute intervals. Vernier or micrometer subdivisions then give the reading down to seconds, and since there are sixty minutes in a degree and sixty seconds in a minute, the system is known as the sexagesimal system (Latin: sexaginta = sixty). It is possible, however, to obtain instruments graduated in 400 major parts from  $0^g$  to  $400^g$  (read as 400 grade). The grade is subdivided into five intervals each of 20 minutes and since there are 100 minutes to the grade on this system it is known as the centesimal system (Latin: centum = hundred). Angles can be expressed as decimals on this system.

Glass Circle Theodolites. The instruments now to be described differ greatly from the vernier instrument previously described in that the metal scale plates read by vernier are replaced by glass circles which are read by means of internal optical systems. The circles provided in modern theodolites are photographic copies of glass master circles which in turn have been graduated by means of an automatic dividing machine.

Another feature of modern theodolites worthy of note is that most telescopes are provided with focusing rings or sleeves on the telescope barrel near to the eyepiece, These replace the knurled focusing screw previously fitted at the trunnion axis level outside one of the standards.

### 3 THE OPTICAL MEASUREMENT OF DISTANCE (TACHEOMETRY)

In this branch of surveying, heights and distances are determined from the instrumental readings alone, these usually being taken with a specially adapted theodolite known as a tacheometer. The chaining operation is eliminated, and tacheometry is therefore very useful in broken terrain, e.g. land cut by ravines, river valleys, over standing crops, etc., where direct linear measurement would be difficult and inaccurate. All that is necessary is that the assistant, who carries a staff on which the tacheometer is sighted, shall be able to reach the various points to be surveyed and levelled, and that a clear line of sight exists between the instrument and the staff. An additional limitation is imposed in some branches of tacheometry in that the distance between staff and instrument must not exceed a maximum, beyond which errors due to inaccurate reading become excessive.

The field work in tacheometry is rapid compared with direct levelling and measurement (the name derives from the Greek swift and measure), and it is widely used therefore to give contoured plans of areas, especially for reservoir and hydro-electric projects, tipping sites, road and railway reconnaissance, housing sites, etc. With reasonable precautions the results obtained can be of the same order of accuracy as, or better than, those obtainable by direct measurement in some cases.

#### Systems of Tacheometry

Present-day methods of tacheometry can be classified in one of the following three groups -

1. The theodolite, with the measuring device inside it, is directed at a levelling staff which acts as target. This is usually known in England as the stadia system. One pointing of the instrument is required for each set of readings.

2. An accurate theodolite, reading to 1" of arc, is directed at a staff, two pointings are made, and the small subtended angle is measured. There are two variants, depending on the staff used, (a) an ordinary levelling staff, held vertically, is used - known as the tangential system, or (b) a bar of fixed length, usually held horizontally, is used - known as the subtense system.

3. A special theodolite with a measuring device in front of the telescope is directed at a special staff. One pointing of the instrument is required for each set of readings - the optical wedge system.

#### The Stadia System

There are two types of stadia instruments, (A) in which the distance between the two hairs is fixed, and (B) those in which the distance is variable, being measured by means of a micrometer. These latter, which are sometimes described as subtense tacheometers, are not so common as the fixed-hair types, and will be dealt with only briefly. Fixed-hair tacheometry, or stadia surveying as it is often called, is dealt with at some length.

#### Inclined Sights

Although a stadia survey could be carried out with the telescope level, work would be tedious in broken and hilly terrain, and since it is on such ground

that the tachometer comes into its own, we see that the basic formula  $D = Cs + K$  must be modified to cover the general case when the line of sight is inclined to the horizontal.

With Vertical Staff

From Fig 1 where A, C and B are the readings given by the three lines, and A', C' and B' are those which would be given if the staff were normal to the line of collimation.

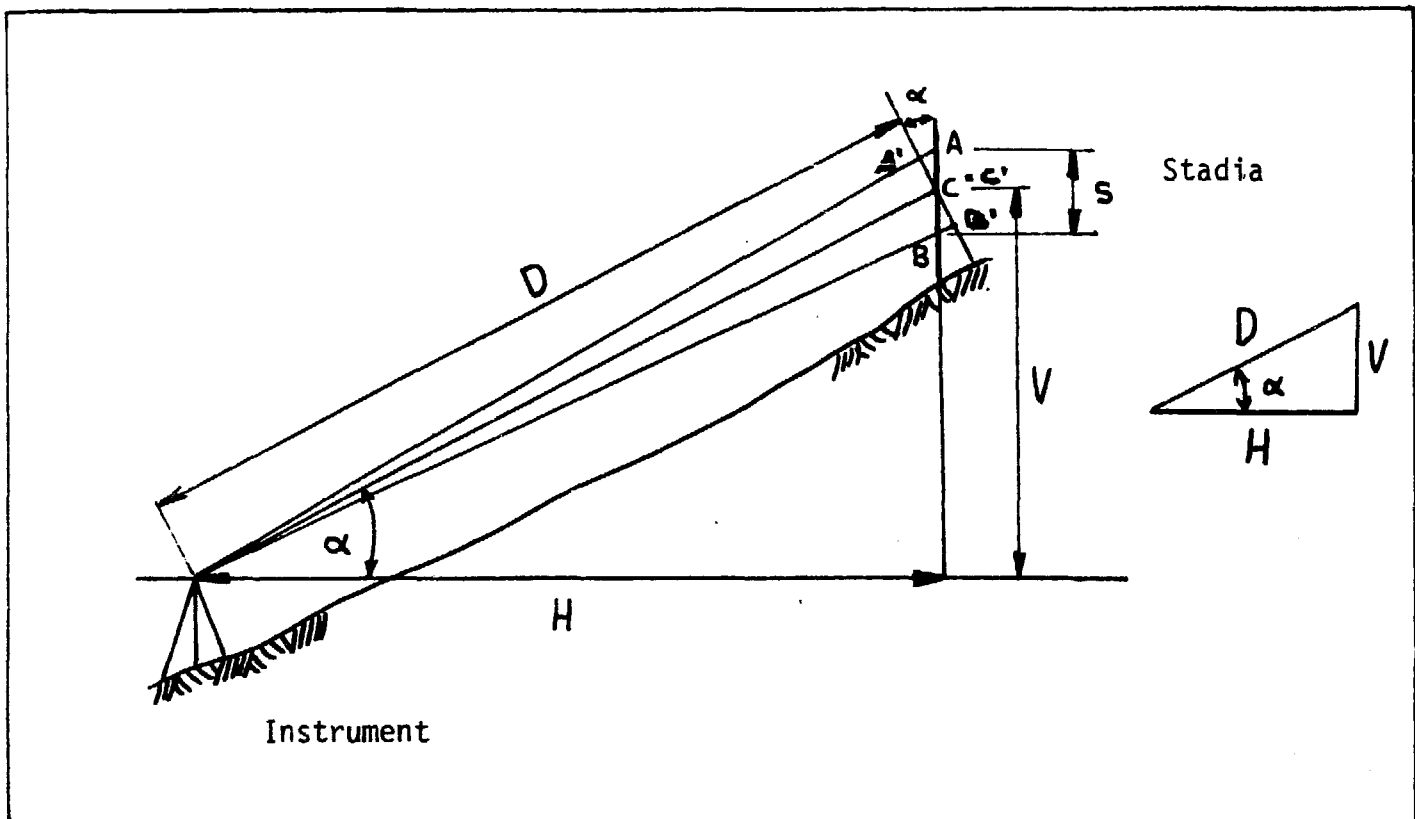

Fig. 1 The Geometry of Reading Instruments

Legend

- A: upper stadia-reading
- B: lower stadia-reading
- C: middle stadia-reading
- s: difference between upper and lower stadia-reading,  $s = A - B$
- $\alpha$ : vertical angle from the horizontal line to the view
- D: Inclined distance from the instrument to the middle staff-reading
- H: horizontal or reduced distance
- V: vertical distance or height difference between middle stadia-reading and instrument
- k: constant according the fixed hairs (50 or 100)

Formation for the Calculation

$$\begin{aligned}
 D &= C(A'B') + K \\
 A'B' &= AB \cos \alpha \text{ (assuming } \widehat{CA'A} = \widehat{CB'B} = 90^\circ) = s \cos \alpha \\
 D &= ks \cos \alpha + K \\
 H &= D \cos \alpha \\
 &= ks \cos^2 \alpha + K \cos \alpha \\
 V &= D \sin \alpha \\
 &= ks \cos \alpha \sin \alpha + K \sin \alpha \\
 &= \frac{1}{2} ks \sin 2\alpha + K \sin \alpha
 \end{aligned}$$

The importance of the analytic condition, i.e.,  $K = 0$ , in simplifying the reduction of readings is readily seen, but in most modern instruments where  $K$  is very small, if not actually zero, the following approximations are justified:

$$\begin{aligned}
 H &= ks \cos^2 \alpha \\
 V &= ks \frac{1}{2} \sin 2\alpha
 \end{aligned}$$

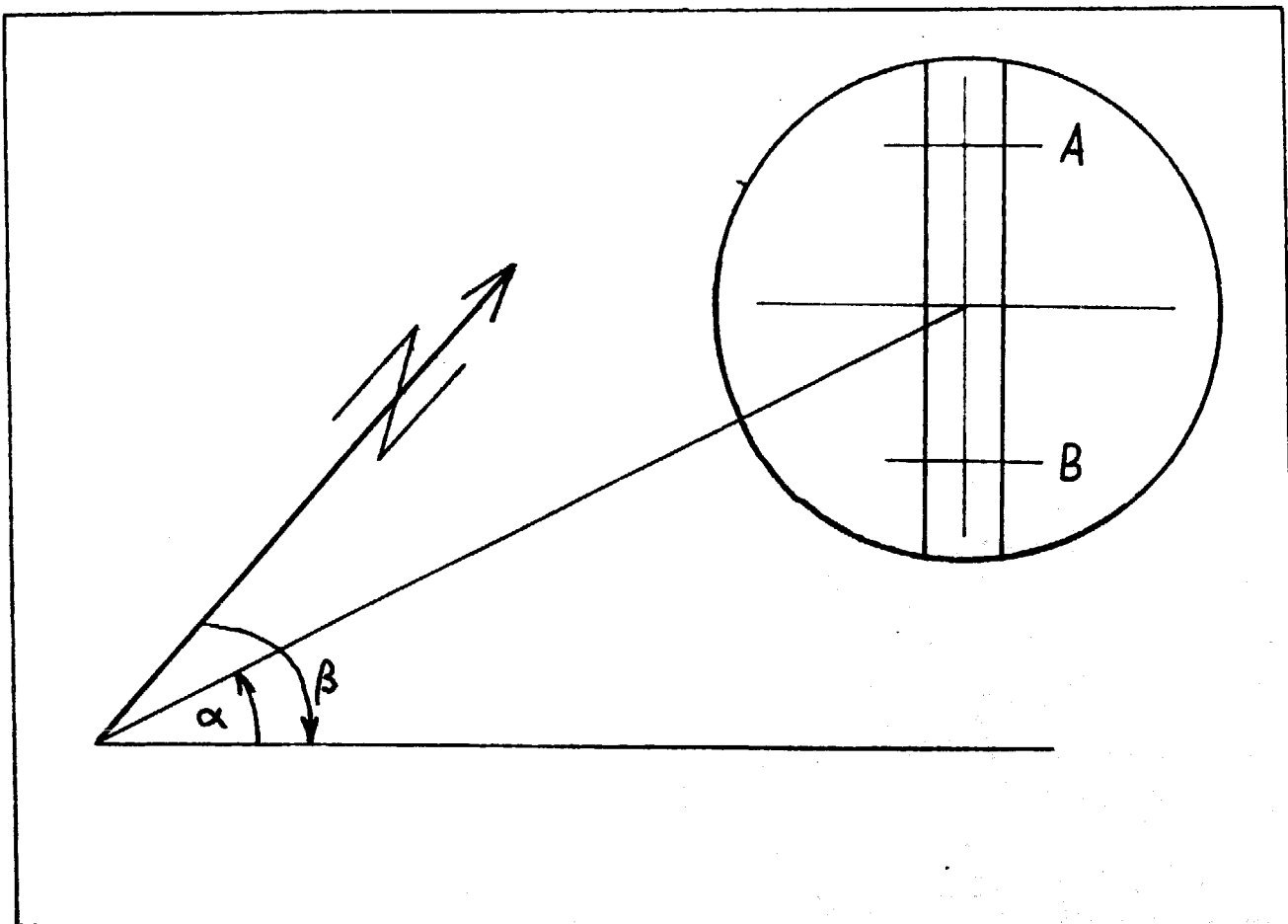

Fig. 2 The Four Readings of the Theodolite

- 1) A, the upper stadia reading
- 2) B, the lower stadia reading
- 3)  $\alpha$ , the vertical angle, read after properly levelling with the bubble, in the vertical scale
- 4)  $\beta$ , the horizontal angle, read on the horizontal scale

For reading 3 and 4, the staff can already be removed!

4 PRACTICAL NOTES

Before starting the survey, plan the details:

- For the situation (1:500 - 1:2000) which area and which details must be surveyed? (gully, rivulets, spring, paths, houses, big stone, pipal tree etc., see Fig 3)
- Where are the cross-sections and how many are taken?
- According to the needs of the two above mentioned points, the positions and number of instrument stations are fixed.
- Base the survey on one fix point (height = 0.00, X = 0.00, Y = 0.00). Strengthen the system (instrument stations and fix point) with the measurement from every system point to each of the others. Otherwise the measurement of each station is loose which means there is no orientation in distance, direction and height towards the others. Another solution to get a good survey net is to make a field angle traverse from one fix point to another one. This method gives the best result.
- Instrument: Is the index  $360^{\circ}$  or  $400^g$ ? Is 0 in the vertical angle at the top or at the bottom? This changes the calculation procedures! Note the type and serial number of the instrument.

Procedure at every instrument station

- Set and level the instrument.
- Note the instrument height.
- Describe every measured point, for instance:  
3rd cross-section, 2nd point from left, 2 m high stone or fix point A at the gully side, big stone with mark
- Take the following measurements for every point (Fig.2.):
  - $S_u$ : upper stadia reading
  - $S_l$ : lower stadia reading
  - $\alpha$ : vertical angle
  - $\beta$ : horizontal angle

These 4 (four) items are necessary, all the rest can be calculated in the office.

Calculation Procedure

The calculation may be made with

- a) trigonometrical charts and slide rule
- b) calculator with trigonometrical functions
- c) programmable calculator

The calculation procedure a) and b) needs a calculation chart, in which every single item can be noted. An example is shown in table 1.

For the calculation procedure c) the engineer must know the calculator and its functioning very well. A foolproof programme is needed. If you are not very familiar with a programmable calculator, do it another way.

Here are some hints for the programmable calculator:

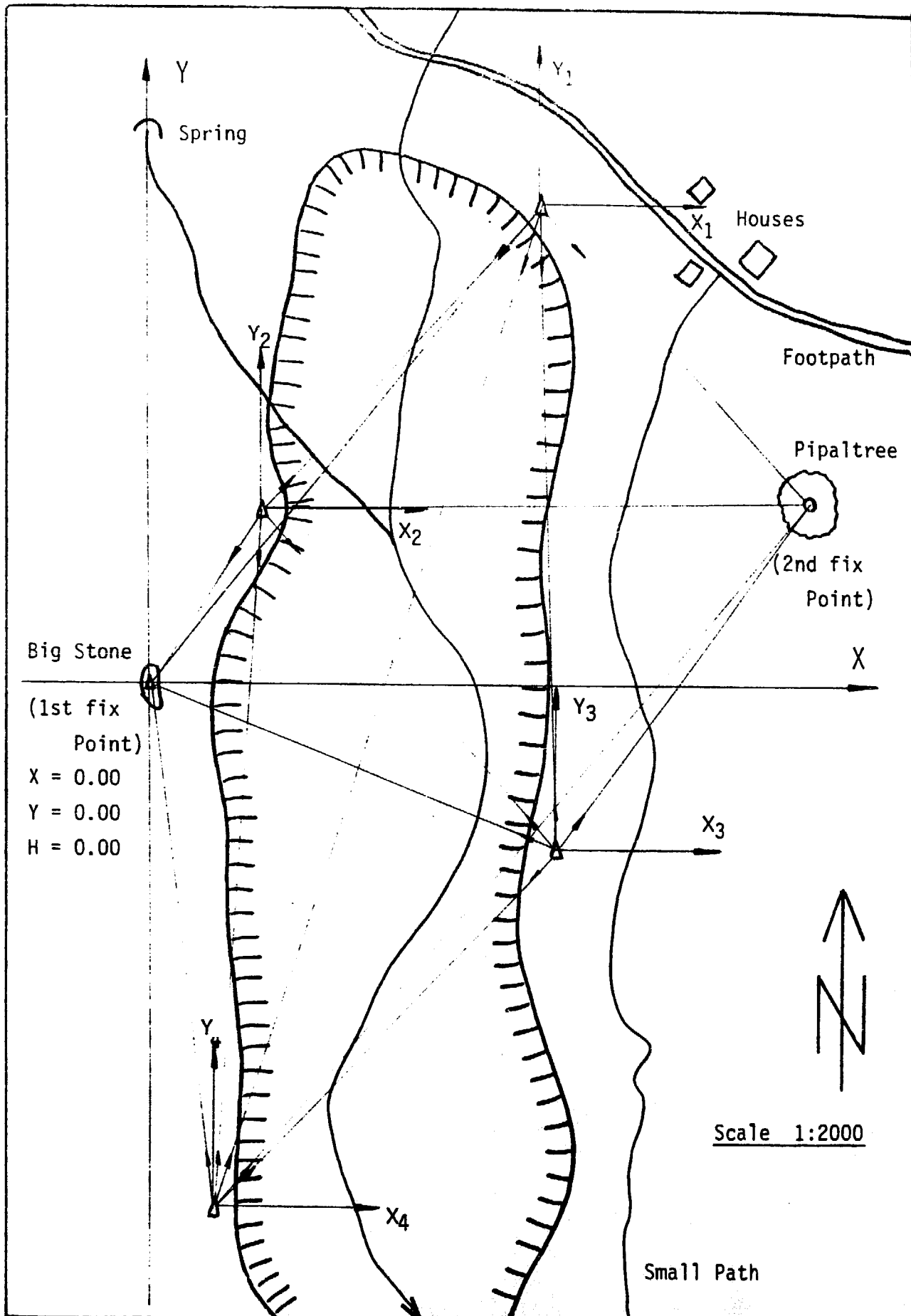

Fig. 3

Situation, Fix Points and Instrument Stations



- Normally they have a function from polar coordinates (P) into rectangular coordinates (R) and vice versa. So the calculation procedure can be shortened:

1)  $D = 100 \cdot (S_u - S_1) \cdot \cos \alpha$

2)  $(D, \alpha) \xrightarrow{\text{R}} (H, V)$   
polar rectangular

3)  $(H, \beta) \xrightarrow{\text{R}} (X, Y)$  (coordinates of the point in respect to the station) For programmable calculators the chart in table 2 is recommended.

### Drawing

It is more convenient to plot rectangular coordinates (X,Y) on graph papers as a polar coordinate (H,β) with protractor and ruler in the situation. So it is worth while to make the calculation for X and Y, especially if you have a programmable calculator!

Table 1

Stadia Survey

Place ..... Example .....  
 Surveyed by .....

Project ..... Manual .....  
 Calculated by ..... B. Hiller .....

Date ..... 9th of September, 1979 .....  
 Checked by .....

Station	Sight Point	Stadia Reading		Stadia Interval $S = S_u - S_l$	Vertical Angle $\alpha'$	Red. Vert. Angle $\alpha$	$\cos \alpha$	$\cos^2 \alpha$	Distance D $100S \cos^2 \alpha$	sin. $2\alpha$	$\Delta h'$ $100 S \frac{1}{2} \sin 2\alpha$
		upper $S_u$	lower $S_l$								
*	*	*	*		*						
1	2	3	4	5	6	7	8	9	10	11	12
A	stone waterrill	2.38	1.93	0.45	$97^{\circ}46'30''$	$7.275^{\circ}$	0.992	0.984	44.28	0.251	5.653
		1.24	1.03	0.21	$86^{\circ}17'50''$	$-3.897^{\circ}$	0.998	0.995	20.90	-0.135	-1.424
Height of Instrument $h_i$	Stadia Middle $s_m$	$\Delta h$ $\Delta h + h_i - s_m$	Horizontal Angle $\beta$		X $D \sin \beta$	$\cos \beta$	Y $D \cos \beta$	Remarks			
*	*		*								
13	14	15	16	17	18	19	20	21			
1.35	2.16	4.843	$130^{\circ}24'20''$	0.764	33.85	-0.645	-28.55				
1.35	1.14	-1.214	$325^{\circ}07'10''$	-0.573	-11.97	0.820	17.13				
* these data must be noted in field!											

Table 2 Field Notes and Calculation for Stadia Survey  
(with programmable calculator)

Place ..... Project ..... Date ..... Page .....

Field							Office			
Stn	Point	H <sub>i</sub>	S <sub>u</sub>	S <sub>l</sub>	$\alpha'$	$\beta$	$\Delta h$	D	X	Y
A	stone	1.35	2.38	1.93	97°46'31	130°24'2	4.84	44.28	33.85	-28.55
	rill	1.35	1.24	1.03	86°17'53	25°07'1	-1.21	20.90	-11.97	17.13

## II THE ESTIMATION OF SURFACE RUN - OFF

---

### 1 QUANTITIES AND RATES OF RUN-OFF

Before a start can be made on the design of channels, ditches and other works which have to deal with surface run-off, it is necessary to have information on the probable quantity of water. If the object is to impound or store the run-off then it may be sufficient to know the total volume of water to be expected. Usually the conservation problem is that of conveying water from one place to another, and in this case the rate of run-off is more important, particularly the maximum rate at which run-off is likely to occur. This is the flow which a channel must accommodate.

In a hypothetical catchment area with an impervious surface and no losses the maximum rate of run-off would be directly proportional to the rate of rainfall. In natural catchments there are other factors; some of the rain is intercepted by vegetation, some infiltrates into the soil, some starts moving over the surface but is trapped in depressions, and some is lost by evaporation. These and many other factors are like alternative diversions from the main route which is rainfall becoming surface run-off. Estimates of rates of surface run-off therefore all depend upon two processes: an estimate of the rate of rainfall, and an estimate of how much of the rainfall becomes run-off.

### 2 THE RATIONAL FORMULA

The rational formula is the simplest method and depends on the area, the intensity and a factor. The intensity must be calculated from the time of concentration. In the following section two different ways of intensity calculation and the estimation of the time of concentration are shown.

#### 2.1. Intensity (based on generalized rainfall intensity duration-frequency formula)

It is a common experience that the most severe rainfall only lasts for a short time. A storm which lasts for several hours will usually give a greater total amount of rain than a storm which lasts for few minutes only, but the average rate of rainfall, expressed in mm per hour, will usually be less than the average rate for the short storm. The length of a storm is called its duration, and the relationship between intensity and duration is shown in the formula

$$I = \frac{a}{t + b}$$

where  $I$  is the average intensity of the storm in mm/h  
 $t$  is the duration of the storm in minutes  
 $a$  and  $b$  are constants, see Table 3

Table 3 Intensity Constants

Rainfall equalled or exceeded once in	a	b
6 months	500	4
1 year	830	5
2 years	1400	7
5 years	2100	9
10 years	2590	10
20 years	2850	10
50 years	3220	11
Enveloping curve	7820	34

2.2. Intensity ( based on local observations)

For three stations in the hills of Nepal (Kathmandu, Okhaldunga, Pokhara) maximum rainfall observations were available, being observations of 5 min., 10 min., 30 min., 1 hr., 2 hr., 6 hr., 12 hr., 1 day, 1 month. I plotted these observations on a graph paper and obtained three parallel lines (see Fig. 4). From the catchment area itself or from the next meteorological station it is possible to get the highest 24 hours precipitation. The number of the observation years gives the probability of the occurrence of the 24 hour precipitation obtained. Make a parallel line on the graph with this value until you will reach the desired time of concentration and you will get the appropriate intensity. This intensity has still the same occurrence probability. To change it, use the factors given in Table 4.

Table 4 Return Period Conversion Factors

Years	Factor
2	0.90
5	0.95
10	1.00
25	1.25
50	1.50

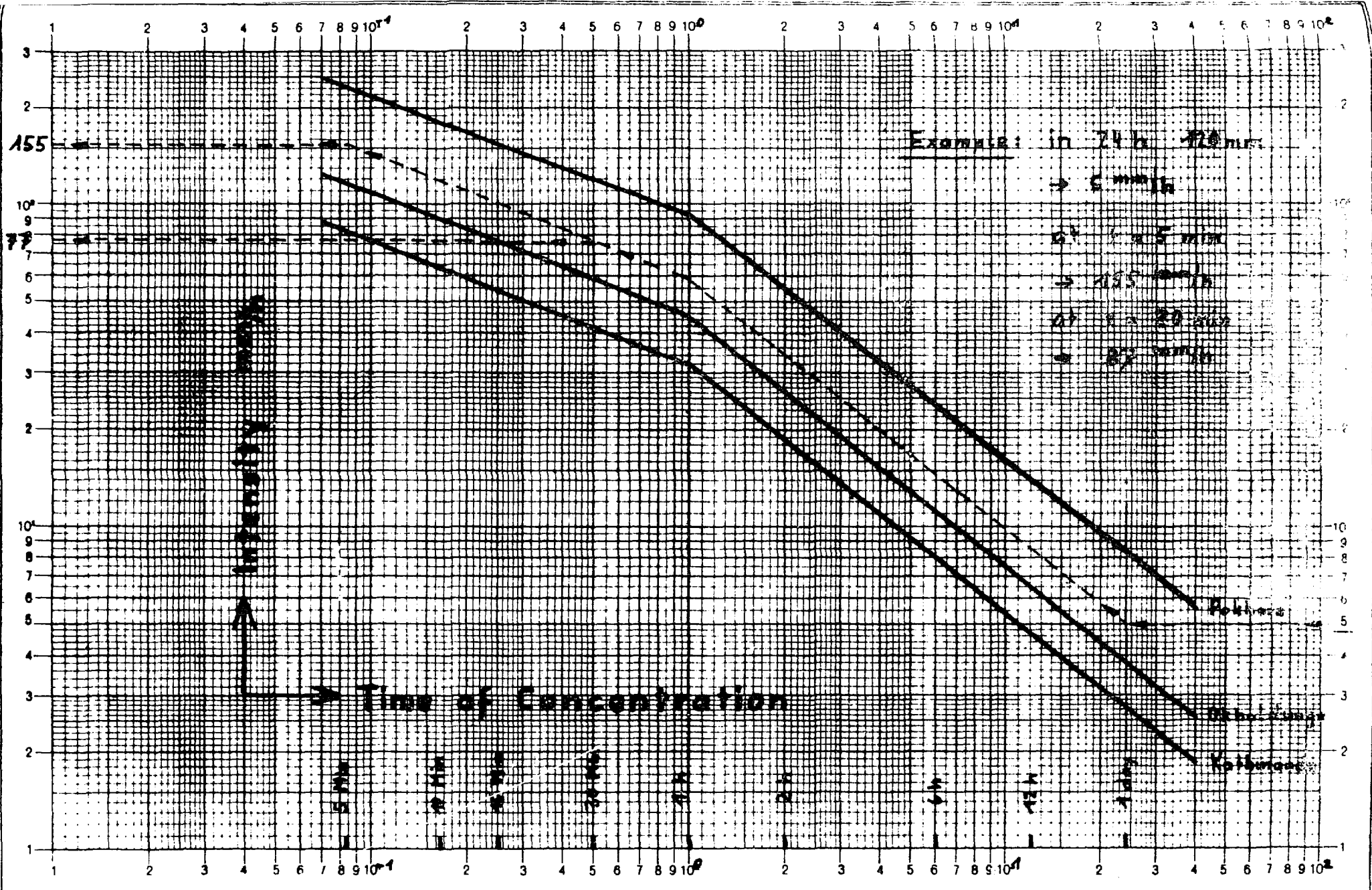

Logar. Teilung | 1-300 u. 1-10000 Einheit | 62,5 mm  
 Division | Unité |

Ed. Aerni-Leuch, Bern, Nr. 551

Fig. 4 Rainfall Intensity as a Function of the Time of Concentration

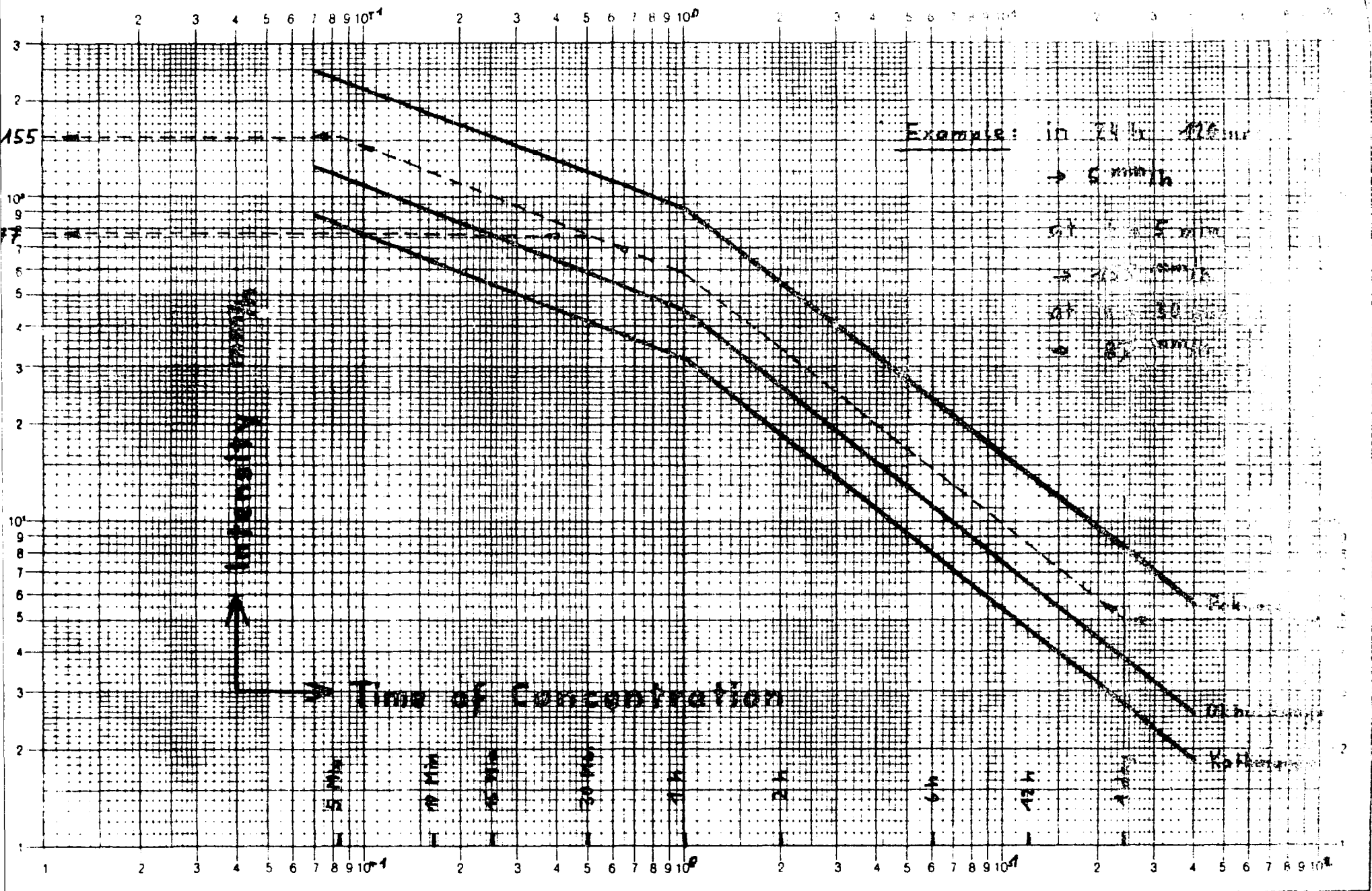

Logar. Teilung / 1-300 u. 1-10000 Einheit / 62,5 mm  
 Division / Unité /

Ed. Aebi-Leuch, Bern, Nr. 551

Fig. 4 Rainfall Intensity as a Function of the Time of Concentration

### 2.3. Time of Concentration

The storm duration which will correspond with the maximum rate of run-off is known as the time of concentration or the gathering time. It is defined as the longest time taken for water to travel by overland surface flow from any point in the catchment to the outlet. The reason why this time corresponds with the maximum flow is best illustrated by considering the catchment shown in Fig: 5.

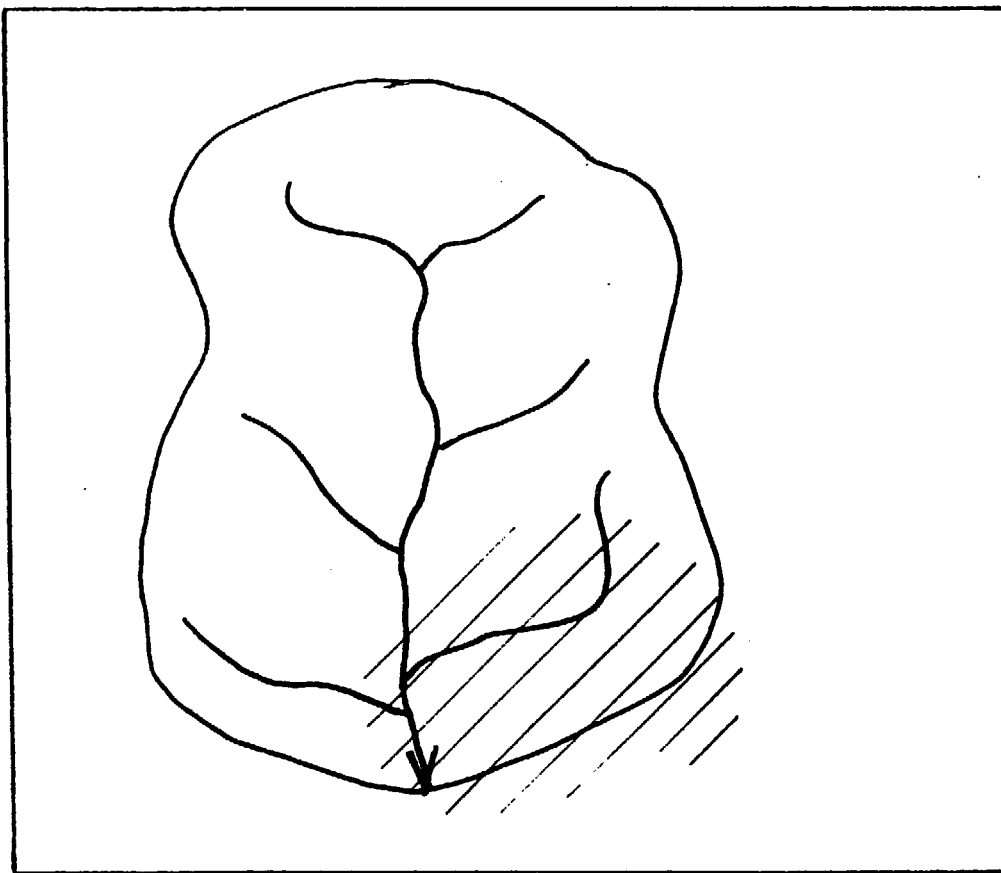

Fig. 5 A heavy storm on part of the catchment does not give maximum flow

If a severe but localized storm falls in the lower shaded part of the catchment the run-off will be proportional to the product of the intensity and the area on which the storm falls. The intensity could be high but only a portion of the catchment area is receiving rain and yielding run-off. If a more widespread belt of rain covers the whole area the intensity will probably be lower, but the whole catchment area will be yielding run-off. It has been found that for normal catchments this second situation of a storm covering the whole catchment, always gives a greater maximum rate of run-off. Maximum run-off will therefore result when the whole catchment is yielding



run-off at the maximum rate it can do so. Since the intensity/duration curves show that intensity decreases as duration increases, the maximum rate of rainfall, and hence the maximum rate of run off, will occur in a storm with the shortest duration which will still allow the whole catchment to contribute run-off. The shortest time for the whole catchment to contribute is the time it will take water to flow from the point in the catchment which is farthest away in time, hence the definition of concentration time. The longest time may not necessarily be that taken by run-off from the farthest point to reach the outlet, for there may be a nearer point which because of flatter grades or storage has a slower route to the outlet. This possibility is taken care of by the definition specifying the longest time for run-off to flow from a point in the catchment to the outlet.

The main variables affecting the time of concentration of a catchment are

- 1) Size: the larger the catchment the longer will be the gathering time.
- 2) Topography: steep topography will cause faster run-off and a shorter gathering time than a flatter catchment.
- 3) Shape of the catchment. In Figure 6 the two catchments have the same area and both have a symmetrical drainage pattern but the longest distance to the outlet is greater in one than in the other. The gathering time will therefore be longer, the corresponding intensity lower, and the maximum rate of run-off less. This is the explanation of the fact that, all other factors being equal, long narrow catchments tend to have less flashy floods than square or round catchments.

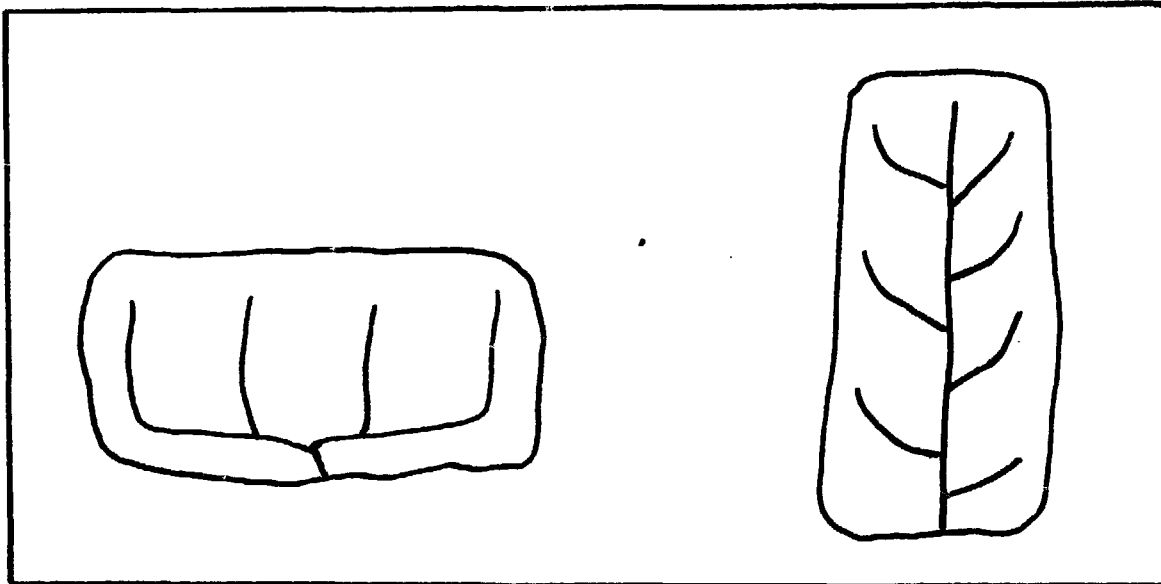

Fig. 6 A short squat Catchment has a shorter gathering Time than a long narrow Catchment

An accurate method is the Bransby-Williams formula.

$$T = \frac{L}{1.5 D} \cdot \sqrt{\frac{A^2}{J}} = \frac{L}{1.5 \sqrt{A \frac{4}{TL}}} \cdot \sqrt{\frac{A^2}{J}}$$

Where T is the time of concentration in hours  
 L is the longest distance from the outlet in kilometers  
 D is the diameter of a circle equal in area to the catchment area in kilometers  $D = \sqrt{A \frac{4}{TL}}$   
 A is the actual area in square kilometers  
 J is the average fall of the main watercourse in meters per 100 metres distance

#### 2.4. The Rational Formula

The simplest method to estimate the maximum of run-off is the Rational-Formula which is

$$Q = \frac{C I A}{360}$$

Where Q is the rate of run-off in cubic metres per second  
 I is intensity in mm per hour  
 A is the catchment in hectares  
 C is a dimensionless constant, the run-off coefficient (see 2.5)

The popularity of this method is enhanced by the fortunate numerical coincidence which makes C dimensionless in spite of the other three items being in various units.

The application of the formula consists of selecting appropriate values of C, I and A. The area A can be measured, by survey or from maps or aerial photographs. The value of intensity I the maximum rate of rainfall, is determined as shown in section 2.1. and 2.2. from consideration of the time of concentration for the catchment, and the probability. Estimates of the coefficient C must be considered next.

#### The Run-Off Coefficient

The proportion of rain which becomes run-off depends on many factors: the topography, the vegetation, the infiltration rate, the soil storage capacity, the drainage pattern, and so on. It is at the same time the virtue of the Rational formula and its weakness that all these factors are combined into a single run-off coefficient C.

Table 5 Run-Off Coefficient

Catchment Characteristics	C
Steep, bare rock	0.90
Rock, steep but wooded	0.80
Plateaus lightly covered, ordinary ground, bare	0.70
Clayey soils, stiff and bare	0.60
Clayey soils, lightly covered	0.50
Loam, lightly cultivated or covered	0.40
Loam, largely cultivated	0.30
Sandy soil, light growth	0.20
Sandy soil, covered, heavy bush	0.10
Jungle areas	0.10 - 0.20

3 THE MANNING FORMULA

A practical formula to get good results from field observations is the Manning Formula. The run-off estimation is calculated from the reverbed characteristics.

$$v = \frac{1}{n} R^{2/3} J^{1/2}$$

$$Q = vA = \frac{1}{n} R^{2/3} J^{1/2} A$$

$$R = \frac{A}{U}$$

$$Q = \frac{1}{n} \frac{A^{2/3}}{U^{2/3}} J^{1/2} A$$

$$Q = \frac{1}{n} \frac{A^{5/3}}{U^{2/3}} J^{1/2}$$

where Q is the run-off at the measure site in m<sup>3</sup>/sec  
 n is the roughness-coefficient specially known as Manning's n, see Table 6  
 J is the gradient of the river in m/m  
 U is the wet surface of the river in m  
 A is the cross sectional area of the river in m<sup>2</sup>

Remark: This formula is not accurate for rivers with a lot of bedload or with mudflow (the specific weight of the water is changing!)

In the field the following observations must be noted:

- character of the riverbed according to Table 6
- gradient of the river in m/m (arc tgα), with clinometer
- wet surface of the river in m, with measurement tape and level
- area (cross section of the river) in m<sup>2</sup>, with measurement tape and level

This formula may be used in a firm channel where the level of the last highest peak run-off can easily be recognized!

Table 6 List of some n-Values

Riverbed Characteristics	n-value	
	Range	Mean
<b>A</b> <u>Rills in the Plain</u>		
- Clean, plain sole, straight (sand-gravel-sole)	0.0333 - 0.0250	0.0300
- ditto with stones and bank-trees	0.0400 - 0.0300	0.0350
- Clean, turned, some gravel banks and holes	0.0440 - 0.0333	0.0400
- ditto, more stones, trees	0.0500 - 0.0350	0.0455
- ditto, irregular bank, uneven small fall-steps	0.0555 - 0.0400	0.0475
- ditto with more stones	0.0625 - 0.0425	0.0500
- ditto, with backwater, deep holes and trees on banks	0.0833 - 0.0500	0.0710
- ditto, very bushy on banks	0.1666 - 0.0769	0.1000
<b>B</b> <u>Rills in the Mountains</u> (no vegetation, very steep slopes)		
- sole: gravel, stones and some blocks	0.0500 - 0.0300	0.0400
- sole: stones and big blocks	0.0710 - 0.0400	0.0500
- blocksole, very irregular, partly looking out of the water, with small falls	0.1000 - 0.0666	-
<b>C</b> <u>Torrents, at High Water</u> (estimated values at not controlled torrents)		
- coarse gravel sole with stones, straight	0.0500 - 0.0400	-
- ditto, very curvy, sole and bank irregular	0.0666 - 0.0500	-
- stone sole with single blocks, sole and banks irregular	0.0833 - 0.0590	-
- blocksole, sole and bank very irregular many bottlenecks, rapids, holes	0.1250 - 0.0666	-
- ditto, with strong trees and bushes	0.2000 - 0.0833	-

Remarks: The n-value can change within short distances in torrents. They often change during high flood. The formula by Manning may not be used when the water

EMPIRICAL RELATION

If the run-off in a catchment which is part of a bigger catchment with a known run-off has to be calculated, or where the run-off of an adjacent catchment is known, the empirical formula may be used, if the meteorological conditions and the catchment characteristics are the same:

$$\frac{Q_1}{Q_2} = \frac{\sqrt{A_1}}{\sqrt{A_2}} \qquad Q_1 = Q_2 \frac{\sqrt{A_1}}{\sqrt{A_2}}$$

Where A is the catchment area in km<sup>2</sup>  
Q is the concerning maximum run-off in m<sup>3</sup>/sec.  
1 and 2 are the indices of the two respective areas

### III CALCULATING THE DIMENSIONS OF CHECK - DAMS

---

#### 1 CALCULATION ELEMENTS

As an example the following actual observations are used:

- In many cases the gradient of the slopes of a torrent is about 3:4 ( $37^\circ$ ).
- Check-dams not yet refilled are strained by full water pressure.
- Before refilling the check-dams were seldom dynamically strained by a mudflow, whereas after the refillment check-dam wings were exposed to mudflow, so that the danger of shearing existed.
- The stability of a check-dam can become critical as a result of the formation of a scour hole during high water. If the banks downstream from the check-dam slide, because of the deep scour hole, the resistance against an overturn or sliding becomes smaller.

In consideration of these facts and thoughts and with introduction of simplified assumptions the following calculations have been set up. For cases which do not correspond with these circumstances, the investigation has only a limited validity.

#### 1.1. Valley Shape, River Width, Longitudinal Gradient, Height of Check-Dam

According to the natural situation the valley shape has been assumed to have a bank slope of 3:4 ( $\alpha = 37^\circ$ ). For determination of the soil pressure of the valley flank at the side foundations of the check-dam it has been assumed that the valley flank consists of loose material. The angle of internal friction is equal to the angle of the slope ( $\alpha = 37^\circ$ ). Under this assumption the slopes are just in the labile equilibrium i.e. about to move. The base length B of the check-dams (= width of the river before the construction) has been varied from 1 m up to 20 m. Where it was important the longitudinal gradient has been taken as 20‰. The height of check-dams up to 12 m has been analyzed.

Geometry and nomenclature of the check-dams are shown in the Fig. 7.

#### 1.2. Forces Acting on the Check-Dam (Fig. 8)

The strain on the check-dams changes with the course of time. In Fig. 8 all the main strain cases are shown in a simplified way. In the first stage the check-dam is not yet refilled; the full hydrostatic waterpressure acts during high water (strain case 1).

Immediately after the gradual refilling (strain case 2) the reduced waterpressure (due to seepage) and the active soil pressure act on the upstream check-dam side.

In strain case 3 refilling is not gradual, but is caused by a mudflow which strains the dam by a bump.

In strain case 4 it is assumed that the new riverbed is completely aggraded and a

Front View

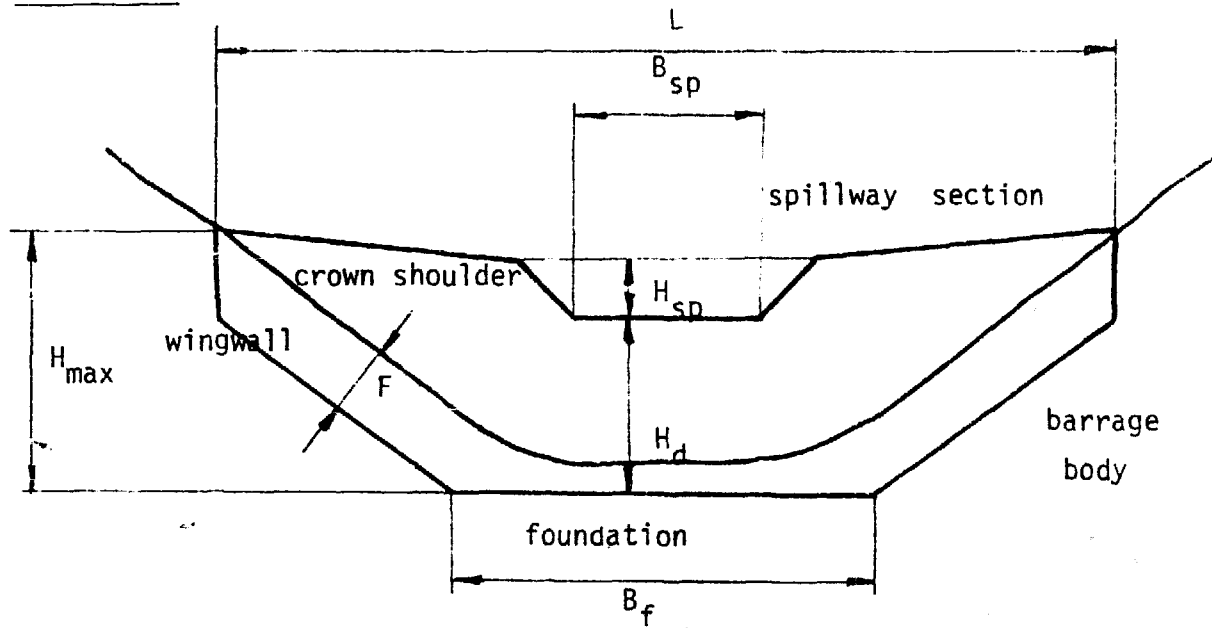

Plan

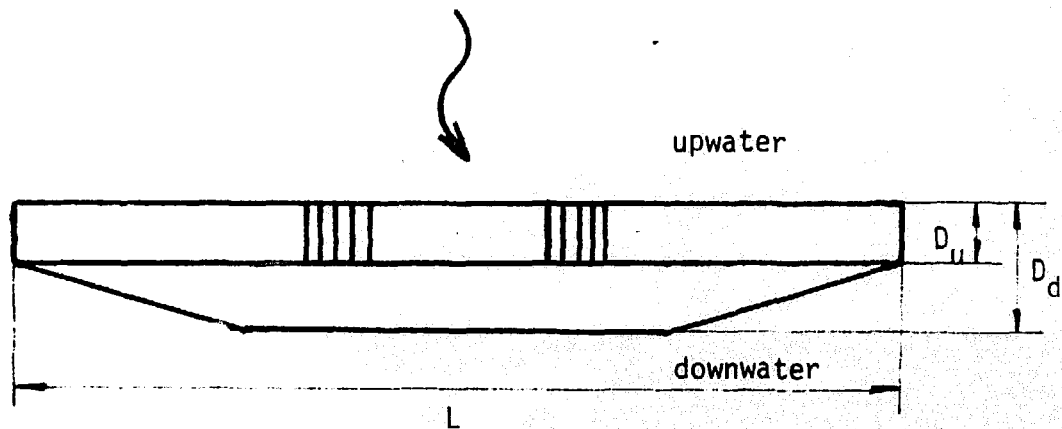

- $B_f$  = foundation length of the check dam
- $L$  = crown length
- $B_{sp}$  = breadth of spillway section
- $H_{sp}$  = height of spillway section
- $H_d$  = height of check dam
- $H_{max}$  = max check dam height in the side
- $D_u$  = width up (crown)
- $D_d$  = width down (foundation)
- $F$  = foundation depth, rectangular to the side
- $\alpha$  = inclination of the side of the check dam, respectively of the slope

Strain Case 1: Before Refillment

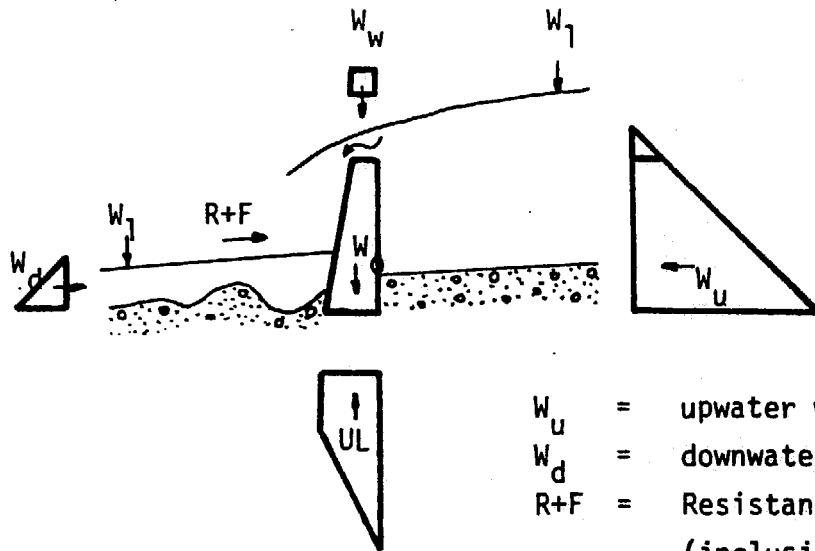

- $W_u$  = upwater waterpressure
- $W_d$  = downwater waterpressure
- $R+F$  = Resistance of sole and banks (inclusive friction)
- $W_o$  = own weight
- $W_w$  = water weight
- $UL$  = up lift

$W_u$ ,  $W_d$  and others are neglected for this calculation!

Strain Case 2: Immediately after the Refilling

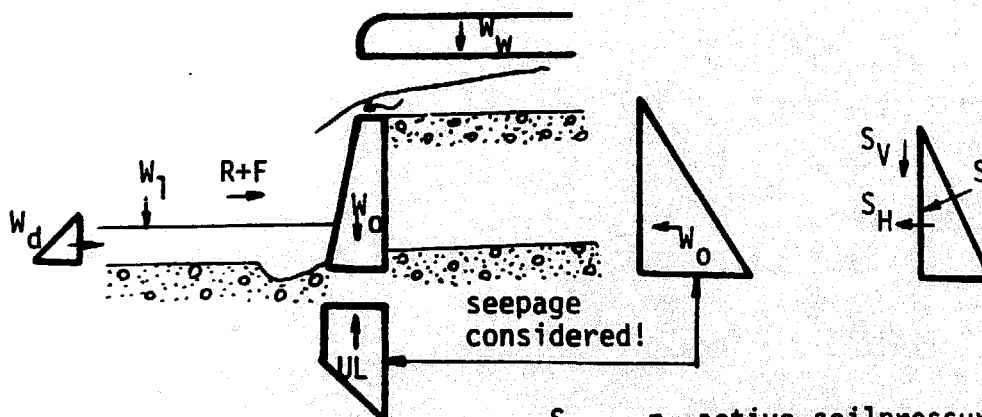

- $S$  = active soilpressure
- $S_h$  = horizontal soilpressure compo.
- $S_v$  = vertical soilpressure component
- $W'_u$  = upwater waterpressure with seepage

$W_d$ ,  $W_w$ ,  $UL$  and  $S_v$  are neglected for this calculation!



For the calculation of the waterpressure the following quantities are assumed:

- height  $H_{sp} + H_d$
- effect up to half the foundation depth

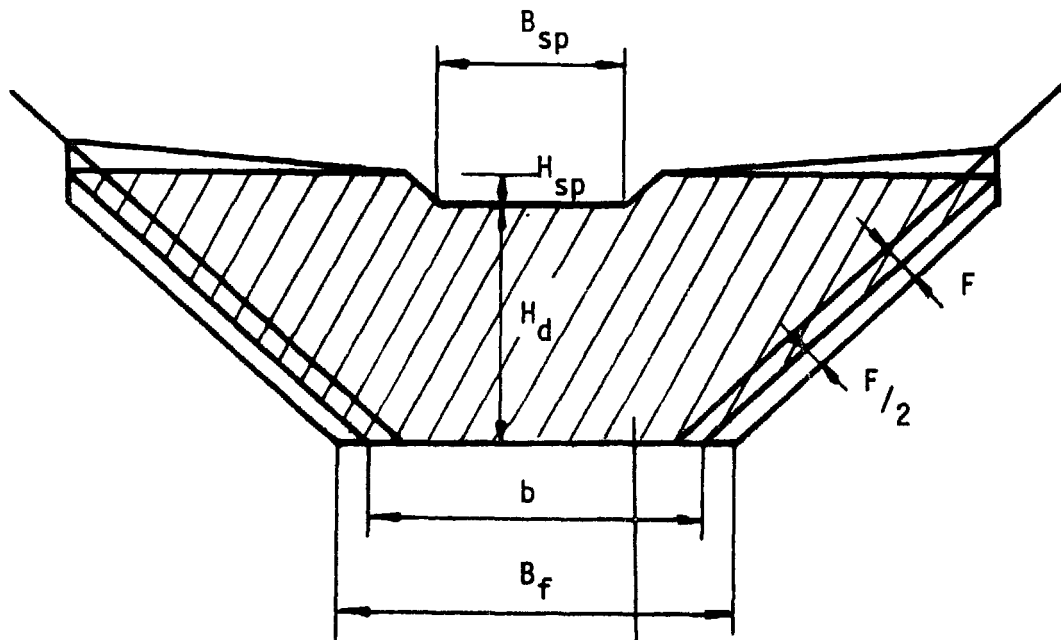

Area, on which the water-pressure is acting

Strain Diagramm

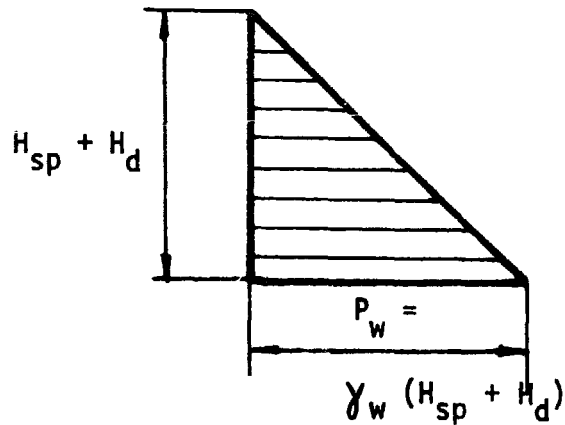

Strain Case 3: Bump through Mudflow

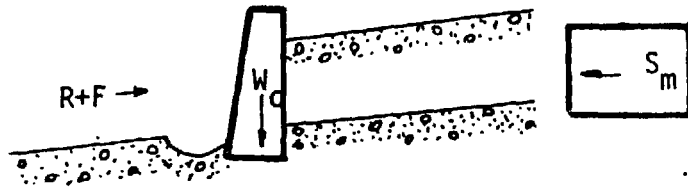

- $W_o$  = own weight
- $R+F$  = resistance of sole and banks
- $S_m$  = bump through mudflow

This case is seldom considered!

Strain Case 4: After the complete Aggradation of the new Riverbed, Sole and Banks intact

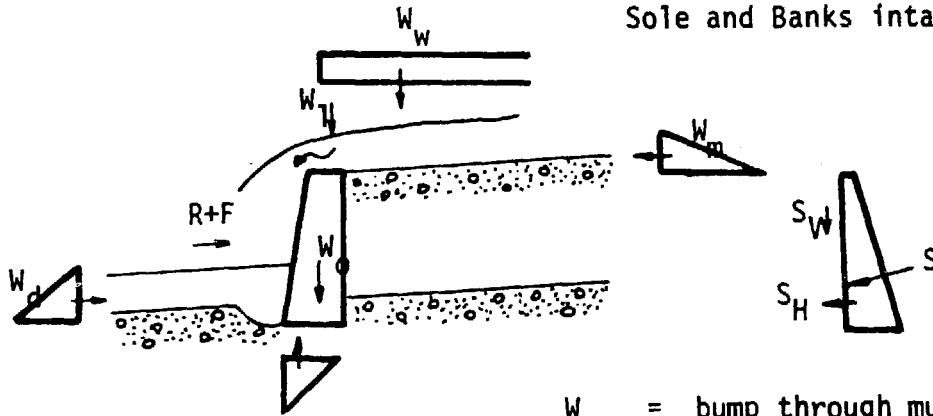

- $W_m$  = bump through mudflow on the shoulder wings

$W_d, W_w, UL$  and  $S_v$  are neglected for this calculation!

Strain Case 5: After the complete Aggradation of the new Riverbed, Sole and Banks slide away.

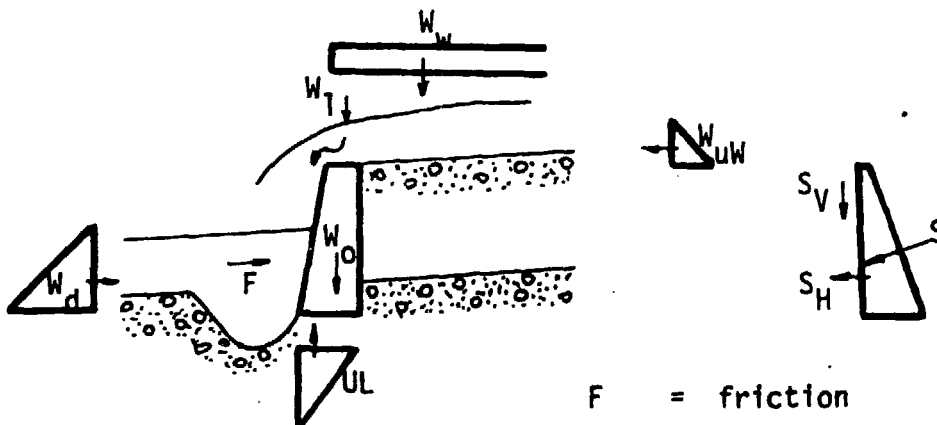

- $F$  = friction
- $W_{uW}$  = upwater waterpressure on wings

$W_d, W_w, UL$  and  $S_v$  are neglected for this calculation!

In strain case 5 (disaster case) it is assumed that the full waterpressure acts on the wings and the active soil pressure on the actual dam body. The banks downstream of the check-dam slide down owing to the deep scourhole, and therefore counterpressure derives only from friction.

#### 1.2.1. Water pressure from upstream

Immediately after the erection of the check-dam, but before its refilling, the full, hydrostatic waterpressure (during high water) acts on the upwater side of the check-dam, approximately up to half of the foundation F (Fig. 8, strain case 1; Fig. 9).

After the gradual refilling of the check-dam, but before their aggradation, the water pressure is reduced due to seepage-flow (Fig. 8, strain case 2). The detailed calculation gives always a value of approximately 70% of the hydrostatic waterpressure and this is independent of the permeability-coefficient. In addition, the normally arranged drain-holes (not specially necessary at gabion and loose-stone check-dams) reduce the waterpressure. The better the drainage through the drainholes and the better the aggradation of the riverbed, (the more impermeable the riverbed) the less is the waterpressure.

#### 1.2.2. Waterload

Normally the waterload on the spillway can be neglected.

#### 1.2.3. Waterpressure from downstream

The waterpressure from downstream can be neglected, because its amount is very small. And in addition it acts positively.

#### 1.2.4. Up-Lift

The up-lift can be read from the flow characteristics net. As a rule it can be neglected due the following reasons:

- the standing area of the check-dam is small
- the up-lift is small in relation to the weight of the check-dam
- the up-lift forces in the check-dam sides diminish towards the top

#### 1.2.5. Soil Pressure

As soon as the check-dam is refilled the soil pressure acts on the upstream check-dam side. The soil pressure can be calculated in different ways according to the different assumptions. These calculations and experience have shown that the soil pressure is 30% of the hydrostatic water pressure.

#### 1.2.6. Total Load of Water- and Soil-Pressure

In considering the seepage flow the following formula is valid:

$$\begin{aligned} \text{Water Pressure} + \text{Soil Pressure} &= \text{Hydrostatic Water Pressure} \\ 0.7 \left[ \frac{1}{2}(H_S + H_A)^2 \right] + 0.3 \left[ \frac{1}{2}(H_S + H_A)^2 \right] &= 1.0 \left[ \frac{1}{2}(H_S + H_A)^2 \right] \end{aligned}$$

Check-dams consequently are to be dimensioned to the full hydrostatic water pressure for the phase before refilling and before complete aggradation of the new riverbed. This is equal to the check-dam which is strained by full water pressure due to lack of refilling (Fig. 8, strain case 1).

The horizontal load at the refilled dam after complete aggradation of the new riverbed (Fig. 8, strain cases 4 and 5) gives a smaller amount. The water pressure acts only on the wings and the refilling is calculated with the wet weight

$\gamma = 2 \text{ t/m}^3$ . Higher values than the full waterpressure are reached when the dam is completely settled and no seepage exists. For this extreme situation the hydrostatic waterpressure and the soilpressure are added together, which results in a 1.3 fold hydrostatic waterpressure.

To design all check-dams according to these unfavorable strains is not justified because there are other assumptions which act in the other direction.

Consequently the important decision follows that as a rule the check-dam has to be designed on the basis of full hydrostatic waterpressure, if mudflows are neglected.

(With this finding, the calculation is made with the full hydrostatic waterpressure. The surcharge according to Coulomb's Wedge Theory is already considered!)

### 1.2.7. Mudflow (Fig. 8, strain case 3)

During storms mudflows (a nearly over saturated slurry, possibly mixed with big stones, root stocks and trees) can cause forces which are extremely difficult to estimate.

In Switzerland the calculation of two check-dams broken by a mudflow showed, that the existing dynamic mudflow strain is about 7 to 10 times the value of the static waterpressure. ( $\gamma_{\text{mudflow}} = 7-10 \text{ t/m}^3$ )

To strengthen the resistance of check-dams, they can be refilled artificially immediately after construction. For the check-dam body there is no more danger from the mudflow after the refilling. Only the shoulders are in danger of being sheared off by a mudflow. Therefore the design of the spillway and the crown needs a corresponding shape (see 4.6.).

## 2 STATIC AND SOILMECHANICAL CALCULATIONS

### 2.1. Relevant Strains

For the design of torrent control check-dams the following strains are relevant according to chapter 1.1.

#### 2.1.1. Normal Case (Fig. 8, strain cases 1 and 2)

On the check-dam the following forces act

- horizontally - from upstream
  - the full hydrostatic waterpressure
  - from downstream
  - the resistance of the sole and banks  
(= soil resistance and friction)
- vertically - the check-dam's own weight

#### 2.1.2 Mudflow strain (Fig. 8, strain case 3)

The check-dam must resist the following strains:

- horizontally - from upstream
  - the 3 fold waterpressure on the shoulder
  - the active soil pressure on the body ( $2\text{t/m}^3$ )  
(acting only on  $h$  [fall height], and not on  $h_F$   
[height of foundation])
  - from downstream
  - the total resistance of the sole and banks

vertically - the own weight of the check-dam

### 2.1.3. Disaster Case (Fig. 8, strain case 5)

The check-dam must resist the following strains:

horizontally - from upstream  
- the plain waterpressure on the shoulder  
- the active soil pressure on the body ( $\gamma=2t/m^3$ )  
- from downstream  
- the friction between the banks and the dam  
(without the soil resistance of the banks)

vertically - check-dam's own weight

Remarks: Because the check-dams are calculated as gravity check-dams the strains of one strip (take a metre unit) must find their counterstrains in the same strip. Therefore at a strip at the spillway section, there is no soil resistance because of the scourhole. Friction is the only counterstrain.

## 2.2. External Statics

### 2.2.1. Overturn

The overturn security is defined by the quotient from the stabilizing and overturning moments in relation of the lower edge of the downstream structure. The single moments have to be estimated based on the relevant strains according to chapter 2.1. The security factor must be at least. 1.2.

$$\eta_o = \frac{M_{\text{stabilizing}}}{M_{\text{overturning}}} \rightarrow 1.2$$

Forces creating overturning moments are:

- the upstream water pressure
- the soil pressure of the fill material
- eventually the mudflow strain
- eventually the up-lift

Forces creating stabilizing moments are:

- the check-dam's own weight
- the total resistance of the sole and banks against the check-dam  
(soil resistance and friction) In the disaster case this is only friction.

### 2.2.2. Sliding

The security against sliding  $\eta_s$  is given by the quotient between the resisting and the driving forces. This security factor must be at least 1.2.

$$\eta_s = \frac{F_{\text{resisting}}}{F_{\text{driving}}} \rightarrow 1.2$$

Driving forces are:

- the upstream water pressure
- the soil pressure of the fill material

- eventually the strains of a mudflow
- eventually the up-lift

Resisting forces are:

- the total resistance of the banks and the sole against the check-dam (soil resistance and friction). In the disaster case this is friction only.

Check-dams can be made secure from sliding by strengthening with deep foundations in the sole and in the banks.

Table 7 Co-Efficients of Friction

Material	$\mu$
Masonry on sand	0.40
on gravel	0.60
on masonry	0.70
on rock	0.75

The co-efficient of friction is the tangent of the angle of internal friction.

### 2.2.3. Bearing Pressure

The safety for the bearing pressure is defined as the quotient  $\sigma_p$  between the admissible and the actual pressure. It must be at least 1.2.

The real bearing pressure is the weight divided by the standing area.

$$p_{\text{actual}} = \frac{W_0}{\text{area}}$$

$$\sigma_p = \frac{P_{\text{ad}}}{P_{\text{ac}}} \gg 1.2$$

Table 8 Admissible Bearing Pressure

Kind of soil	Pressure in t/m <sup>2</sup>
Clay	5 - 20
Sand	20 - 40
Gravel and Boulder	40 - 60
Hard Rock	200 - 300

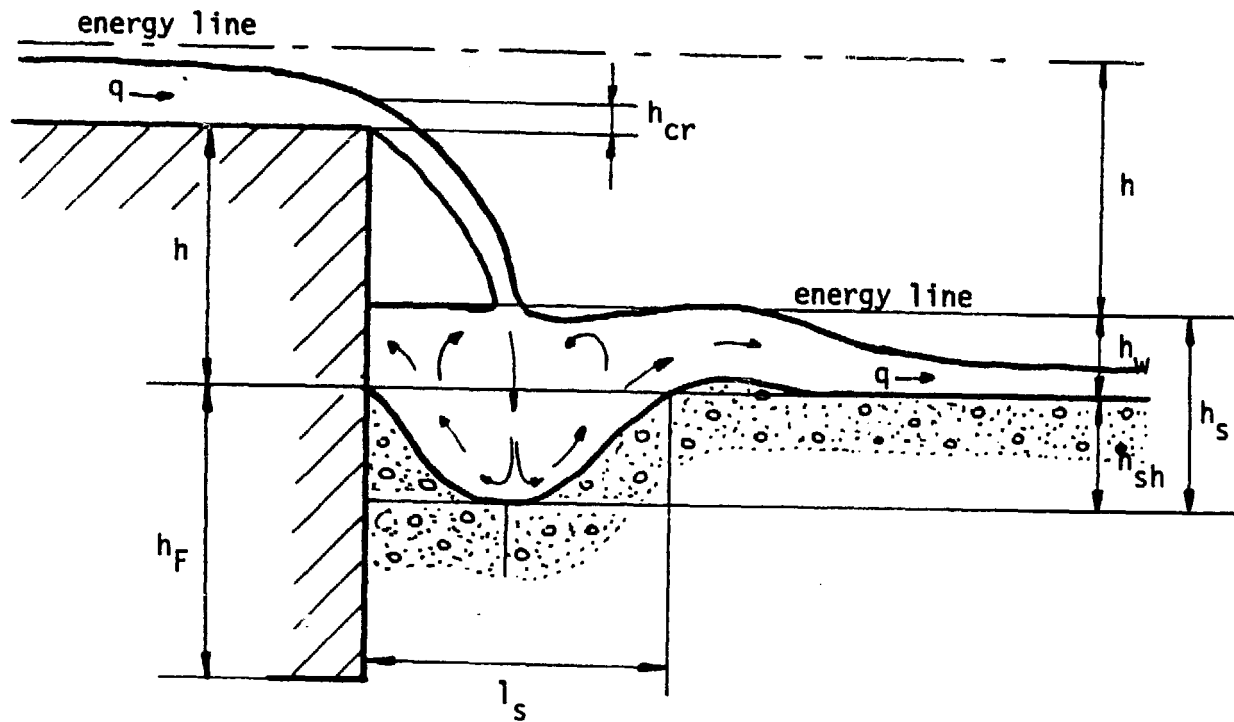

Units: m, sec

$B_{sp}$	breadth of spillway
$H_{sp}$	height of spillway
$H$	Height of energy line
$h_{cr}$	critical height
$Q$	run-off
$q$	specific run-off
$h$	fall height of check dam
$h_w$	water cushion height
$h_s$	scour water depth
$h_{sh}$	scourhole depth
$l_s$	scourhole length
$h_F$	height of foundation
$d_{95}$	grain diameter which divides bed material in a way that 95 percent is smaller than $d_{95}$
$b_{sh}$	breadth of scourhole
$t_F$	foundation thickness

### 3.1. Spillway Section

$$q = \frac{Q}{B}$$

$$h_{cr} = \sqrt[3]{\frac{q^2}{g}}$$

$$H = \frac{3}{2} h_{cr}$$

### 3.2. Scourhole

For the foundation depth it is important to know the scour-depth, for the next close check-dam the scour-length (also called stilling basin) and for the apron the length between the wall and the deepest scourhole point.

#### 3.2.1. Scour-Water-Depth

$$h_s = 0.79 \frac{h^{0.343} \cdot q^{0.686}}{d_{95}^{0.372}}$$

#### 3.2.2. Scour-Length

$$L_s = 0.73 \frac{h^{0.457} \cdot q^{0.914}}{d_{95}^{0.828}}$$

#### 3.2.3. Breadth of Scourhole

$$b_{sh} = 1.5 \cdot B_{sp}$$

### 3.3. Examples

$Q = 4.5 \text{ m}^3/\text{s}$	$B_{sp} = 3 \text{ m}$	
$q = \frac{4.5}{3} = 1.5 \text{ m}^3/\text{s}\cdot\text{m}$	$d_{95} = 0.30 \text{ m}$	
$h_{cr} = \sqrt[3]{\frac{q^2}{g}} = \sqrt[3]{\frac{1.5^2}{9.81}} = 0.61 \text{ m}$		critical height
$H = h_w = \frac{3}{2} \cdot h_{cr} = 0.92 \text{ m}$		
$h_s = 2.38 \text{ m}$		scour water depth
$h_{sh} = h_s - h_w = 2.38 - 0.92 = 1.46 \text{ m}$		scour depth
$L_s = 4.73 \text{ m}$		scour length
$b_{sh} = 4.5 \text{ m}$		scour breadth



### 3.4. Remarks

- These scourhole-formulas are based on a 4-hour peak run-off, acting on the scourhole. If the peak run-off lasts longer the value must be increased by 10 %.
- Check especially at gravity check-dams, that the scour depth does not go deeper than the foundation depth!

## 4 RECOMMENDATIONS FOR TECHNICAL IMPLEMENTATION

For the engineer involved with torrent control work it is his most important tasks are to select suitable construction material, to place them professionally and to join each other. To solve this problem it is necessary first of all, to recognize the basic casualties which are explained by the sedimentation source, the acting soil movements and the water. Secondly the right judgement about the effect of the single construction material is necessary. Both require the right eye, skilled by experience and observation, in addition to the theoretical know-how.

### CROSS CONSTRUCTIONS

Among all constructions determined by checking torrents, the cross constructions are the most significant ones.

They are defined as constructions across or rectangular to the rill which lift the sole or prevent their further cutting. The larger ones of such constructions are called sediment retaining dams, the smaller ones check-dams, step dams, ground weirs or sole weirs. It is difficult to distinguish between them.

The cross constructions are made in dry, wet or mixed masonry, in concrete, in RCC, in gabions, in timber or in a combination of these.

#### 4.1. The Purpose of Cross Constructions

The purpose of cross constructions is to retain the already moving sediment or to prevent further sedimentation. For the first purpose they are called sediment retaining dams, the latter ones, check-dams.

The cross constructions have the following tasks:

- to reduce the gradient of the torrent and therefore to diminish its energy
- to prevent on-going erosion
- to lift the bed, and with it to safeguard the foot of the adjacent banks and slopes, and to widen the riverbed
- to guide with spillway sections the course of the torrent, so as to protect dangerous sites
- to prevent scouring at other structures or to protect them

#### 4.2. Selection of the Construction Site

For retaining structures it is possible to select the best site for their erection, maintenance and effect, whereas for check-dams the site has to be taken where the torrent has to be improved or where the sole has to be lifted. Only small changes are possible with the variation of the check-dam heights and the distribution of the check-dams within the gully.

Within these limits, sites are preferred where a safe foundation is possible in the sole and in the banks. However a systematic construction of a series of

check-dams is not possible if only such suitable sites were selected. In wide gullies the width of the check-dams can be reduced with the construction of guide walls.

In straight torrents the check-dams are placed at right angles to the rill. In bent torrents the spillway section is placed rectangular to the sight to the next lower section (see Fig. 11).

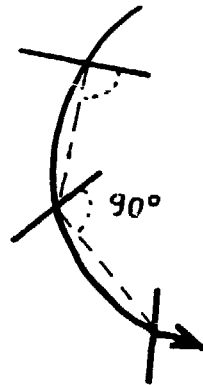

Fig. 11 Placement of Check Dams in a bent Torrent

#### 4.3. Determination of the Check-Dam Heights

To serve its purpose perfectly and for a long time the retaining structures need a big retaining capacity and therefore a big height. The retaining capacity increases with height. It is a matter of calculation to evaluate which construction height and its estimated costs gives the optimum design. For retaining structures, normally bottlenecks with steep banks are chosen where it is more economical to construct high structures.

With check-dams, the decision whether to construct a few high structures or more low structures must be taken according the circumstances

Often the height is limited by the cross section of the gully and the construction material. Experience has shown that gravity check-dams as made in Nepal may have maximum height of

- 4 to 6 m for dry masonry
- 6 to 8 m for gabion
- 8 m for cement masonry

The costs of gravity structures increase quickly with heighth!

The height of the check dams must be arranged according to the local situation and the purpose of the structures. Where only a consolidation of the sole, or prevention of further erosion is involved, low ground weirs (step dams) are sufficient. But where a higher sole lift is needed, higher check dams are necessary.

The amount of the sole lift depends on the adjacent slopes. The sole should be lifted up to such a level that the slopes get their natural angle of repose, after refilling of the structures. Remember that the angle of the slope is normally steeper than in the cross section of the gully!

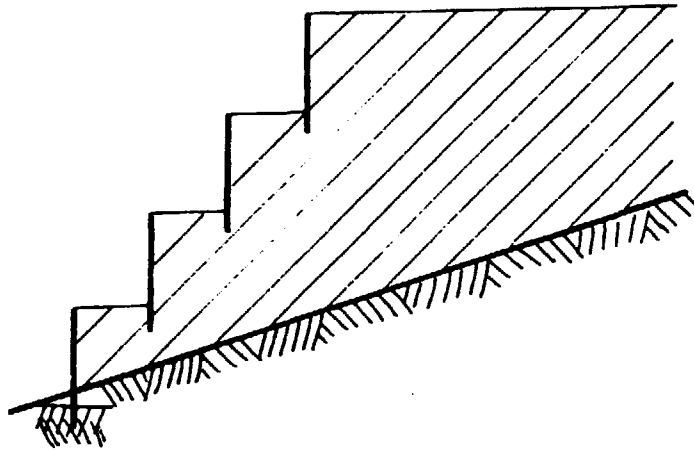

Fig. 12 A High Sole Lift with several Check Dams

In deeply cut gullies it is often impossible to lift the sole high enough with only one structure. So two or more structures built one behind the other are necessary (Fig. 12). In such cases the separate structures have to be situated as closely as possible to each other. The distance between structures has to be calculated so that the water does not fall on to the lower structure! (See scour length 3.2.2.). With such structures the upper one may be constructed on the fill from the lower one (this is normally possible after one monsoon). Experience has shown that it is possible to build directly on the fill without consideration, if this material is composed of boulder, stones and sand. These are the material of mudflow and bedload. Such a material has an insignificant or no settlement.

It is difficult to estimate the required sole lift at places where the adjacent slopes are oversaturated since sliding and a lateral pressure act there. This oversaturation can be controlled with drainage. The structures must be situated in such a way that no lateral pressures act on it. Otherwise they must be designed accordingly.

#### 4.4. The Form of the Cross Constructions

The form of the cross constructions depends on the construction material and on the kind of construction. Normally a form curved upstream gives the best result for bow dams and gravity dams (Fig. 13). Curved check-dams distinguish themselves by a big resistance against pressure and bump. In contrast dams which have a longer span or are not based in rocky banks, cannot be calculated as a bow construction but as a gravity construction. They are also constructed in a bow, if possible! So that they are much more resistant than straight ones (Fig. 13 alt b)

If the slopes rise only gradually at the side foundation the wings are designed as tangents.

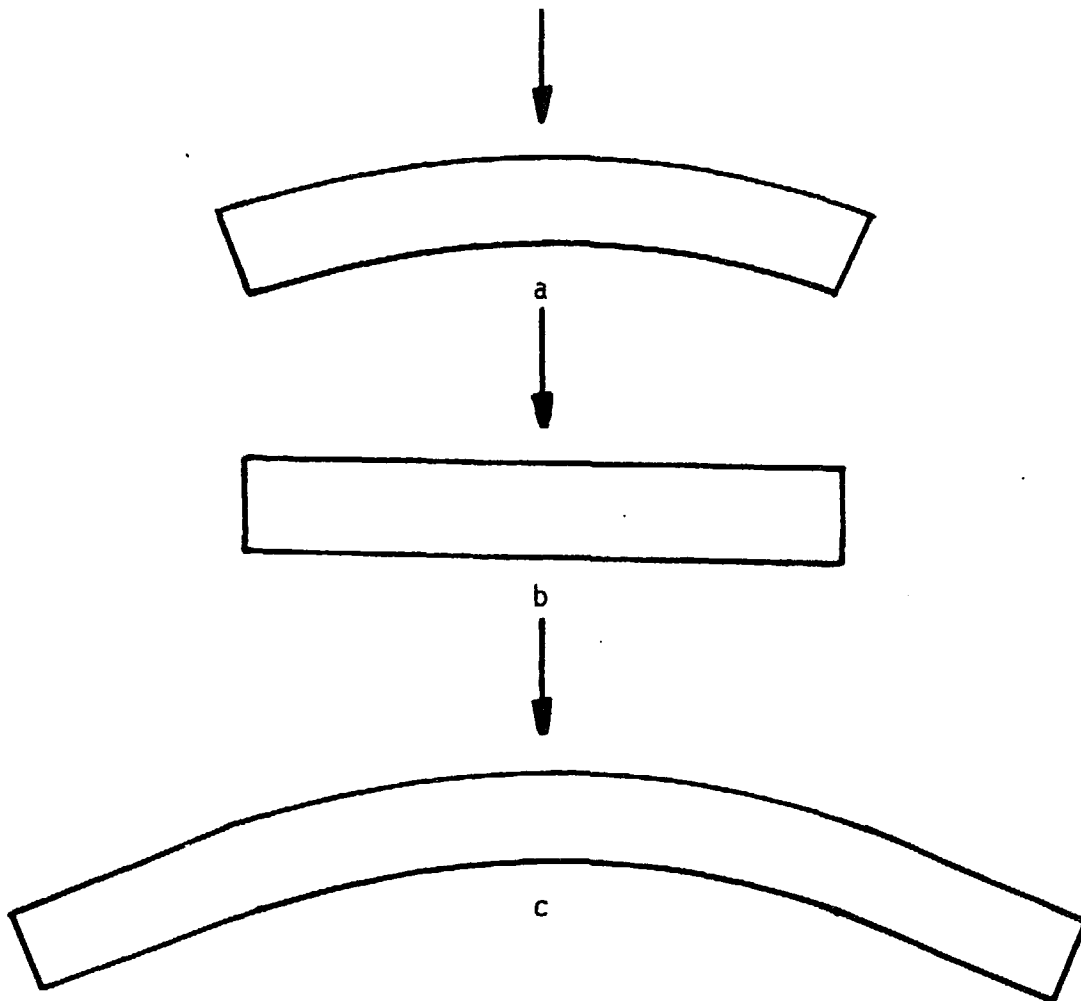

Fig. 13 Basic Forms of Cross Structures

A straight structure can more easily resist a big lateral pressure than a bowed one. In this case it is more advisable to design a straight form. Small structures, groundweirs etc. are designed straight, too!

#### 4.5. Cross Section

The cross constructions must have such a cross section that they can resist the water pressure, and after filling, the pressure of the fill material. The cross construction transfers the soil and water pressures over the bow on the abutment or in the gravity check-dam on the subsoil. In both cases the following conditions for stability must be fulfilled (see also 2.2.):

- the pressure line must be within the core
- the construction must be safe against overturning and sliding
- the maximum pressure may not exceed the bearing capacity of the construction material and the resistance of the subsoil.

The hydraulic elements are basic to the design of the cross section.

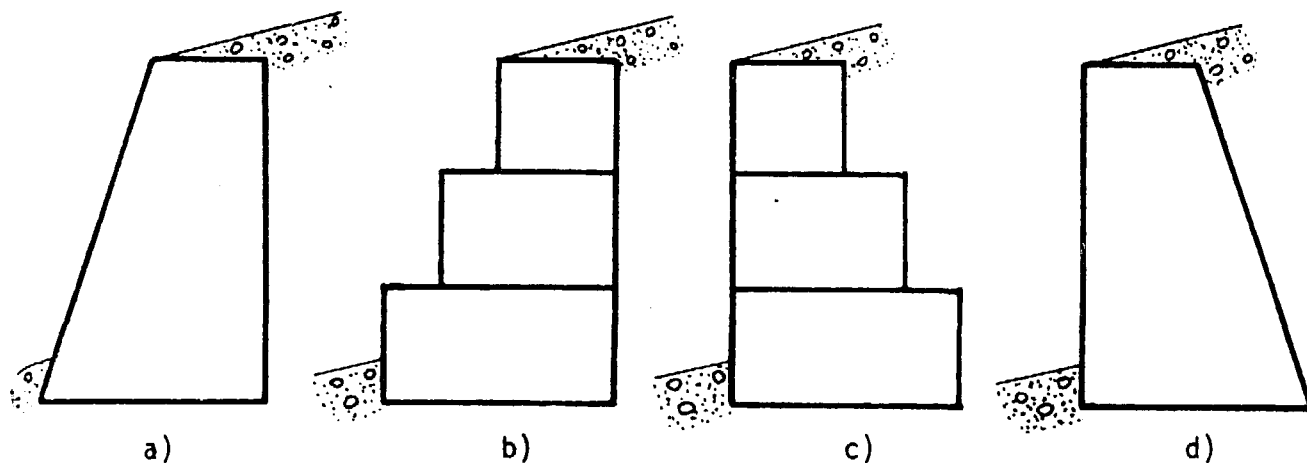

Fig. 14 Basic Forms of Cross Sections

Fig. 14 shows the main basic forms of cross sections. Type b) and c) are constructed in gabions, type a) and d) in masonry. Figs. a) and b) show the downstream inclined wall and vertical upstream wall. In these forms of cross sections the water with the bedload falls over the inclined or terraced wall and damages the wall. Especially at the terraced wall the edges of the gabions are exposed to the falling material. Even if these forms are very suitable for static forces, they must be avoided. Check-dams with an inclined wall may be constructed if the surface of the inclined wall is done in huge well shaped stones. Only such huge stones do not suffer from falling material.

The form shown in Figs. 14 c) and d) is suitable for the bedload fall. Even if these shapes are not quite favourable from a statics point of view, experience has proved their durability.

Figs. 15 a) and b) show gabion check-dams in cross section. In a) the full volume is made in gabion, whereas in b) only the front wall is made in gabion. Both structures have the same effect but b) is less expensive. The rest of the dam body is made of dry masonry. For this masonry stones of about  $\phi$  20 cm are recommended. It is advisable to put a few gabions across the front wall to anchor the wall in the dry masonry. Fig. 15 c) shows a check-dam with an inclined gabion front wall. The hind part is filled with dry masonry. The angle of the inclination is the same as the angle of the pressure line. This type is very perfect from the statics point of view, but it may be used only in rivers without bedload. This kind of construction needs some skill. The gabions are placed and filled at an angle which needs some know-how on the side of the contractor and the labourers.

Fig. 15 d) shows an inclined dry masonry wall. In this type only the front wall is made in big boulders (50-200 cm), the rest is made in small stone dry masonry.

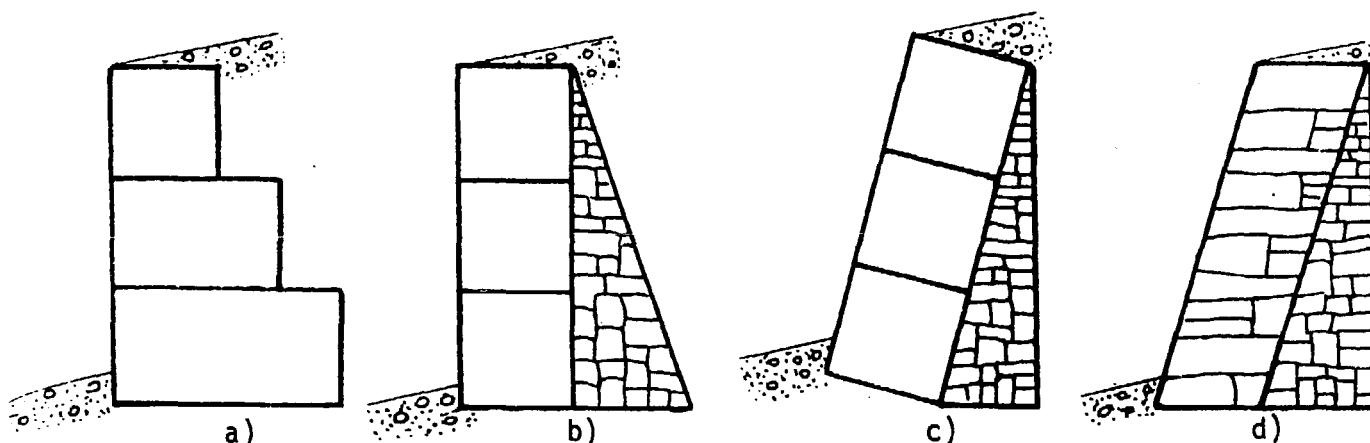

Fig. 15 Variation of Cross Section Form

#### 4.6. Spillway Section

The spillway section is formed by lifting the dam wings to guide the flowing water in a defined way and to fix the place where the water should fall. The spillway section must be designed big enough to lead off the high water including the bedload. To design the spillway section is difficult because there are no accurate formulas to estimate high water, bedload, their velocity and a possible mudflow. For these reasons it is necessary to design a secure height (0.3-1.0 m) and an inclined crown shoulder.

The breadth of the spillway section varies according to the breadth of the riverbed, and shall be designed in such a way that a stilling basin is formed without endangering the banks. The symmetrical spillway sections have different forms, such as a circle segment, a trapezium, a trapezium with rounded edges, a rectangle or a triangle (Fig. 16).

The circle segment with a big centre angle holds the water together best, and does not favour the deposition of stones in the spillway section. This form has the disadvantage, that not only the power of the water is concentrated at the lowest part but also the bedload, which results in a big abrasion. Spillway sections with a level sole permit the water to widen, the water stream is weakened, and the scouring on the apron or in the stilling basin is reduced. Rectangular forms should be avoided unless guidewalls lead the water and bedload to the spillway section. Otherwise the crown shoulders are fully exposed to a mudflow! The triangle form should be avoided, too, because water is concentrated in one place.

The form of the spillway section shall be selected according to the local situation and according to the construction material used.

The sole of the spillway section is extremely exposed to the abrasive forces of the water and especially of the bedload. These forces must not be neglected, otherwise the sole of the spillway section is broken after only a few monsoons.

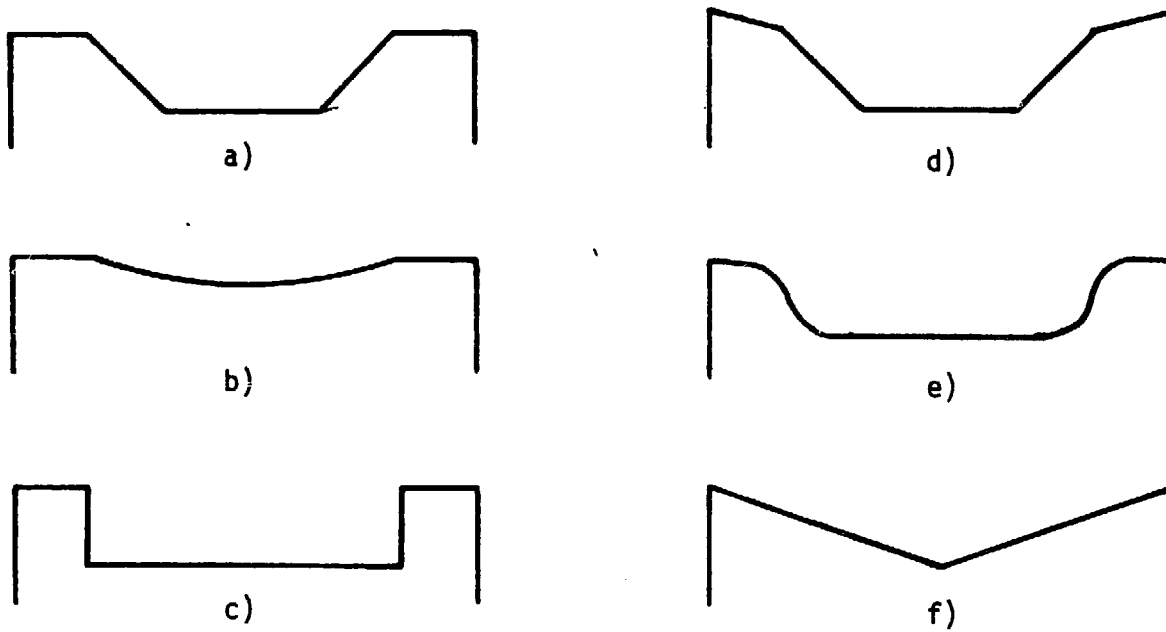

Fig. 16 Symmetrical Spillway Sections

For dry masonry only big, heavy, well shaped and very well fitted stone-cubes may be used for this sole. The required size can be calculated according to the formula in appendix 1.

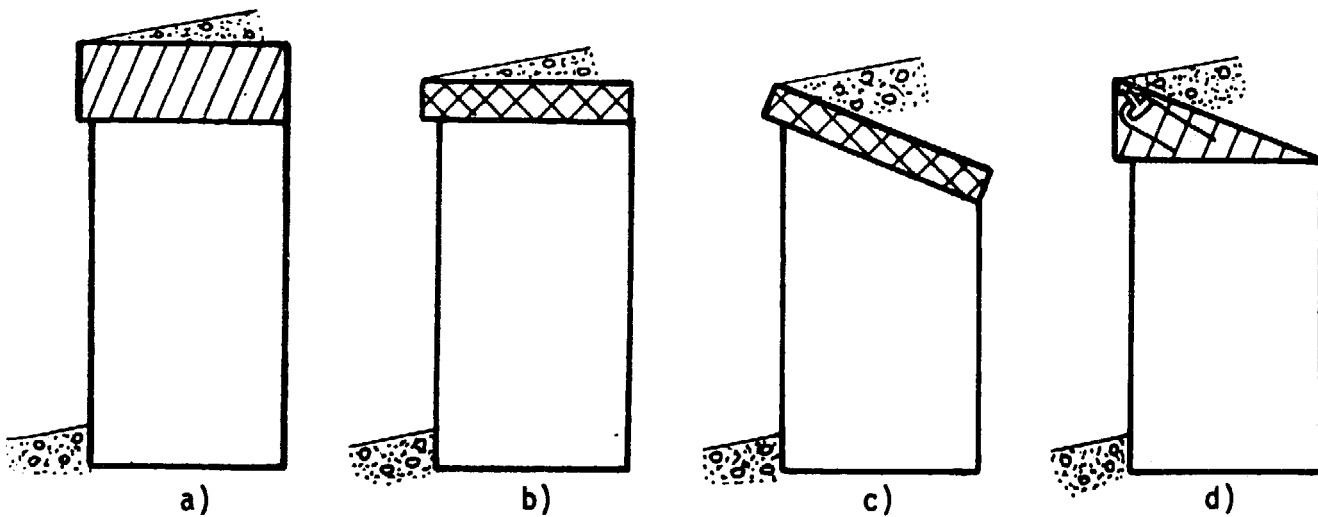

Fig. 17 Spillway Sole Improvements

A few spillway sole improvements are shown in Fig. 17 and are discussed below.

- a) The sole is protected with a cement masonry layer (about 50 cm). This construction can be used for dry masonry - and for gabion check-dams. In gabion structures the cover of the uppermost gabion is placed in the middle of the layer. The mortar must be made out of a 1:3 cement-sand mixture.
- b) The sole is protected with big gneiss or granite plates (or flat rocks). If necessary the plates are anchored in the body with cement or with iron bars.
- c) This is the same solution as b), but laid at an incline. This has the advantage that the fill protects and puts pressure on the plates which gives them a better settlement.
- d) The sole is made in concrete or cement masonry with an inclined surface. The most endangered edge is made of a rail. This rail is embedded in concrete and anchored with iron bars. The embedding must be made of best quality concrete.

It is recommended to design a nose (about 10 cm long) together with the sole improvement to protect the front wall against falling stones.

#### 4.7. Drainholes and Culverts

Behind all impermeable structures a big water pressure can build up. So drainholes and culverts are needed to drain the fill and reduce back pressure. Drainholes and culverts are only necessary in cement masonry - concrete or R.C.C. - structures. The porosity of dry masonry and gabion check-dams is sufficient to drain the fill.

#### 4.8. Scouring Problem (for formulas see 3.2.)

Scouring is the biggest enemy of check-dams. It is caused by the energy of the falling water and bedload. The energy is destroyed in the scourhole or on the apron. Even firm rock can not resist the scouring forces caused by water falling from big heights. If the check-dams are not based on rock, big scourholes will be created. The closer the distance between the frontwall and the waterstream, the more the frontwall is endangered. This distance can be increased with noses or with consoles (see Fig. 17). Especially in gravity structures, where the body is based on the foundation, this foundation is in danger of collapsing. So the frontwall must be constructed in such a way that it can resist the scouring forces. In addition it is important to keep the scouring always on the same level. This level can be checked through the height of the next lower check-dam or through an apron. Because the stones of an apron get destroyed after a few years, the apron must be renewed periodically. With a small ground weir a stilling basin can be made, where the energy of the falling water is destroyed in the water cushion.

#### 4.9. Foundation

Especially with gravity check-dams the structure must be well based in the sole and in the banks. According to the needs of the design the foundation depth for the sole and for the banks is given. But the foundation must reach firm rock or gravel and should not be based on soil or weathered rock. With the excavation all dead rock, soil and nonhomogeneous material (like timber remains) must be removed, even if this is not foreseen at the time of estimation (this is the reason for an overhead).



Never base structures on a slanting excavation hole. The sole for the foundation must be level. All obstacles must be taken out and big stones or rock must be removed. Even the foundation in the banks must be level. Build terraces with a minimum length of 30 cm.

Take a 1.0 m foundation in the sole and 0.5 m in the banks as a rule of thumb. The sole foundation may be less, if the foundations is controlled by the next lower check-dam (at a sole lift) see Fig. 18.

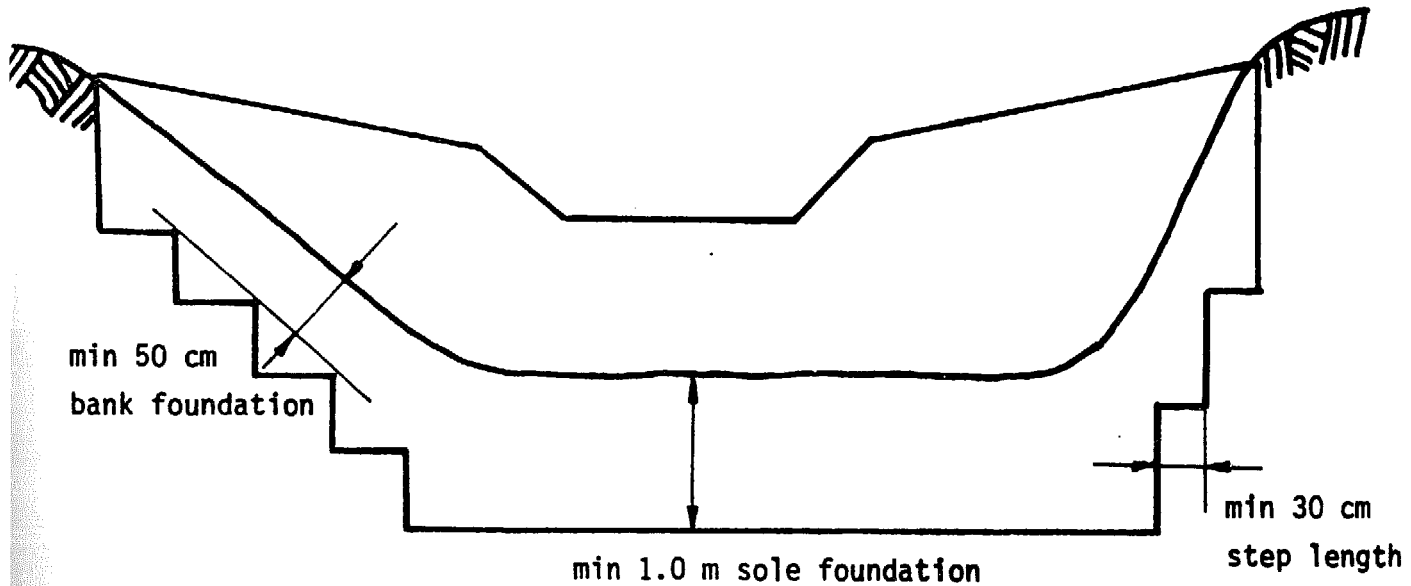

Fig. 18

Foundation Depths

Prevent water standing in the foundation. Drain the water with a French-Drain. This is a drain of 20x20 cm filled with stones ( $\phi$  10 cm).

The foundation must be deeper than the scour hole. Take a secure height of 50 cm for the foundation (deeper than the deepest point of the scour hole)!

## 5 GENERAL SUGGESTIONS FOR CONSTRUCTION

To obtain a satisfactory result the following must be observed in all constructions:

- Construct check-dams at the same time as the treatment of the upper catchment and the adjacent slopes (plantation, afforestation, diversion channel, retaining walls, trimming steep slopes), or even better, start these treatments before the construction starts!
- Select the appropriate construction site and design properly to get the best result!

- Choose the best construction materials available nearby!
- For loose-stone check-dams make good dry masonry structures with big, well shaped, hard stones. The size of the stones used for construction must be bigger than the stones transported in the gully!
- Use the biggest and hardest stones for the spillway section and the foundations!
- For gabion check-dams the stone-size must be bigger than the mesh. Also here, only dry masonry may be used with well shaped and hard stones. The wire must be well galvanised. The gabions must be well and firmly tied first to close the gabion-box itself and second to fix the gabion with its surroundings!
- Do not expose gabions to flowing or falling water (especially if there is a bedload)!
- The foundation must be firmly based in the subsoil and in the banks. The foundation-depth depends on the quality of the soil, and the rock!
- The spillway section must take the peak run-off flow!
- Prevent water by-passing check-dams with guidewalls!
- Plan a life-span for the structure of 30 to 50 years. Expenditure on the construction can be justified economically only by such a long period!
- Maintenance is as important as the construction itself. Remember the proverb: "Don't start construction, if there is no will to maintain!"

## IV CONSTRUCTION MATERIALS

---

(The following text is taken from the "Indian Practical Civil Engineer" and from the "Manual of Reforestation and Erosion Control for the Philippines", see Bibliography nos. 3 and 6)

The only construction materials which may be used are those which are economical, durable, sufficient for the requirements and locally available, or which can be easily transported to the construction site. The construction design has to depend on the material available.

### 1 MASONRY

Masonry in a broad sense is employed for retaining walls and for the construction of weirs and check-dams. One can use natural stones, bricks or hollow blocks. Since the latter two are quite expensive, natural stones are most commonly used for masonry work in erosion control.

#### 1.1. Requirements for Construction Stones

The chief requirements of a construction stone are strength, density and durability combined with reasonable facility for working. A good construction stone should be hard, tough, compact grained and uniform in texture and colour. Stones with uniform colour are generally found to be durable. Red and brown shades and mottled colour indicate the presence of injurious materials. Generally speaking the heaviest and compact grained stones are the strongest and most durable; a construction stone should have a crushing strength of at least  $110 \text{ kg/cm}^2$ . A crystalline stone is superior to a non crystalline one and the firmer the crystalline texture, the stronger it is. Igneous and metamorphic rocks are generally heavier and more durable than sedimentary rocks. A stone absorbing less water is stronger and more durable as it will have less action of rain water. A good building stone should be free from decay, flaws, veins, cracks and sand-holes.

The surface of a freshly broken stone should be bright, clean and sharp and should show uniformity of texture without loose grains and be free from any dull chalky or earthy appearance.

Stones should be properly seasoned by exposure to the air before they are put in a structure, as stones increase in durability after quarrying if well seasoned, especially limestones, sandstones and laterites. Stones newly quarried contain quarry-sap and can more easily be worked in this condition. The hard stones such as granite, are most durable with a rock-face finish, while the softer and more absorbent stones are usually most durable with a sawn or rubbed surface. The estimated life of granite, gneiss and good sandstone buildings is considered to be well over 200 years, while limestones and weaker types of sandstones hardly last for 50 years. Harder varieties of crystalline stones having a dense texture re-

ceive a good polish. Granites, marbles, slates and compact varieties of limestones can be polished well.

The strenght of a stone is greatly reduced under following conditions:

- a) Alternate wetting and drying, especially sand- and limestones. Stones in wet condition show a lower crushing strenght than when they are dry; strength may be reduced by 30 to 40 per cent.
- b) Impact and intermittent loads as in the case of machine rooms and piers or abutments of bridges.
- c) Fire brings about rapid destruction of stones by disintegration.



Photo No 4  
Nicely shaped stone-cubes at a dry masonry  
check-dam in Tansen

## 1.2. Providing Construction Stones

The stones lying around are normally not sufficient for the requirements, so stones must be quarried.

Quarrying of stone for small jobs is generally done by hand tools alone such as, crowbars and wedges. In large quarrying operations in hard rocks, rock drills are used.

There are natural joints and fissures in rocks and advantage is taken of these joints, where existing, in separating one block from the other. Fissures, cracks, planes of cleavage and bedding planes of stratification are all weak points in a rock. Where natural fissures or joints do not exist, artificial fissures can be made by drilling a line of holes ( in rows), about 1 cm to 5 cm in diameter 10 cm to 15 cm in apart and about 15 cm to 20 cm deep with the aid of a chisel and hammer. In quarrying, holes are jumped or drilled along the desired line of cleavage. Two half round pieces of steel with a conical wedge between them are placed into each hole (these devices are also called "feathers" and "plugs"). If all the wedges are driven along together in succession with a hammer the rock will crack along the face of the holes. Instead of steel wedges, round plugs of dry hardwood are sometimes driven in and kept soaked with water. The swelling of the wood will split the rock. Lighting and maintaining a fire on the surface of a rock causes the upper layer of the rock to expand and separate from the lower mass.



Photo No 5  
Dry Masonry check-dam in Khare Khola.  
Big stones has been used for.

### 1.3. Preparation of Construction Stones

The stones used for dry masonry must be of large size and a good shape. The bigger the stones and boulders the better for the stability of the structure. A good approximation for the required stone size is given in appendix 1. The specification required for the stone shape must be one of the following, according to the structures' need:

#### a) Square Rubble, brought up to courses:

Beds and joints: To be one line dressed. No face joint shall be thicker than 1 cm. The face stone shall be laid alternate headers and stretchers.

Height of course: 15 cm to 25 cm. No course to be of greater height than any course below.

Bond or through stones: 1.5 m apart in the clear in every course and to be staggered, and as for ashlar masonry below.

#### b) Block in Course:

The stone shall be hammer or chisel-dressed on all beds and joints so as to make rectangular shapes (two line dressed). Joints shall be dressed at right angles to the face for a distance of 10 cm.

Beds and joints: Not to exceed 1 cm thick. The face stones shall be laid alternate headers and stretchers.

Height of course: Each course shall consist of stones of even thickness not less than 15 cm. No stones in face shall have less breadth than height, and no stone shall tail into the wall less than its height and at least 1/3 of the face. Stones shall tail into the wall twice their height.

Bond or through stones: Through stones going right through the wall for walls up to 75 cm thick, shall be inserted in each course at 1.5 intervals breaking joints with similar stones in courses above and below at least 60 cm.

Quoins: Short bed to be at least equal to height and long bed at least equal to twice height. Beds and joints to be squared back as for walling.

#### c) Ashlar:

Every stone shall be chisel-dressed on all beds and joints, to be true and square giving perfectly vertical and horizontal joints with the adjoining stones or brickwork (three-line dressed).

Beds and joints: No joint shall be thicker than 1 cm. The face stones shall be laid alternate headers and stretchers; the headers shall be arranged to come as nearly as possible in the middle of the stretchers above and below so that the stones break joint on the face for at least half the height of the course.

Height of course: Not less than 30 cm. No stone to be less in breadth than in height, or less in length than twice its height.

Bond or through stones: Not exceeding 1.80 m apart in the clear, and to be staggered. In walls 75 cm thick and under, the headers run right through the wall, if more, overlap at least 15 cm.

"One line dressed" means sparrow picked or chisel-dressed so that no portion of the face dressed is more than 1 cm from edge of a straight edge laid along face of stone.

"Two line dressed" means sparrow picked or chisel-dressed so that no portion of the face dressed is more than 0.5 cm from edge of a straight edge laid along face of stone.

"Three line dressed" or fine chisel dressed means that the surface of the stone is dressed until a straight edge laid along the face in contact at every point, this is also called "plain face".

2 CONCRETE

Concrete is used for the construction of retaining walls, weirs and for bank stabilization. For more stability concrete is often reinforced with steel bars. Gravel used in concrete should not contain stones of more than 7 cm diameter. The following tables give the proportions of the mixture and the quantity of cement required for concrete of different mixing ratios.

Table 10 Proportion of cement, sand and gravel in concrete mixtures

Kind of concrete	Water content (percent)	Cement Sand Gravel (ratio by weight)
Compressed concrete for retaining walls	4-7	1 : 2 : 3
Compressed concrete for wing walls, weirs	4-7	1 : 2 : 2

Table 11 Quantity of cement required for concrete of different mixing ratios

Ratio	Kg Cement / cu. m concrete
1:1	900
1:2	630
1:3	460
1:4	350
1:5	300
1:6	250
1:7	225
1:8	200
1:9	175
1:10	150
1:12	125

Concrete reinforced with iron requires more water. Compressed concrete is processed by compacting layers of 15 to 20 cm, particularly the corners and edges of

the concrete mass, with a stamper. Special cements (so-called hydraulic cements) are employed for construction works in water. Ordinary concrete structures should not get in contact with water until completely hardened. The disadvantage of masonry and concrete structures in antierosion works is that they are very inflexible. Once damaged, they are not easy to repair.

You will find more information about concrete in common handbooks!

### 3 GABIONS

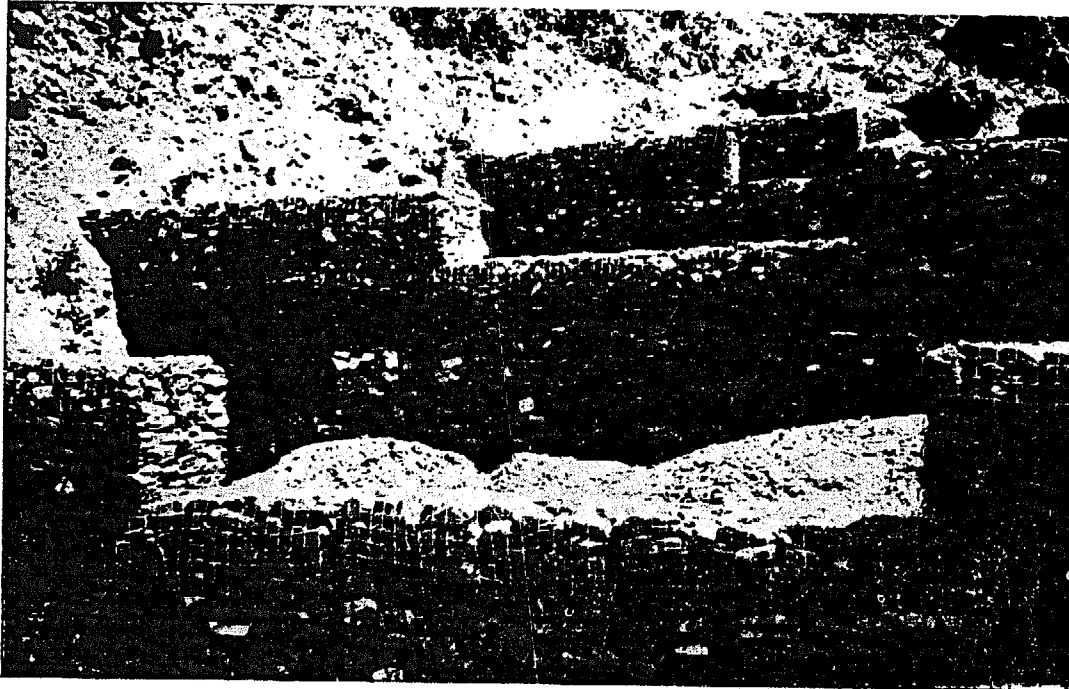

Photo No 6  
Gabion check-dam after construction  
with no spillway section protection.

Gabions is the term for large rectangular wire crates that are filled with stones and are employed in erosion control techniques which have been developed in Italy. They have some significant advantages over solid structures:

- flexible: Gabiones bend without breaking, and in contrast to concrete or masonry with mortar do not crack. This can be an important aspect with regard to unevenly sinking foundations and the pressure in slopes.
- permeable: Gabion structures are permeable and do not need an extra drainage system.



- economical: Usually they are cheaper to construct than other solid engineering structures. They may become expensive only where stones are not available in sufficient quantity.

Gabions can be used in flowing water and for land reclamation along shores, for retaining walls, gully stabilization, etc. They mainly serve as hydraulic structures.

a) Construction:

Since ready-made imported gabions are very expensive and hardly available, wire crates have to be constructed from locally available mesh wire. The wire should be heavily galvanized to insure a long life span. The standard of the galvanisation must be checked with every supply and must be up to the standard (see for instance British Standard). The diameter of the wire should not be less than 2.5 mm; recommended are 2.8 or 3.0 mm. Gabions can be divided by so-called diaphragms to increase their stability and to prevent the internal movement of the stone fill.

For a gabion of 2x1x1 meter the following material is required:

- 1 piece of mesh wire 4x2 m = 8 sq. m,
- 2 pieces of mesh wire 1x1 m = 2 sq. m,
- 12 m iron rod 0.5-0.7 cm diameter,
- approximately 10 m wire for sewing.

At first the 4 m piece of mesh wire is spread on the ground. Then, the two smaller pieces are connected with the main body one meter from either end as shown in Fig. 19. To strengthen the gabion an iron rod is fixed around the edges of the main mesh wire body and tied together where its two ends meet. To steady the gabion during filling it would be also possible to use thin bamboo or wooden poles as a substitute, should funds be lacking to buy the iron rod. These poles should not be too thick, so as not to leave large hollows in the gabion after they have decayed.

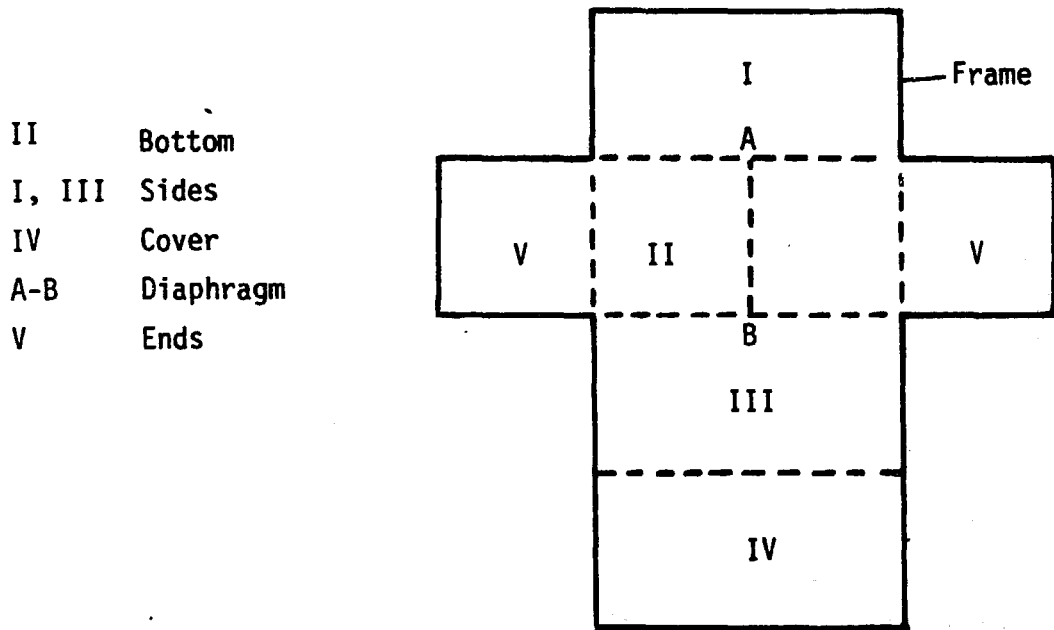

Fig. 19 Construction of a Gabion

Gabions can also be manufactured from ordinary wire. The procedure requires some skill and experience.

b) Assembling of gabions:

For better handling gabions are usually delivered flat-folded. On a level spot near the construction site they are opened, their sides folded up and the edges sewn together firmly with wire, which must be looped twice through every mesh opening along the edges. It should be as strong as the mesh wire of the gabion.

c) Filling:

Care must be taken that the gabion does not lose its shape. Therefore double strands of wire are stretched across the box and single wires tied diagonally at the edges. For better support these wires should be looped around at least two meshes (Fig. 20). Without the cross-ties the gabion tends to adopt the shape of a sausage.

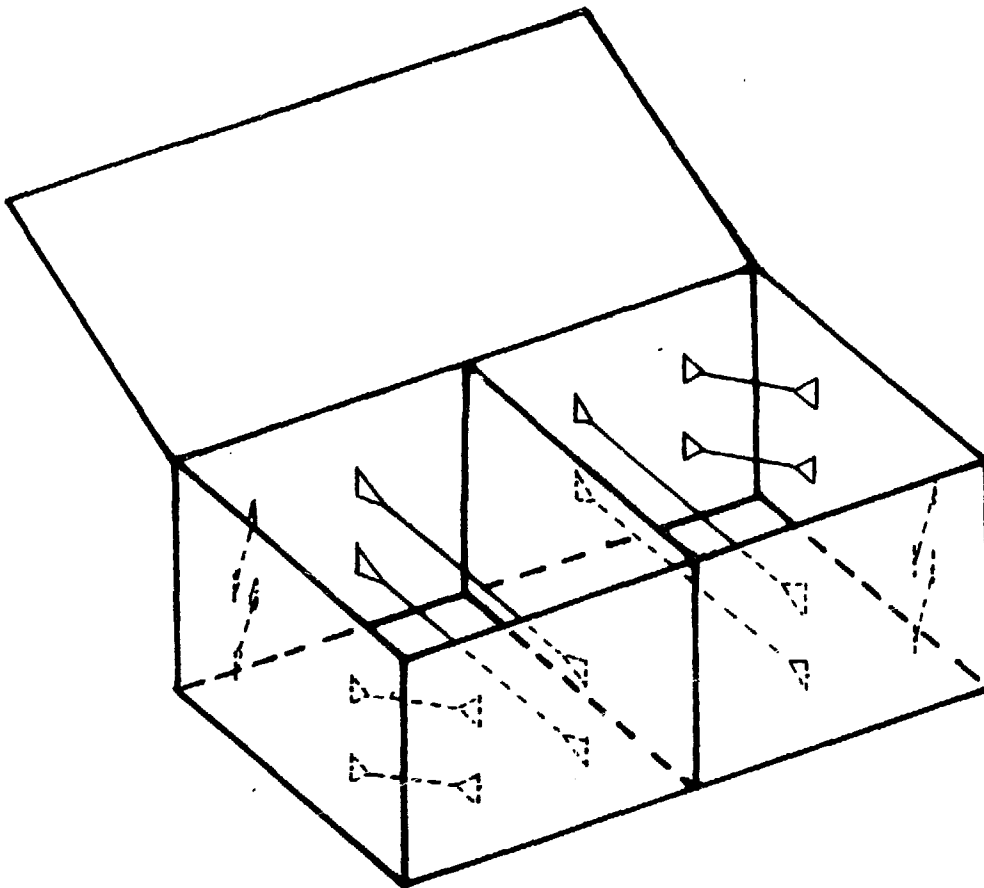
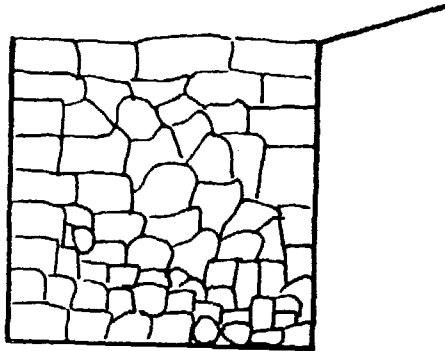
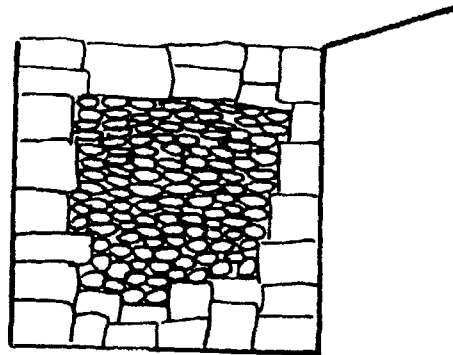

Fig. 20 Stabilisation of a Gabion by Cross Ties

The stones for the filling should be larger than the size of the meshes. The front of the gabion requires more riprapping, whereas for the back or inner side a rough filling may be sufficient. If there are not enough stones, the center can also be filled up with gravel (Fig. 21).



Gabion filled with large material, front side riprapped



Gabion filled with bigger material at the outside, finer material in the middle

Fig. 21

Filling of a Gabion

After filling, the cover of the gabion is bent down, pulled tight with the help of a crowbar and sewn along the front edge and the sides. Most structures (retaining walls, checkdams, etc.) require several gabions, which are connected likewise by strong galvanized wire. A detailed instruction sheet is given in Appendix 6.

V P R E P A R A T I O N   O F   C O N T R O L  
P R O P O S A L S

---

The first step in the preparation of control proposals is the Preliminary Investigation which is based on a field trip covering the river and the eroded areas and on the map of 1:50 000 or 1: 63 660 scale. The result of the preliminary investigation is a report describing the situation ( river condition, erosion, damages and dangers), giving the easily available facts on hydrology, geology, land use and economy of the area and prescribing the measures required with a rough cost estimate based on the number of structures and their approximate sizes. Usually the benefits are enumerated or described but not given in figures in order to produce this report as fast as possible.

Based on this preliminary report it has to be decided whether within the district the damage or danger caused by the river under consideration is important enough to expend funds from a limited budget to prepare a detailed control proposal. If the priority of a certain erosion control scheme is established the preparation of a detailed control proposal is started. It consists of the following steps:

- Topographical survey and collection of data
- Planning
- Presentation

Topographical Survey and Collection of Data: The topographical survey is normally conducted with a transit with an accuracy for the horizontal angle of at least 10' and for the vertical angle of 1'. Distance and height difference are computed from optical transit readings. The main survey traverse is preferably a compass-traverse with two transfer-stations between the transit stations.

1. Map 1: 500-2000
2. Longitudinal Section of the River 1: 100-200 (height scale)  
500-2000 (longitudinal scale)
3. Cross Section 1: 100-200

In this survey have to be included all river points necessary to draw a horizontal and vertical projection of the river (points where the river changes direction or gradient, points above and below falls, upper and lower end of bed-rock or heavy boulder etc.). In addition, stations have to be taken along the edge of slides, along lines where the slope gradient changes strongly, along roads, locating also drains, and stations outlining existing structures like houses etc. The survey should be extended down to the junction with the next bigger river and up-river some distance above the uppermost control measure. Only where the stretches needing treatment are far above the junction and where at the lower end of this stretch solid bed-rock for check-dam foundation is available the survey can be started at this rock.

In addition all available data about

- Size of drainage and topography
- Rainfall and particularly its maxima
- Geology

nave to be collected. From catchment area and rainfall data (and if available, out of hydrological data) flood run-off is estimated. New surveys in addition to existing data about geology and land use are only conducted if their knowledge is essential for planning or execution of the control work and then only for areas where it is necessary. Data on labour and material cost and on cost of transport of material are essential for reliable cost estimates.

Planning: From the longitudinal section and cross sections, the rise in bed level required to stabilize the eroded slope is derived. The number and location of check-dams and embankments is designed accordingly and their horizontal outline established in the map. With the help of the estimated flood run-off the required river cross-section area and spillway sizes are calculated. With these data the single structures are designed as cross-sections. Out of these the volume of work for excavation, gabion, masonry, concrete etc. is calculated. Costs per unit for material, labour and transport are established for the proposed types of work. The volume of work times unit costs summed up give the cost estimate. Vegetative measures are treated in the same way either on an area basis per hectare or on a basis of length per metre for cordons etc.

The cost estimate is normally done in the sequence of work from the mouth up-river and with the work outside the river like drainage and vegetative measures last. Sub-totals are added up for each structure separately and to the grand-total a sum between 15 and 25 % added for contingencies and overhead. Although this sum looks rather high, flood-damages during construction and additional measures not foreseen in the proposal can not be avoided in erosion control.

Presentation:

The Detailed Erosion Control Proposal consists of:

1. The Technical Report: presenting the above mentioned data, describing the river and erosion conditions and explaining the proposed measures and their calculations. Costs and benefits at least in approximate figures are compared.
2. Map 1: 50 000: showing the project area in relation to the district and to the existing transportation network. In this map the drainage area and afforestation areas are outlined.
3. Map 1: 500-2000: showing the proposed structures in and along the riverbed and all measures outside it.
4. Longitudinal Section 1:  $\frac{100-200}{500-2000}$ : shows all structures in and along the riverbed.
5. Cross-Sections 1: 100-200: show the detailed design of every single structure.
6. Table of Costs per unit: shows the calculation of costs per unit for every type of work appearing in the control proposal.
7. Cost-Estimate: shows the calculation of volumes and costs for each structure and other measures and the calculation of the total cost.
8. Table of land users: e.g. Panchayats, timber concessionaires, water rights.
9. Photographs: should illustrate the project area as a whole and show interesting details.

SITUATION

1 : 1000

THEODOLITE-STATION  
TRANSFER-STATION  
SURVEY POINT

CROSS-SECTIONS

1 : 100

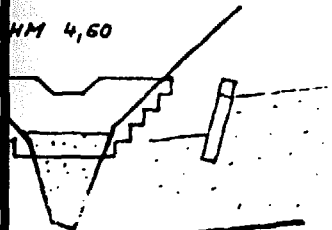
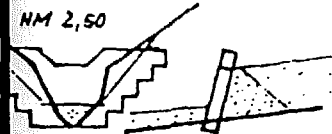
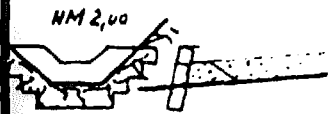

LONGITUDINAL SECTION

100 ELEVATIONS  
1000 DISTANCE

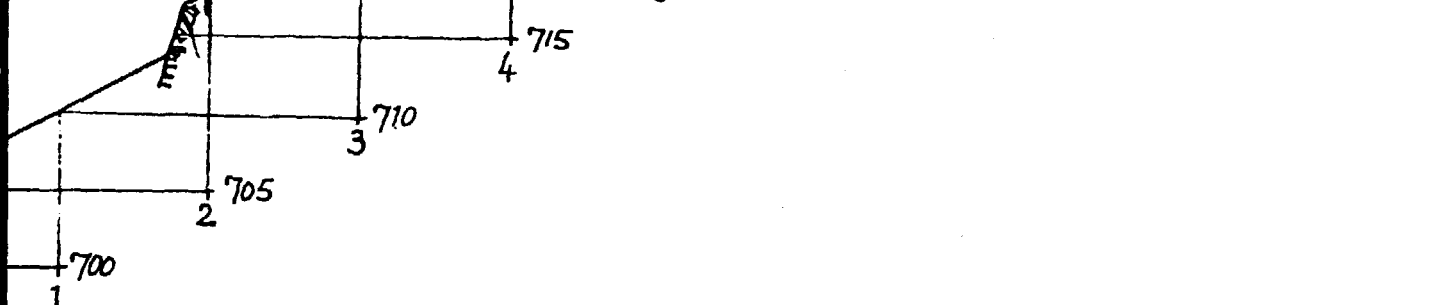

Fig. 22 Situation, Cross-Sections and Longitudinal Section of a Control Proposal

## VI P R O C E D U R E

### 1 PRIORITY AT STARTING PROJECTS

When beginning a new project one always has to ask the question which area or which gully has to be worked on first. A master plan can help to solve this problem.

Normally the work starts in one sub-catchment in an integrated way (check-dam and embankment construction, afforestation, grassplantation, terrace improvements, etc.). The sub-catchment (or gully) can be selected according to the following considerations:

- demonstration character
- protecting infrastructures (roads, channels, houses)
- political reasons
- sub-catchment condition
- accessibility
- getting experience

### 2 SUCCESSION IN ONE GULLY

The succession of the work must be arranged according to their purpose and the local situations.

Normally in a series of check-dams the lowest ones (which support the others) are built first. In practice the best order is to start with the lowest check-dam. After its completion the next higher one is started. This has the advantage, that the excavation material can be used as fill material. In this way no special soil deposition is needed, and the deposition does not block the water course.

When a contractor does the job, construction time is limited. Then he normally starts by excavating for all the check-dams at the same time and afterwards starts the construction. This order should be avoided, to take the excavation material as fill. In this case the order of working must be prescribed firmly in the specifications (construct first the lowest check-dam, after its completion start with the excavation of the next higher one, etc.). The time of construction must be fixed accordingly!

Where a high sole lift is required and the upper check-dam stands on the lower fill, the construction can only start after filling, that means after the next monsoon (consolidated deposition material has still some settlement, so the construction on such artificial fill is risky). To construct a check-dam each year, special timing must be foreseen in the project plan!

There is one difficulty in selecting the check-dam height and the construction site. To solve it there are two alternatives:

First alternative: Before the survey starts, the engineer decides on the fall height of the check-dams (e.g.  $h_f = 2.00$  m). For the survey he decides where the lowest one has to stand, and surveys there the cross section. The place of the next upper check-dam is set according to the fall height, and there also the cross section is surveyed etc. This order has the advantage that all check-dams have the same height. This simplifies the design, but it has the disadvantage, that local situations can not be considered.

Second alternative: The survey with its cross sections is made at important and characteristic points. In the office, using this survey, a rough project is calculated and estimated with two or more different heights of check-dams. During the construction the engineer places the check-dams according to the local situations (good foundation, bottleneck, big stones) and selects the required height, so that it will fit into the series. In this way many changes from the initial plan and many adaptations must be made. But the construction can take advantage of the best local situation. This second alternative leads to the better result!

### 3 ITINERARY FOR CONSTRUCTION

The order of work for the construction of a check-dam gives the network diagram in Fig. 23.



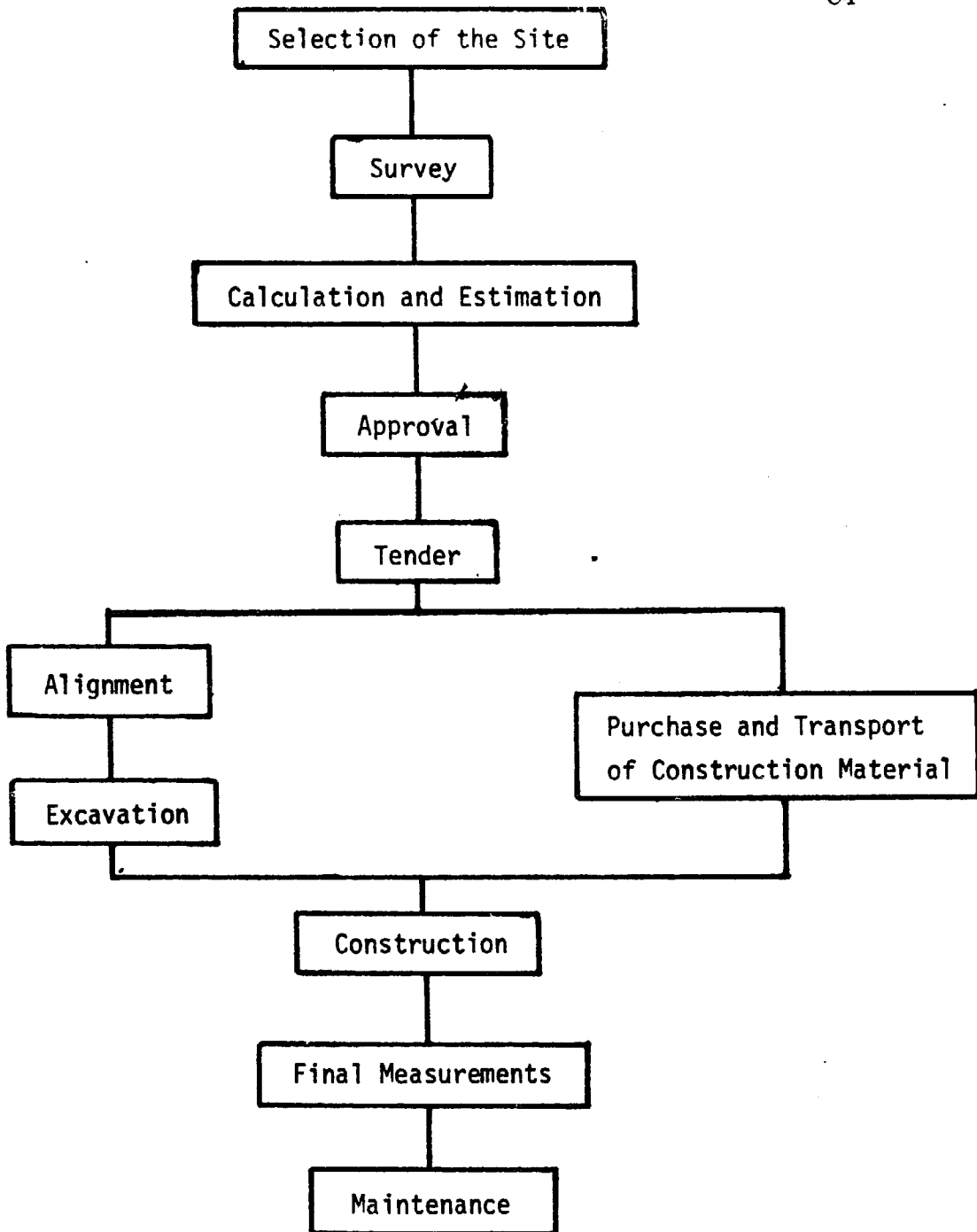

Fig. 23 Network Diagramm of Construction

## VII MAINTENANCE

---

Maintenance of structures and the care of plantations and vegetative methods of slope stabilization are very important. Structures which are not maintained can have disastrous consequences for the people staying downstream by possible destruction through floods. For maintenance there is a proverb saying:

"If there is no will and the required means are not available to maintain the structures sufficiently, it is better to relinquish the construction!"

### Photo No 7

The water flows beside the check-dam and attacks the bank. Maintenance is badly needed!



Normally maintenance and care consist of:

- inspections
- care of plantations, drain-system and watercourses
- repair work
- supplementary work

These tasks have the aim:

- to guarantee the longest lifespan (if possible without or at least a very late reconstruction)
- to discover and to repair new damages in slopes and torrents as soon as possible

- to discover in sufficiently protected areas, those which need supplementary work.

For the single tasks the following must be mentioned:

a) Inspections

A check-up must be done before and after the monsoon. Basically all structures, watercourse (sole- and bank erosion, obstacles etc.) and slope-protections must be checked.

b) Care of plantations and of watercourses

This consists of:

- Drainage: To clean out ditches, remove weeds, and to repair ditches
- Slopes: Where necessary grass cutting, restoration of grass cover, cutting of the bushes to mend and to supplement afforestation, to check newly formed rills, gullies and slides with brush-wood check-dams and with other vegetative methods of slope stabilisation.
- Water Courses: To clean the watercourses from deposits, especially from floating wood, big stones, weeds etc. Erosion trends must be recognized and controlled immediately. Changes of water courses must be monitored and controlled.

c) Repair work

This concerns especially structures in masonry, wood and vegetative methods of slope stabilisation:

- Retaining walls: All kind of retaining walls as well as check-dams and embankments have to be checked for: condition of the foundations, pressure-indications (specially in dry-masonry-structures), settlement, degree of derangement, functioning of drains, damage due to rotting, hitting and abrasion etc.
- Check-dams: have to be checked additionally for the condition of the spillway section, scouring damage above and below the structure, bank foundations condition of the apron and the scouring-basin, scouring activities in the banks etc.  
With all these structures every damaged part has to be changed or patched up. Scouring damage must be repaired by setting a better protection (big stones, masonry, gabions etc.). Often it is not possible to repair rotting check-dams. They have to be exchanged by removing the old one (which is very dangerous) or by constructing a new one in front of the old one. A replacement is normally built in concrete. The replacement of whole check-dams does not belong to the annual maintenance. For such a project a special budget is needed.
- Vegetative Methods of Slope Stabilisation: Outwashing of brush-wood check-dams must be restored and dead plants replaced, possibly done with fertilizer.

d) Supplementary work

Normally it is not possible to be completely successful at the first attempt. Especially in new constructions and young plantations, damage often exceeds routine maintenance. New bank protections are necessary, drains must be extended; new retaining structures are necessary. For that purpose special budgets with higher amounts are needed in the first few years in contrast to normal routine maintenance.

e) Maintenance operations

For the maintenance of structures and plantations a responsible, trained and skilled group is needed for each catchment. The size of the group is determined by the extent of the catchment.

Between 15 and 20 % of the annual construction budget should be spent on maintenance!

Make it a rule:

"The better the maintenance, the lower the cost in the long run and the more effective the conservation work!"

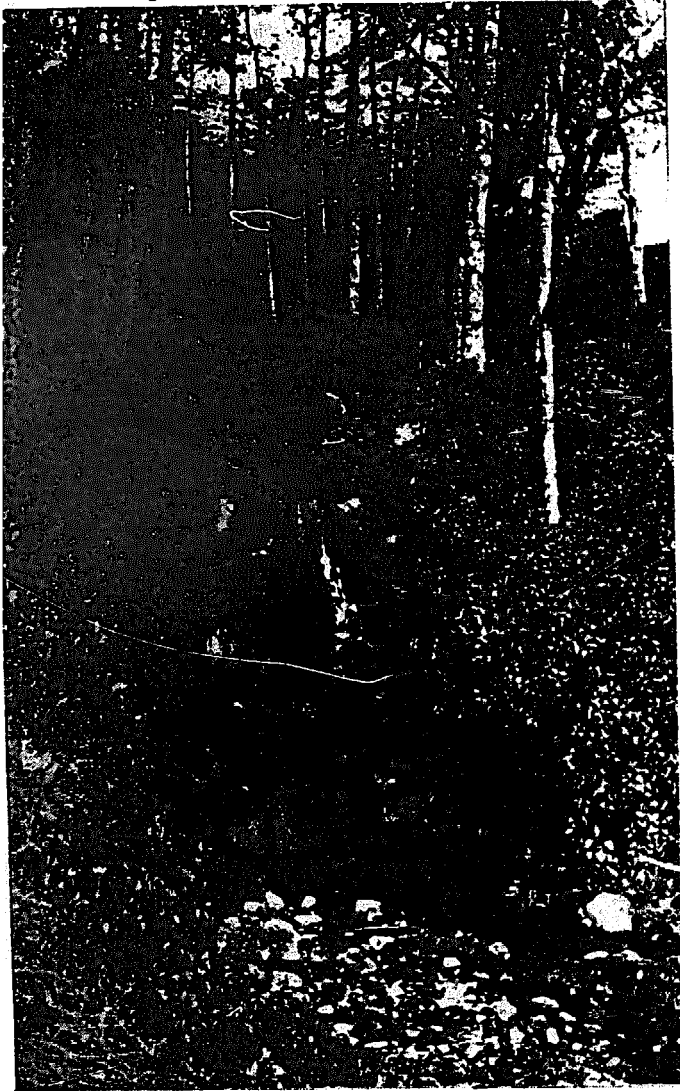

Photo No 8

Grass sodging on a trimmed slope.



Photo No 9

Dry masonry check-dams with afforestation. From outside you can not see the check-dams series. It is a forgotten story!

## VIII SUGGESTIONS

---

For future successful work in erosion control I suggest the following:

1) Construct check-dams only along with treatment of the upper catchment and the adjacent slopes:

- plantation of grass
- afforestation
- diversion channels
- draining of oversaturated soils
- trimming steep slopes down to the natural angle of repose
- vegetative methods of slope and gully stabilisation

These points are very important. They are not treated in this manual. But they are as important as the construction of check-dams and need your full attention! Often with these measures the construction of check-dams is no longer necessary! (A good guideline for vegetative methods of slope and gully stabilisation is in the "Manual of Reforestation and Erosion Control for the Philippines".)

2) The estimation of run-off is always difficult, because of lack of stations in the catchment area. For better hydrological data install and operate rainfall gauges and water gauging stations (staff gauge), with the collaboration of the Department of Meteorology and Hydrology.

3) To estimate the quantity of landslide material, bed load and depositions is very difficult. Normally, estimates are based only on optical observations. To get exact data a catchment should be surveyed every five years. Additionally, after a disaster a longitudinal section of the main gullies and the main riversystem, and a cross section at the important places should be made. In this way a cutting or a deposition can be estimated more accurately.

4) Maintenance is as important as the construction itself. Do not forget the proverb: "Don't start construction if there is no will to maintain!"

5) With the tender system (which is the normal procedure for bigger constructions) a new contractor comes for every project. According to the HMG "Rules and Regulations" the cheapest contractor gets the job. Often a contractor who has little idea about the work gets the job. This is the reason for his low tender, and the work is accordingly of low quality.

Conclusion: Tenderers should clearly state their qualifications and previous experience. Persons awarding contracts must be prepared to justify their choice of the best rather than the cheapest tender. Furthermore they should try to build up a few experienced contractors with skilled labourers. This is in the interest of Nepal's development aims.

6) An even better solution than the experienced contractors, would be responsible working groups employed by the department (or project). Such a skilled group with

the required material could do all the construction work in one or few project areas. For bigger work local people could be hired as labourers. Such a group would also have the advantage that it could do the maintenance as it occurs because the group stays in place. The group would also relieve much of the project's engineer and overseers heavy work load.

Such a working group would be the most effective way of getting the work done.

7) After a disaster (big landslide or gullying) it is often important to start the control work immediately to safeguard infrastructures. Each day can be important! Money and material should be ready to start with the control work, without adhering to timeconsuming procedures. The required authority should be delegated to the concerned project-in-charge (even if limited). Only in this way a disaster can be checked without causing subsequent heavy losses. This is fundamental to disaster planning.

IX B I B L I O G R A P H Y

---

- (1) Strele, G., Grundriss der Wildbach- und Lawinenverbauung, 1950 Springer Verlag, Wien.
- (2) ASF, Dimensionierung von Wildbachsperren aus Beton und 1973 Stahlbeton, EDMZ, Bern.
- (3) Khanna, P.N., Indian Practical Civil Engineers' Handbook, 1979 Engineers Publishers, New Dehli.
- (4) Hudson, N., Soil Conservation, 1976 B.T. Batsford Limited, London.
- (5) Ven te Chow, Open-Channel Hydraulics, 1959 Mc Graw Hill, New York.
- (6) GTZ, Manual of Reforestation and Erosion Control 1975 for the Philippines, GTZ, Eschborn.
- (7) FAO, Guidelines for Watershed Management, Conservation 1977 Guide 1, FAO, Rome.
- (8) FAO, Hydrological Techniques for upstream Conservation, 1976 Conservation Guide 2, FAO, Rome.
- (9) Tautscher, O., Torrent and Erosion Control, 1974 FAO, No TA 3286, Rome.
- (10) Tautscher, O., Torrent and Erosion Control, 1977 Seminar on Mountain Ecosystem, Kathmandu.
- (11) British Standards Institution, Gr 2, Mild Steel Wire.
- (12) British Standards Institution, Gr.4, Specification for Galvanized Coatings on Wire.
- (13) Bannister, A. & Raymond, S., Surveying, The English Language 1972 Book Society and Pitman Publishing.
- (14) Zeller, J., Vorlesung: Wildbach- und Hangverbau, ETH, Zurich.
- (15) Climatological Records of Nepal, 1971-1975, Vol 1

A P P E N D I X 1

---

ESTIMATION OF THE BIGGEST STONE SIZE TRANSPORTED BY WATER

It gives an approximate value of the biggest diameter of the stones transported by the water in interdependence of the gradient, height of the river and its roughness. Use this formula during construction to select stones big enough for the structures!

$$d = \frac{Jh}{n}$$

Where d is the biggest diameter of the transported stones in m  
J is the gradient of the river in m/m  
h is the water depth of the river in m  
n is the roughness coefficient, take 0.05

Example

J (m/m)	h (m)	n(-)	d(m)
0.02	0.5	0.05	0.2
0.02	1.0	0.05	0.4
0.02	1.5	0.05	0.6
0.03	0.5	0.05	0.3
0.03	1.0	0.05	0.6
0.03	1.5	0.05	0.9
0.05	0.5	0.05	0.5
0.05	1.0	0.05	1.0
0.05	1.5	0.05	0.5

Remark: According to the observations in the field the refillment upstreams of a check-dam has a gradient between 0.02 and 0.03 (= 5°).

This empirical formula has been derived by Mr. A. von Steiger, Switzerland.



A P P E N D I X 2

---

SURVEY CALCULATION EXAMPLE

Two examples are calculated according to chapter I Table 1 step by step. The theodolite has a  $360^{\circ}$  index. The zero in the vertical angle is on the bottom ( $\alpha < 90^{\circ} \rightarrow$  sight downwards,  $\alpha > 90^{\circ} \rightarrow$  sight upwards). In Table 2 the same example is calculated with a programmable calculator.

Example of Run-Off Calculation

(There is no relation between the different examples!)

1. The Rational Formula1.2 Time of Concentration

$$L = 1.2 \text{ km}, \quad A = 2.1 \text{ km}^2, \quad J = 10 \frac{\text{m}}{100 \text{ m}}$$

$$T = \frac{L}{1.5 \sqrt{A} \frac{4}{\pi}} \cdot \sqrt[5]{\frac{A^2}{J}} = \frac{1.2 \text{ km}}{1.5 \sqrt{2.1 \text{ km}^2} \frac{4}{\pi}} \cdot \sqrt[5]{\frac{(2.1 \text{ km}^2)^2}{10 \frac{\text{m}}{100 \text{ m}}}}$$

$$\underline{T = 0.42 \text{ h} = 25 \text{ min}}$$

1.3 Intensity by Formulaa)  $t = 5 \text{ min}$  Rainfall of 20 years

$$\underline{\underline{I_{5 \text{ min}}}} = \frac{a}{b+t} = \frac{2850}{10+5} = \underline{\underline{190 \text{ mm/h}}}$$

b)  $t = 30 \text{ min}$  Rainfall of 20 years

$$\underline{\underline{I_{30 \text{ min}}}} = \frac{2850}{10+30} = \underline{\underline{71.2 \text{ mm/h}}}$$

1.4 Intensity by Graph (data see bibliography 15)

a) Station 1415 Sanishhare 168 m MSL

year	$h_{24 \text{ max}}$
1972	168
1973	176
1974	247
1975	168

$$h_{24 \text{ max}} \text{ in 4 years} = 247 \text{ mm}$$

$$h_{24 \text{ max}} \text{ in 25 years} = 247 \frac{1.25}{0.98}$$

(table 4) = 332 mm

at t = 10 min (see fig 4) → I<sub>10 min</sub> = 290 mm/h  
 at t = 30 min → I<sub>30 min</sub> = 195 mm/h

I<sub>24</sub> =  $\frac{332}{24} = 13.8 \text{ mm/h}$

b) Station 0809 Gorkha 1097m 175L

year	h <sub>24 max</sub>
1971	78
1972	97
1973	81
1974	95
1975	102

at t = 5 min (see fig 4) → I<sub>5</sub> = 170 mm/h  
 at t = 30 min → I<sub>30</sub> = 86 mm/h

h<sub>24 max</sub> in 5 years = 102 mm  
 h<sub>24 max</sub> in 25 years = 102  $\frac{1.25}{0.95} = 134 \text{ mm}$

I<sub>24</sub> =  $\frac{134}{24} = 5.58 \text{ mm/h}$

1.5 The Rational Formula

catchment characteristics: rock, but wooded → C = 0.8  
 I = 86 mm/h; A = 210 ha

$$Q = \frac{0.80 \cdot 86 \text{ mm/h} \cdot 210 \text{ ha}}{360} = 40.1 \text{ m}^3/\text{s}$$

## 2. The Manning Formula

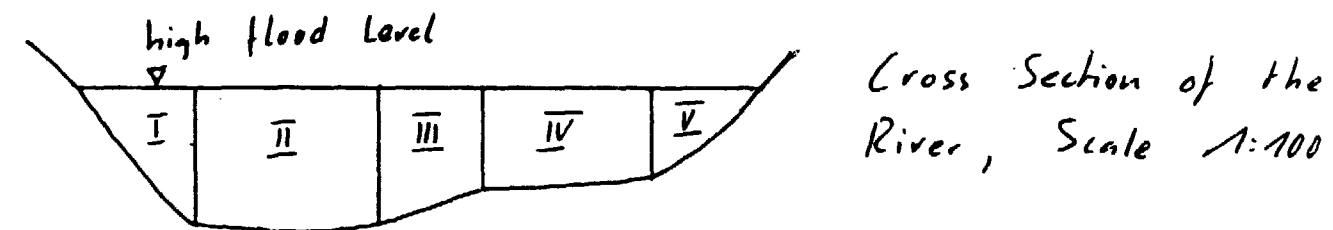

No	Length	height	Form	Area	wet Surface
I	1.5	1.8	▽	1.35	2.4
II	2.5	1.8	□	4.50	2.5
III	1.3	1.5	□	1.95	2.4
IV	2.2	1.2	□	2.64	2.7
V	1.4	1.2	▽	0.84	2.0

11.28 m<sup>2</sup> 12.0 m

$$\theta = 5^\circ \rightarrow \tan 5^\circ = 0.087 \text{ m/m}$$

rill in mountain, sole stones and big blocks  $n = 0.05$

$$Q = \frac{1}{0.05} \cdot \frac{11.28^{5/3} \cdot 0.05^{1/2}}{12^{5/3}} = \underline{\underline{4.03 \text{ m}^3/\text{s}}}$$

$$v = \frac{Q}{A} = 36 \text{ cm/sec}$$

3. Empirical Relation

The adjacent catchment has an area of  $5.6 \text{ km}^2$  and a peak run-off (at the water gauging station) of  $Q_{\max} = 107 \text{ m}^3/\text{s}$ .

A catchment with an area of  $1.8 \text{ km}^2$  has therefore a peak-run-off of

$$\underline{Q_{\max}} = 107 \cdot \frac{\sqrt{1.8}}{\sqrt{5.6}} = \underline{60 \text{ m}^3/\text{s}}$$

Check Dam Design Calculation Example

1. Run-off see annex 3

2. Hydraulic Elements

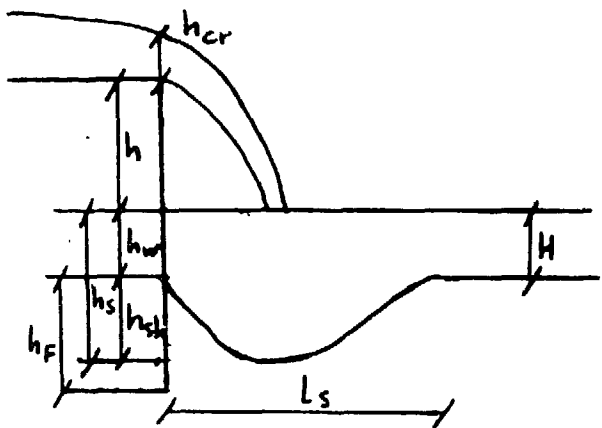

Given:  $Q = 7.5 \text{ m}^3/\text{s}$   
 $B_{sp} = 5 \text{ m}$   
 $h = 2.60 \text{ m}$   
 $d_{gs} = 40 \text{ cm}$

$$q = \frac{7.5}{5} = 1.5 \text{ m}^3/\text{s} \cdot \text{m}$$

$$h_{cr} = \sqrt[3]{\frac{1.5^2}{9.81}} = 0.61 \text{ m}$$

$$H = h_w = \frac{3}{2} \cdot h_{cr} = 0.92 \text{ m}$$

$$h_s = 0.79 \frac{2.6^{0.343} \cdot 1.5^{0.686}}{0.4^{0.372}} = 2.04 \text{ m}$$

$$h_{sh} = h_s - h_w = 2.04 - 0.92 = 1.12 \stackrel{ok.}{\approx} 1.50 = h_F$$

$$L_s = 0.73 \frac{2.6^{0.457} \cdot 1.5^{0.914}}{0.4^{0.828}} = 3.49 \text{ m}$$

$$b_{sh} = 1.5 \cdot B_{sp} = 7.5 \text{ m}$$

# Gabion Check Dam, Example

Front View

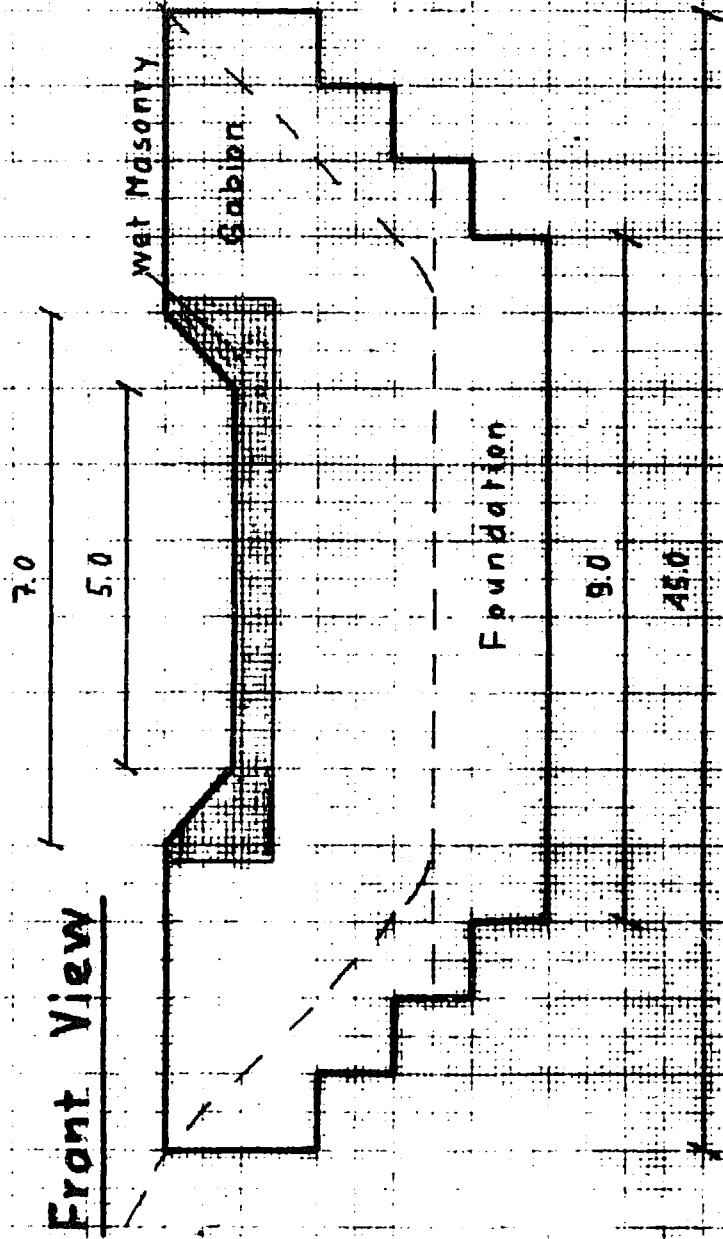

Cross - Section

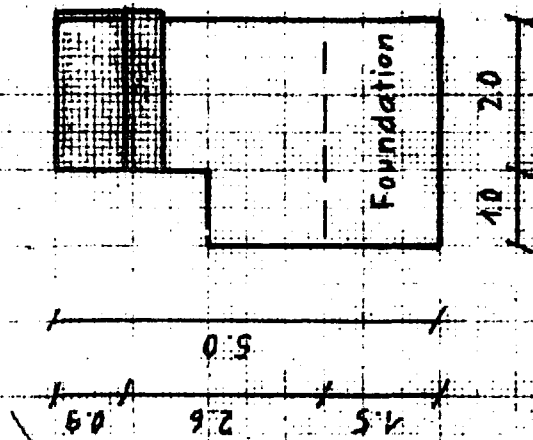

Plan

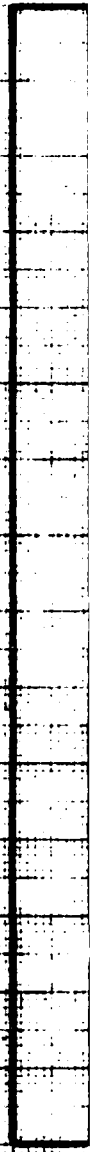

Scale 1:100

Measurements in m

### 3. Geometry of the Check Dam

see Gabion Check Dam, Example

### 4. Strains per meter strip

#### 4.1 Own Weight

$$\gamma_{\text{concrete masonry}} = 2.4 \text{ t/m}^3$$

$$\gamma_{\text{gabion}} = 2.1 \text{ t/m}^3$$

$$W_{\text{mas}} = 2.1 \cdot 0.5 \cdot 1.0 \cdot 2.4 = 1.05 \cdot 2.4 = 2.52 \text{ t}$$

$$W_{\text{gab}} = (2.0 \cdot 0.6 + 3.0 \cdot 3.0) \cdot 1.0 \cdot 2.1 = 10.8 \cdot 2.1 = 22.68 \text{ t}$$

$$W_{\text{total}} = 25.20 \text{ t}$$

#### 4.2 Hydrostatic Waterpressure

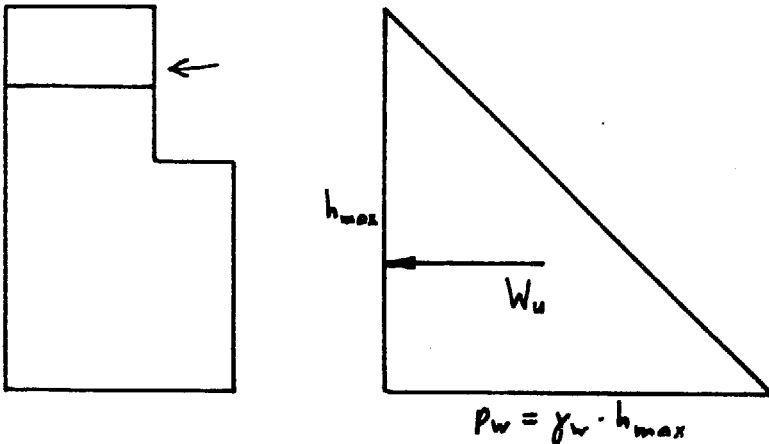

$$p_w = 1 \cdot 5 = 5 \text{ t/m}^2$$

$$W_0 = \frac{1}{2} h_{\text{max}} \cdot p_w \cdot 1 \text{ m} = 12.5 \text{ t}$$

#### 4.3 Normal Case (Strain Case 1 and 2)

##### a) Overturn

$$M_{\text{st}} = 1.05 \cdot 2.4 \cdot 1 \text{ m} + 2 \cdot 3.6 \cdot 2.1 \cdot 1 \text{ m} + 3 \cdot 2.1 \cdot 2.5 \text{ m} \\ = 33.39 \text{ m t}$$

$$M_0 = W_0 \cdot h_{\text{max}} / 3 = 12.5 \cdot 5 / 3 = 20.83 \text{ m t}$$



$$\eta_0 = \frac{M_{st}}{M_0} = \frac{33.39}{20.83} = 1.60 \geq 1.2 \quad \text{ok}$$

b) Sliding

$$F_{res} = W \cdot \mu = 25.20 \cdot 0.6 = 15.12 +$$

$$F_{driv} = W_0 = 12.5 +$$

$$\eta_s = \frac{F_{res}}{F_{driv}} = \frac{15.12}{12.5} = 1.21 \geq 1.2 \quad \text{ok}$$

c) Bearing Pressure

$$P_{real} = \frac{W}{3.1} = 8.40 \text{ t/m}^2$$

$$P_{ad} = 50 \text{ t/m}^2 \quad (\text{gravel})$$

$$\eta_p = \frac{50}{8.40} = 5.95 \geq 1.2 \quad \text{ok}$$

d) Pressure Line

$$e = \frac{M}{W} = \frac{20.83}{25.20} = 0.83 \stackrel{?}{\leq} 0.50 = t_F$$

The construction material is gabion and it can take some tractive forces. In addition the <sup>vertical</sup> soil component is neglected. So the structure will stand.

4.4. Mudflow Case (Strain case 3)a) Overturn

$$M_{st} = 33.39 \text{ mt} \quad \text{see 4.3}$$

$$\begin{aligned} M_0 &= \left(3 \cdot \frac{1}{2} \cdot h_{sp}^2 \cdot \gamma_w\right) \left(h_d + \frac{h_{sp}}{3}\right) + \left(\frac{1}{2} \cdot h^2 \cdot \gamma_s\right) \left(h_F + \frac{h}{3}\right) \\ &= \left(3 \cdot \frac{1}{2} \cdot 0.9^2 \cdot 1\right) \left(4.1 + \frac{0.9}{3}\right) + \left(\frac{1}{2} \cdot 2.6^2 \cdot 2\right) \left(1.5 + \frac{2.6}{3}\right) \\ &= 5.35 + 16.00 = 21.35 \end{aligned}$$

$$\eta = \frac{33.39}{21.35} = 1.56 \geq 1.2 \quad \text{ok}$$

b) Sliding

$$F_{res} = W_0 \cdot \mu = 15.12 +$$

$$F_{driv} = 3 \cdot \frac{1}{2} \cdot 0.9^2 \cdot 1 + \frac{1}{2} \cdot 2.6^2 \cdot 2 =$$

$$= 1.22 + 6.76 = 7.98 +$$

$$\eta_s = \frac{15.12}{7.98} = 1.90 \geq 1.2 \text{ ok}$$

c) Bearing Pressure see 4.3d) Pressure Line

$$e = \frac{21.35}{25.20} = 0.85 \stackrel{?}{\leq} 0.50 = t_F$$

same remark as in 4.3 d)

4.5 Disaster Case (Strain case 5)a) Overturn

$$M_{st} = 33.39 \text{ mt}$$

$$M_0 = \left( \frac{1}{2} \cdot h_{sp}^2 \cdot \gamma_w \right) \left( h_d + \frac{h_{sp}}{3} \right) + \left( \frac{1}{2} \cdot h_d^2 \cdot \gamma_s \right) \left( \frac{h_d}{3} \right)$$

$$= \left( \frac{1}{2} \cdot 0.9^2 \cdot 1 \right) \left( 4.1 + \frac{0.9}{3} \right) + \left( \frac{1}{2} \cdot 4.1^2 \cdot 2 \right) \left( \frac{4.1}{3} \right)$$

$$= 1.78 + 22.97 = 24.76 \text{ mt}$$

$$\eta_0 = \frac{33.39}{24.76} = 1.35 \geq 1.2 \text{ ok}$$

b) Sliding

$$F_{res} = W_0 \cdot \mu = 15.12$$

$$F_{driv} = \frac{1}{2} \cdot h_{sp}^2 \cdot \gamma_w + \frac{1}{2} \cdot h_d^2 \cdot \gamma_s$$

$$F_{\text{driv}} = 0.41 + 16.81 = 17.22 \text{ t}$$

$$n_s = \frac{15.12}{17.22} = 0.88 \geq 1.2 \quad \text{Wrong}$$

If this disaster case want to be considered, the design must be changed. Or a detailed check calculation is required, which takes all forces into account.

c) Bearing Pressure see 4.3

d) Pressure Line

$$e = \frac{24.76}{25.20} = 0.98 \leq 0.50 = t_F$$

see remark in 4.3 d)

In my opinion this check dam will stand, although some calculations are critical!

A P P E N D I X 5

SAMPLE OF COST ESTIMATION

his estimation shows the cost of one gabion check-dam with a cement masonry pillway-section as shown in A4. The rates are according to the construction place which was at Tansen (Palpa) in summer 1979. These rates must be verified for each construction according the local rates and the rise of prices.

he following pages show the calculation in detail:

- Abstract of Quantities
- Rate Analysis
- Abstract of Costs

According to these calculation one gabion check-dam costs Rs. 51,608/- (US\$ 4,336/-).

H.M.G. Nepal  
Ministry of Forest  
Department of Soil and Water Conservation

Abstract of Quantities

Sheet No. ... 1 ...

Place :-

Yr :- 1979

Name of Project :- Manual

Title :- Gabion Check Dam, Example

S.N.	Description	No.	Length ft/m	Bredth ft/m	Ht/depth ft/m	Qunt.	Remarks
1	Excavation		1.0	3.0	1.0	3.0	1st Layer
			3.0	3.0	1.0	9.0	2nd
			3.0	3.0	1.0	9.0	3rd
			2.5	3.0	0.5	3.75	} 4th
			11.0	3.0	0.5	16.5	
			9.0	3.0	1.0	27.0	5th
					68.25	m <sup>3</sup>	
2	Dry Masonry for Gabion Fill	8	2	1	16	1st Layer	
		15	2	1	30	2nd	
		13	3	1	39	3rd	
		11	3	1	33	4th	
		9	3	1	27	5th	
					145	m <sup>3</sup>	
3	Stones for Apron φ 50 <del>mm</del> cm		7.5	4.0	0.80	24	m <sup>3</sup> (not in the drawing!)
4	Cement Masonry		7.4	2.10	1.40	21.76	□
			6.0	2.10	0.90	11.34	◻
					10.42	m <sup>3</sup>	
5	Nos Gabions		145 m <sup>3</sup> ÷ 2 m <sup>3</sup> =			73	nos

Rate Analysis

Gabion check-dam for Tansen in summer 1979

	Quantities	Rates Rs	Amounts
1. Excavation per m <sup>3</sup> within normal lead & lift			
- boulders up to 15 cm mixed with gravel and sand	1.4 md	6.50	9.10
- extra lead of 50 m for transportation of excavated material 40 %	0.4 md	9.10	<u>3.64</u>
			12.74
2. Stone collection and deposition per m <sup>3</sup>			
- with crowbar, stone transportation from collection site to construction site			11.70
- for 0.5 km distance			39.00
extra charge for collection and transportation of big stones 40 %	0.4 md	50.70	<u>20.28</u>
			70.98
3. Stone filling per m <sup>3</sup>			
- gabions: skilled labour	0.35md	13.00	4.55
unskilled labour	1.4 md	6.50	<u>9.10</u>
			13.65
- aprons, stilling basin: skilled labour	0.5 md	13.00	6.50
unskilled labour	3.0 md	6.50	<u>19.50</u>
			26.00
4. Gabion, supply to site, standard 2x1x1 m 10 cm mesh, 8 gauge wire			
- wire for gabion	30 kg	9.00	270.00
- wire for binding	1 kg	9.00	9.00
- netting skilled labour	¼ md	13.00	3.25
- netting unskilled labour	4 md	6.50	26.00
- transport Bhairawa to site incl. loading and unloading	31 kg	0.15	<u>4.65</u>
			312.90

5. Cement masonry in<sub>3</sub> check-dam in mortar 1:3, per m<sup>3</sup>

- cement 180 kg/m<sup>3</sup>
- sand
- skilled labour
- unskilled labour

Quantities	Pates	Amounts
3.6 Bgs	87.50	315.00
0.36 m <sup>3</sup>	105.00	37.80
1 md	13.00	13.00
2 md	6.50	<u>13.00</u>
		378.80

H. G NEPAL  
 Ministry of Forests  
 Department of soil and Water Conservation

Abstract of Costs  
 Sheet No ... 7 ...

Name of Project :- **Manual**  
 Title :- **Gabion Check-Dam, Example**

Place :-  
 Yr ... 1979 ...

S.N.	Description	Quantity	Unit	Rate	Rs	Paise	Remarks
1	Excavation	69	m <sup>3</sup>	12.74	879	06	
2	Stone Collection	179	m <sup>3</sup>	70.98	12705	42	
3	Stone filling						
	- gabions	145	m <sup>3</sup>	13.65	1979	25	
	- apron	24	m <sup>3</sup>	26.00	624	00	
4	Gabion	73	nos	312.90	22841	70	
5	Cement Masonry	10.5	m <sup>3</sup>	378.80	3977	40	
					43006	83	
	Overhead	20%			8601	37	
	<b>Total</b>				<u>51,608</u>	<u>20</u>	
	<b>for 1 check dam</b>						
					(US \$	4336.-)	